



RUBBLECRUSHER

A McLanahan Company

OPERATION & MAINTENANCE MANUAL

Original Instructions

Subject To Change Without Prior Notice



RC-S48

Table of Content

1	Introduction	1-2
1.1	Purpose Of This Handbook.....	1-2
1.2	Confidential Proprietary Information	1-2
1.3	Declaration of Conformity	1-3
1.4	Important Safety Notice.....	1-4
	(1) EC Conformity	1-4
	(2) Noise Level - Hearing Hazard.....	1-4
	(3) Dust Generation.....	1-4
1.5	Intended Use.....	1-5
1.6	Designated Use	1-5
1.7	California Proposition 65 Warning	1-6
1.8	Feedback.....	1-6
1.9	Compliance.....	1-6
1.10	Manufacturer	1-6
2	Safety Information	2-3
2.1	Safety Introduction	2-3
	(1) Safety Symbol.....	2-3
2.2	Hazard Classification.....	2-4
2.3	General Safety Information	2-5
	(1) General Information	2-5
	(2) Good Common Sense and Safe Practices	2-5
	(3) Site Equipment Personnel	2-5
	(4) Qualification of Personnel - Basic Responsibilities.....	2-5
	(5) Machine Management	2-6
	(6) Equipment Is Designed With Personal Safety In Mind	2-6
	(7) Site Environment	2-6
	(8) Personal Protection - Wear Appropriate Clothing	2-6
	(9) Safe Operation.....	2-7
	(10) Nip & Crush Points	2-7
	(11) Maneuvering The Machine	2-7
	(12) Lock & Tag Out	2-7
	(13) Maintenance	2-7
	(14) Replacement Parts	2-8
	(15) High Pressure Lines And Fluids.....	2-8
	(16) Hydraulic Safety.....	2-8
	(17) Working With Batteries Safely	2-9
	(18) Hazardous Substances.....	2-9
	(19) Handle Chemicals Safely.....	2-9
	(20) Disposing Of Waste Products Safely	2-9
	(21) Material/Debris Build Up Fire Hazard	2-9
	(22) Working At Heights	2-10
	(23) Electrical Energy	2-10
	(24) Welding	2-11

(25) Gas, Dust, Steam, Smoke	2-11
(a) Dust From Crushed Material	2-12
(26) Modifications	2-12
(27) Fire Safety	2-12
(28) Machine Hazard Decals	2-12
(29) Serial Plate	2-13
2.4 Machine Hazard Decals & Locations	2-14
(1) Machine Hazard Decals	2-14
(2) Hazard Decals Locations	2-18
2.5 Safety Prior & During Setup	2-19
2.6 Safety Prior & During Operation	2-20
(1) Exclusion Zone During Operation	2-21
(2) Noise Level During Operation	2-22
2.7 Safety Prior & During Maintenance	2-23
2.8 Lock & Tag Out Procedure	2-25
(1) Implement The Lock & Tag Out	2-25
(2) Remove The Lock & Tag Out	2-26
2.9 Emergency Stop Buttons	2-27
(1) Emergency Stop Button Locations	2-28
(2) Emergency Shut-Down Procedure	2-29
(3) Restarting After Emergency Shut-Down	2-29
3 Technical Data	3-2
3.1 Component Identification	3-2
(1) Component Description	3-3
3.2 General Information	3-4
(1) Machine	3-4
(a) Screen Box	3-4
(b) Oversize Conveyor	3-4
(c) Middle Grade Conveyor	3-4
(d) Collection Conveyor	3-4
(e) Fines Grade Conveyor	3-5
(f) Tracks	3-5
3.3 Applications	3-6
3.4 Machine Dimensions	3-7
(1) Transport Dimensions	3-7
(2) Working Dimensions	3-8
4 Product Familiarisation	4-2
4.1 Machine Orientation	4-2
4.2 Control Panel Familiarisation	4-3
(1) Control Panel Functions	4-3
4.3 Control Panel Menu Screens	4-4
(1) Menu Screen Common Icons	4-4
(a) Radio Remote Control Icon Status	4-4
(b) Service Icon Status	4-5
(2) Splash Screen	4-5

Contents

(3)	Home Screen.....	4-6
(a)	Warning Lamps	4-6
(b)	Engine Information	4-7
(4)	Machine Operating Screen	4-8
(5)	Menu Select Screen	4-9
(a)	Machine Information Screen	4-10
(b)	Machine Fault Log Screen	4-11
(c)	Settings Screen	4-12
(6)	Tracking Screen.....	4-13
(7)	Machine Pop-Up Screens.....	4-14
(a)	Machine Fault Pop-Up Screen	4-14
4.4	Umbilical & Radio Remote Handsets	4-15
(1)	Umbilical Handset.....	4-15
(2)	Radio Remote Handset	4-16
4.5	Hydraulic Controls	4-17
5	Engine Start-Up.....	5-2
5.1	Prior To Starting The Engine.....	5-2
5.2	Starting The Engine	5-3
6	Maneuvering The Machine	6-2
6.1	Safe Maneuvering Instructions.....	6-2
(1)	Checks Prior To Maneuvering.....	6-2
(2)	Operating Precautions	6-4
(3)	Crawler Track Working Conditions.....	6-5
6.2	Maneuvering With Umbilical Handset.....	6-6
(1)	Umbilical Handset - Direction Of Travel.....	6-9
6.3	Maneuvering With Radio Remote Handset.....	6-10
(1)	Radio Remote Handset - Direction Of Travel	6-13
7	Machine Setup.....	7-2
7.1	Safety Prior To & During Setup.....	7-3
(1)	Prior To Setup	7-3
(2)	During Setup.....	7-3
(3)	Setup Measures After Long Term Standstill.....	7-4
(4)	Setup Sequence	7-4
7.2	Setting Up The Machine	7-5
(1)	Task 1 - Remove Machine From The Transporter	7-5
(2)	Task 2 - Position The Machine.....	7-6
(3)	Task 3 - Activate Hydraulic System.....	7-7
(4)	Task 4 - Unfold The Oversize Conveyor	7-8
(5)	Task 5 - Unfold The Mid-Size Conveyor	7-10
(6)	Task 6 - Unfold The Fines-Size Conveyor	7-12
8	Machine Operation.....	8-2
8.1	Checks Prior To Operating.....	8-3
8.2	Putting The Machine Into Operation	8-4
(1)	Auto Run Mode.....	8-4
(a)	Control Panel.....	8-4

(b)	Remote Control Operation	8-6
(2)	Manual Mode	8-9
(a)	Control Panel.....	8-9
(b)	Remote Control Operation	8-11
9	Machine Shut Down.....	9-2
9.1	Shutting Down The Machine.....	9-3
(1)	Auto Mode	9-3
(a)	Control Panel.....	9-3
(b)	Radio Remote	9-5
(2)	Manual Mode	9-7
(a)	Control Panel.....	9-7
(b)	Radio Remote	9-9
9.2	Emergency Shut Down.....	9-11
(1)	Restart After Emergency Stop	9-12
10	Machine Transport.....	10-2
10.1	Prior To Transport.....	10-3
(1)	Transport Sequence	10-3
10.2	Placing The Machine Into Transport Position	10-4
(1)	Task 1 -Activate Hydraulic System	10-4
(2)	Task 2 - Fold Oversize Conveyor.....	10-5
(3)	Task 3 - Fold Mid-Size Conveyor.....	10-7
(4)	Task 4 - Fold Fines Size Conveyor	10-9
(5)	Task 5 - Load Machine The On Transporter	10-11
(6)	Machine Tie Down Points	10-12
11	Maintenance	11-4
11.1	Safety Before and During Maintenance	11-4
11.2	Maintenance Schedules	11-5
(1)	Initial Checks (Running In).....	11-5
(2)	Prior Machine Start	11-5
(3)	Daily & Weekly Maintenance	11-6
(4)	Routine Maintenance.....	11-8
(a)	First 100 Hour Service Schedule.....	11-8
(b)	First 250 Hour Service Schedule.....	11-8
(c)	250 Hour Service Schedule.....	11-8
(d)	500 Hour Service Schedule.....	11-8
(e)	1000 Hour Service Schedule.....	11-9
(f)	2000 Hour Service Schedule.....	11-9
(5)	Engine Maintenance	11-10
(a)	When Required	11-10
(b)	Daily/10 Hour Service Schedule.....	11-10
(c)	Every 50 Service Hours or Weekly.....	11-10
(d)	Every 250 Service Hours.....	11-10
(e)	Every 250 Service Hours or 6 Months.....	11-10
(f)	Every 250 Service Hours or 1 Year	11-10
(g)	Initial 500 Hours	11-11

	(h) Every 500 Service Hours.....	11-11
	(i) Every 500 Service Hours or 1 Year	11-11
	(j) Every 1000 Service Hours.....	11-11
	(k) Every 1000 Hours Service Schedule.....	11-11
	(l) Every 2000 Service Hours.....	11-11
	(m) Every Year	11-11
	(n) Every 3000 Service Hours.....	11-12
	(o) Every 3000 Service Hours or 2 Years	11-12
	(p) Every 4000 Service Hours.....	11-12
	(q) Every 6000 Service Hours or 3 Years	11-12
	(r) Every 12 000 Service Hours or 6 Years	11-12
	(s) Overhaul.....	11-12
	(t) Commissioning.....	11-12
	(6) Lubrication Schedule	11-13
11.3	Lubricants & Fluids.....	11-14
	(1) Recommended Lubricants & Fluids.....	11-14
	(a) Engine Oil.....	11-14
	(b) Engine Coolant.....	11-14
	(c) Diesel Fuel	11-14
	(d) Crawler Track Gearboxes.....	11-14
	(e) Crawler Track Tensioning Grease	11-14
	(f) Conveyor Bearing Grease.....	11-14
	(g) Hydraulic Oil	11-15
	(h) Vibrating Screen Bearing Grease.....	11-15
	(2) Lubricant & Fluid Quantities.....	11-15
11.4	Crawler Track Maintenance.....	11-16
	(1) Correct Maintenance Procedure.....	11-16
	(2) Checking Track Tension.....	11-17
	(3) Adjustment Of Track Tension.....	11-18
	(a) Tightening the Track	11-18
	(b) Slackening the Track	11-19
	(4) Changing Track Belt	11-20
	(a) Removing the Track Belt	11-20
	(b) Refitting the Belt	11-22
	(5) Track Gearbox Maintenance.....	11-23
	(a) Oil Fitting & Draining	11-23
11.5	Engine Maintenance	11-24
	(1) Engine Oil Level - Check	11-24
	(2) Engine Oil And Filter - Change	11-26
	(a) Drain The Engine Oil	11-26
	(b) Replace The Oil Filter.....	11-27
	(c) Fill the Engine Crankcase	11-28
	(3) Servicing the Air Cleaner Element.....	11-29
	(a) Engine Air Cleaner Service Indicator - Inspect.....	11-30
	(b) Test The Service Indicator.....	11-30
	(4) Fuel System Maintenance	11-31

(a)	Fuel System Primary Filter/ Water Separator - Drain	11-31
(b)	Fuel System Primary Filter (Water Separator) Element - Replace.....	11-33
(c)	Fuel System Secondary Filter - Replace.....	11-34
(d)	Fuel System - Prime.....	11-35
(e)	Refuelling	11-37
(5)	Cooling System Coolant (DEAC) - Change	11-38
(a)	Cooling System Coolant Level - Check.....	11-38
(b)	Drain.....	11-39
(c)	Flush.....	11-39
(d)	Cooling Systems With Heavy Deposits Or Plugging	11-40
(e)	Fill.....	11-40
11.6	Conveyor Maintenance.....	11-42
(1)	All Conveyor Belts	11-42
(a)	Conveyor Daily Checks	11-42
(b)	Inspect & Clean	11-43
(2)	Oversize Conveyor	11-44
(a)	Belt Tensioning	11-44
(b)	Belt Alignment	11-45
(3)	Collection Conveyor.....	11-46
(a)	Belt Tensioning	11-46
(b)	Belt Alignment	11-47
(4)	Mid & Fines Size Conveyor	11-48
(a)	Belt Tensioning	11-48
(b)	Belt Alignment	11-49
11.7	Vibrating Screen Box Maintenance.....	11-50
(1)	Changing Screen Meshes	11-50
11.8	Hydraulic Oil Tank Maintenance.....	11-53
(1)	Hydraulic Tank Components.....	11-53
(2)	Hydraulic Diagram	11-54
(3)	Hydraulic Oil Level.....	11-55
(4)	Hydraulic Oil & Suction Stainers Replacement.....	11-56
(5)	Return Line Filter Replacement.....	11-58
11.9	Electrical Maintenance	11-59
(1)	Battery Checks	11-59
(2)	Battery Removal	11-59
(3)	Battery Installation	11-60
11.10	Hydraulic Cylinders - Care Of Chrome Recommendation	11-61
11.11	Recommended Bolt Torque Settings	11-62
(1)	Maximum Bolt Loads And Torque Values (UNC Threads).....	11-62
(2)	Maximum Bolt Loads And Torque Values (UNF Threads)	11-62
(3)	Maximum Bolt Loads And Torque Values (Metric Coarse Threads)	11-63
(4)	A Guide To Torque Values.....	11-64
12	Troubleshooting.....	12-2
12.1	General Trouble Shooting	12-2
12.2	Electrical Trouble Shooting.....	12-5
12.3	Hydraulic Trouble Shooting	12-6

Contents

12.4	Crawler Track Troubleshooting	12-7
	(1) Track Tension.....	12-7
	(2) Loss Of Drive	12-8
12.5	Radio Remote Troubleshooting.....	12-9
12.6	Conveyor Belt Troubleshooting.....	12-10
13	Decommissioning The Machine	13-2
14	Warranty.....	14-2
14.1	Warranty Period and Machine Registration.....	14-2
	(1) Warranty Period.....	14-2
	(2) Machine Registration	14-2
	(3) Engines Shall Be Registered With Local Dealers.....	14-2
	(4) Parts Shall Be Recommended.....	14-2
14.2	Rubblecrusher’s Responsibilities	14-3
14.3	Rubblecrusher’s Non Responsibility	14-3
14.4	Rubblecrusher Limited Product Warranties And Conditions	14-4
15	Revision Log	15-1

Table of Content

1	Introduction	1-2
1.1	Purpose Of This Handbook.....	1-2
1.2	Confidential Proprietary Information	1-2
1.3	Declaration of Conformity	1-3
1.4	Important Safety Notice.....	1-4
	(1) EC Conformity	1-4
	(2) Noise Level - Hearing Hazard.....	1-4
	(3) Dust Generation.....	1-4
1.5	Intended Use.....	1-5
1.6	Designated Use	1-5
1.7	California Proposition 65 Warning	1-6
1.8	Feedback.....	1-6
1.9	Compliance.....	1-6
1.10	Manufacturer	1-6

1 Introduction

Thank you for choosing us. All our products are engineered equipment incorporating diesel, hydraulic, electrical and mechanical components of the highest quality.

In the interest of continuous plant reliability, it is essential that the machine is maintained with meticulous care and attention. This operation and maintenance handbook has been produced to assist the user to obtain the maximum output from the machine and to trace and remedy faults, should they arise. Failure to do so could result in personal injury or equipment damage.

This handbook is an important part of your purchase as it will familiarise you with the machine and explain the numerous features and options that have been designed and apply to this unit. Keep a copy of this handbook with the machine at all times.

Follow all applicable safety regulations and recommendations in this handbook as appropriate to your machine. Also, take into account all on-site conditions and situations prevailing at the time.

Where the supply of this machine is intended for incorporation into a complete processing machine or system that has not been designed and/or constructed by us, then we will NOT be responsible for addressing environmental issues and/or health and safety protection measures for the machine installation as a whole and will bear NO responsibility for ensuring compliance with any regulations and/or statutory requirements that may apply unless specifically included in the contract of sale.

1.1 Purpose Of This Handbook

The purpose of this Operator's handbook is to provide the operator with information on how to handle and operate this equipment. It is important to:

- Keep the handbook for the lifetime of the equipment.
- Pass the handbook on to any subsequent holder or user of the equipment.

USER'S, OPERATOR'S, AND OWNER'S CONTRIBUTION TO SAFE USE OF EQUIPMENT



We appreciate your choice of our product for your application. Our number one priority is the utmost of user safety which is best achieved by joint efforts.

We feel that you can make a major contribution to safety if you as the equipment users and operators :

- Comply with OSHA, MSHA, Federal, State, and Local Regulations.
- Read, understand, and follow the instructions in this and other handbooks supplied with this product.
- Use Good, Safe Work Practices in a common sense way.
- Only have trained operators — directed by informed and knowledgeable supervision operating this product.

1.2 Confidential Proprietary Information

This document is property of RUBBLECRUSHER Limited and shall not be used or copied except as expressly authorized. Information contained in this document is a trade secret and any use of the information, except by its intended receiver, is strictly prohibited and misappropriation of the information shall make the non intended receiver liable for any and all damages suffered as a result by the Rubblecrusher Limited.

1.3 Declaration of Conformity

RUBBLECRUSHER HQ
Little Alton Farm, The Altons, Ravenstone, Coalville, LE672AA
Tel: +44 01530 563600
E-mail: info@rubblecrusher.com

RUBBLECRUSHER hereby declares that the following machinery manufactured by us complies with the relevant essential Health and Safety requirements of:

- The Supply of Machinery (Safety) Regulations 1992- SI 1992 No. 3073.
- The Supply of Machinery (Safety) (Amendment) Regulations 1994-SI 1994 No.2063.
- The Supply of Machinery (Safety) (Amendment) regulations 2005- SI 2005 No. 831.
- The Machinery Directive 2006/42/EC.

The machinery also complies with the:

- Electrical Equipment (Safety) Regulations 1994- SI 1994 No. 3260.
- The Low Voltage Directive 2014/35/EU).
- The Electromagnetic Compatibility (Amendment) Regulations 1994-SI 1994 No. 3080.
- The EMC Directive 2004/108/EC.

The following harmonised standards have been used-

- BS EN ISO 14121 - 1:2007 Safety of Machinery- Risk Assessment- Part 1: Principles.

Description of Machinery:	RC-S48 Mobile Screen
Serial No:	RC-S48-0020
Year of Manufacture:	2025
Name:	Matthew Brough
Signed:	
Position:	Technical Director
Date:	16/03/2026

Being the responsible person appointed by the company

1.4 Important Safety Notice

The operator shall read and understand the information contained in this handbook prior to operating the machine.

The safety symbol (Fig: 1.1) is used for all safety warnings. Please follow them carefully. The attention of operating personnel should be drawn to these safety instructions. General safety and accident prevention regulations laid down by law must also be observed.



Fig: 1.1 - Safety Symbol

Please contact your dealer or the factory should you have questions regarding specific applications or if you require additional information or advice.

See also the separate Operation and Maintenance Handbook provided for the diesel engine and track frames fitted to your plant and in particular read and observe the instructions within the Safety Section of the handbooks.

(1) EC Conformity

	<p>This product is in conformity with the provisions of the EC Machinery Directive 2006/42/EC and the Electromagnetic Compatibility Directive 2004/108/EC, together with appropriate EN Harmonised Standards and National BS Standards and Specifications.</p>
--	--

(2) Noise Level - Hearing Hazard

	<p>May cause loss or degradation of hearing over a period of time. Wear proper hearing personal protective equipment.</p>
--	---

(3) Dust Generation

	<p>INHALATION HAZARD Death, serious injury or delayed lung disease may result from breathing dusts that are generated when certain hazardous materials are crushed, screened or conveyed with this equipment. When dusts are generated by the operation of this equipment, use approved respiratory protection, as required by Federal, State and Local safety and health regulations.</p>
--	---

1.5 Intended Use

OTHER THAN RECOMMENDED- APPLICATIONS ARE PROHIBITED AND MAY VOID THE WARRANTIES PROVIDED BY THE MANUFACTURER. IF QUESTIONS ARISE CONCERNING THE PROPRIETY OF OPERATION OF THE PRODUCT IN A PARTICULAR CONTEMPLATED APPLICATION, CONTACT THE MANUFACTURER.

Federal, National, State, Local laws and safety regulations (including those concerning safe operation of heavy equipment) must be complied with at all times in order to prevent possible danger to personnel or property from accidents or harmful exposure.

Follow outlined instructions on how to maintain your plant correctly. Failure to do so could result in personal injury or equipment damage.

RUBBLECRUSHER will not accept any liability for damage to equipment or injury to personnel caused by unauthorized or improper use or modification of this equipment.

This machine has been designed for use in material processing in the following applications:

- Crushing
- Screening
- Recycling

Compliance with the operating instructions and performing routine maintenance work in adherence to maintenance intervals are all characteristics of correct use of the equipment. Use of the of the machine in any other way is prohibited and contradictory to its intended use.

1.6 Designated Use

This machine has been built for the application outlined in intended use ("Intended Use" on page 1-5). Use of the machine that exceeds the intended use is considered to be conflicting to the machines intended purpose. The manufacturer will not assume responsibility for any damage resulting from misuse.

Using the machine in accordance with the intended use also implies compliance with the conditions laid down by the manufacturer for operation, maintenance and servicing.

This machine shall only be operated by personnel trained in its use and the hazards involved.

The machine has been designed as an independent mobile vibrating screen with three stockpile conveyors for separating materials into various sizes.

Material is fed by the operator directly into vibrating screen by loading shovel or a conveyor.

The vibrating screen then divides the material into three separate sizes. The top deck of the vibrating screen (oversize) material is transferred onto the oversize conveyor. The second deck of the screen transfers the middle grade material onto the middle grade conveyor. The remainder of the material falls through to the collection conveyor where it is then discharged onto the fines conveyor.

The screen has interchangeable meshes with different apertures for different sizes of material.

The materials that can be screened are as follows;

- Crushed Stone
- Sand and Gravel
- Iron Ore
- Construction & Demolition
- Coal
- Grain
- Refuse
- Top soil

- Wood bark
- Wood chips
- Scalping

Please contact us if you would like to process a material that is not listed above.

1.7 California Proposition 65 Warning

This machine can expose personnel to chemicals including lead and lead compounds (as contained in batteries and related components), which are known to the State of California to cause cancer and birth defects or other reproductive harm. For further information, go to www.P65Warnings.ca.gov.

Breathing diesel engine exhaust exposes you to chemicals known to the State of California to cause cancer and birth defects or other reproductive harm.

- Always use the engine in a well-ventilated area.
- In an enclosed environment, ensure to vent the exhaust to the outside.
- Do not modify or tamper with the exhaust system.
- Only idle the engine when necessary.

1.8 Feedback

If you have comments on this operator's handbook or problems connected to the documentation provided, contact us at: info@rubblecrusher.com.

1.9 Compliance

The instructions in this document are in accordance with the design and construction of the equipment at the time it was delivered from the manufacturing plant.

1.10 Manufacturer

This equipment has been manufactured by:

RUBBLECRUSHER

Little Alton Farm

The Altons

Ravenstone

Coalville

LE672AA

Table of Content

2	Safety Information	2-3
2.1	Safety Introduction	2-3
	(1) Safety Symbol.....	2-3
2.2	Hazard Classification.....	2-4
2.3	General Safety Information	2-5
	(1) General Information	2-5
	(2) Good Common Sense and Safe Practices	2-5
	(3) Site Equipment Personnel	2-5
	(4) Qualification of Personnel - Basic Responsibilities	2-5
	(5) Machine Management	2-6
	(6) Equipment Is Designed With Personal Safety In Mind	2-6
	(7) Site Environment	2-6
	(8) Personal Protection - Wear Appropriate Clothing	2-6
	(9) Safe Operation.....	2-7
	(10) Nip & Crush Points	2-7
	(11) Maneuvering The Machine	2-7
	(12) Lock & Tag Out	2-7
	(13) Maintenance	2-7
	(14) Replacement Parts	2-8
	(15) High Pressure Lines And Fluids.....	2-8
	(16) Hydraulic Safety.....	2-8
	(17) Working With Batteries Safely	2-9
	(18) Hazardous Substances.....	2-9
	(19) Handle Chemicals Safely.....	2-9
	(20) Disposing Of Waste Products Safely	2-9
	(21) Material/Debris Build Up Fire Hazard	2-9
	(22) Working At Heights	2-10
	(23) Electrical Energy	2-10
	(24) Welding.....	2-11
	(25) Gas, Dust, Steam, Smoke	2-11
	(a) Dust From Crushed Material	2-12
	(26) Modifications.....	2-12
	(27) Fire Safety	2-12
	(28) Machine Hazard Decals.....	2-12
	(29) Serial Plate	2-13
2.4	Machine Hazard Decals & Locations.....	2-14
	(1) Machine Hazard Decals.....	2-14
	(2) Hazard Decals Locations.....	2-18
2.5	Safety Prior & During Setup.....	2-19
2.6	Safety Prior & During Operation.....	2-20
	(1) Exclusion Zone During Operation.....	2-21
	(2) Noise Level During Operation.....	2-22

2.7 Safety Prior & During Maintenance 2-23

2.8 Lock & Tag Out Procedure 2-25

(1) Implement The Lock & Tag Out 2-25

(2) Remove The Lock & Tag Out..... 2-26

2.9 Emergency Stop Buttons 2-27

(1) Emergency Stop Button Locations 2-28

(2) Emergency Shut-Down Procedure 2-29

(3) Restarting After Emergency Shut-Down 2-29

2 Safety Information

2.1 Safety Introduction

The owner of this machine and/or the operator are responsible for the health and safety of all personnel operating, inspecting or performing any maintenance tasks within the vicinity the machine.

The safety section outlined in this handbook in no way replaces any laws or other binding accident prevention and environmental protection regulations.

Any personnel who operate, maintain, or carry out any type of maintenance work on or near the machine are required to be trained in the correct, safe procedures for the work they are going to perform.

The selected personnel shall:

- Be reliable and experienced, with knowledge of the machine (statutory minimum age limits shall also be observed).
- Have read and understood the full content provided within this handbook prior to performing any activities with the machine.
- Be fully aware of the hazards associated with the machine.
- Have received the correct, specific, and adequate training for any particular tasks to be performed.
- Be aware of all operational components on the machine.
- Be aware of the operational and performance limits of the machine.
- Know the location of all safety features on the machine.
- Have read and understood any on-site safety handbooks produced by the site owner.

IMPORTANT: The instructions provided in this handbook have been provided based on ideal site conditions and machine set-up. Not all sites or machine set-ups will be the same, therefore, in the interests of safety the instructions given here should be adapted to suit the conditions and set-up of each particular machine.

Personnel performing any tasks with the machine shall assess all on-site risks and take these into account prior to performing any tasks. All effort shall be made to find and eliminate all on-site risks associated with this machine.

(1) Safety Symbol

The safety symbol (Fig: 2.1) is used for all safety warnings. Please follow them carefully. The attention of operating personnel should be drawn to these safety instructions. General safety and accident prevention regulations laid down by law shall also be observed.



Fig: 2.1 - Safety Symbol

2.2 Hazard Classification

Within this operators and maintenance handbook, safety hazard warnings are indicated with the use of the following hazard classification system. Hazard warnings are in this handbook to alert and prevent the operator or any bystander's from sustaining any potential injuries.

Hazard warnings are presented with the use of a safety alert symbol and the signal words; (DANGER, WARNING, or CAUTION). Below the hazard warning a description of the hazard is stated. Each hazard warning has a different severity and shall never be ignored. Ignoring safety hazard warnings will result in serious injury or death.



DANGER

DANGER - indicates a hazardous situation that, if not avoided, will result in death or serious injury.



WARNING

WARNING - indicates a hazardous situation that, if not avoided, could result in death or serious injury.



CAUTION

CAUTION - indicates a hazardous situation that, if not avoided, could result in minor or moderate injury.

The operators handbook will also contain the use of the signal words; NOTICE and SAFETY INSTRUCTIONS.

The signal word 'NOTICE' is used to alert the operator of any potential issues caused by misuse of the machine.

NOTICE

NOTICE - addresses practices not related to physical injury, but is still considered important such as security, hygiene, housekeeping, equipment etc.

The signal words 'SAFETY INSTRUCTIONS' will be used to alert the operator of any safety-related instructions, procedures, or suggestions.

SAFETY INSTRUCTION

Green and white signs indicate specific safety-related instructions, procedures, or suggestions.

2.3 General Safety Information

(1) General Information

We have made every practicable attempt to eliminate and minimise the risk of injury which could be caused during the normal operation, installation and maintenance of this machine. When using the equipment the following safety practices shall be adhered to help minimise the identified risks:

- Turn off all power prior to working on the machine.
- Keep areas around machine clear of obstructions and debris.
- Report all unsafe conditions and practices to your supervisor.
- Do not walk, sit or climb on machine without turning off all power supplies.
- Do not start the machine without both an audible or visual “all clear”.
- Only authorised personnel should operate the machine.
- Do not operate the machine with guards or protective equipment removed.
- Do not remove jammed material with machine operating or powered on.
- Do not stand within a 15m (50 ft) radius of the machine when it is in operation.
- Keep loose items, including, hair, fingers, clothing, gloves, neck ties and jewelry clear of moving parts.
- Know design limits. Do not overload machine.
- Know location and function of emergency stops.
- Only authorised maintenance personnel to service the equipment.

(2) Good Common Sense and Safe Practices

This machine offer's many safety features, some standard, while others are optional and specified by the user based on conditions under which the equipment will be operated. The machine shall be operated at it's design capacity and speed. The area around loading and unloading points shall be kept clear of obstructions which could endanger personnel. Under no circumstances shall the safety characteristics of this machine be altered. Alterations will endanger personnel.

(3) Site Equipment Personnel

Only authorized or trained personnel are permitted to work on this machine. Authorized, means that a person has undergone a theoretical and/or a practical test of knowledge. They are therefore deemed to have the knowledge and competence to perform the tasks assigned to the appropriate role. Trained, means that the person in question has been given practical instruction by an authorized person on how the various tasks are to be carried out.

All expected work tasks on this machine have been defined as belonging to one of the following three categories. Work roles are based on different competence profiles.

The three work roles are:

- Installation
- Operation
- Maintenance

The technical documentation within this handbook only provides information for this machine, it does not provide information for work tasks associated with other equipment or routines at the site.

(4) Qualification of Personnel - Basic Responsibilities

Only reliable, authorised and trained personnel shall execute any work on and/or with the machine. Statutory minimum age limits shall be observed.

(5) Machine Management

It is the responsibility of the plant management to assign responsibility for:

- The production equipment and the work area around the equipment.
- All personnel in the vicinity of the equipment.
- Compliance with national and local safety regulations.
- Checking that all safety devices are fully operational.

All responsibility will be declined for any injury or damage resulting from noncompliance with the instructions in this handbook.

(6) Equipment Is Designed With Personal Safety In Mind

This machine has been designed with the safety of all personnel in mind. Never attempt to change, modify, or bypass any of the safety devices that have been installed by the manufacturer.

Covers and guards are installed around moving parts to prevent accidental injury to operators and other personnel. Do not remove them. Guards removed during maintenance or service shall be re-placed.

Basic safety practices:

- Know where your fellow co-workers are. Always look around and inside this machine prior to starting it.
- Always lock and tag out involved energy sources prior to performing maintenance or adjustments on this equipment.
- Don't limit safety practices. Always think safety and act safely at all times.
- Know your equipment. Understand the machinery, the conditions under which it operates and what it is capable of doing.
- Read all danger, warning, caution, and notice signs.

(7) Site Environment

The environment in which the machine will operate contains inherent risks. The operator shall take the necessary steps to guard against these risks. Avoid these risks by carrying out appropriate risk assessments prior to placing the machine into operation. Ensure appropriate exclusion zone measures are put in place and site personnel safety training awareness has been undertaken.

(8) Personal Protection - Wear Appropriate Clothing

It is strongly recommended that personal protective equipment is always worn when working in the vicinity of the equipment. Be prepared for any existing and potential conditions prior to operating machine. Always wear correctly fitting (EN/ANSI approved) protective clothing. The following protective clothing is recommended; Hard Hat, Safety Glasses, Ear Protection, Close fitting Overalls, Steel Toed Boots, and a High Visibility Vest.

Dress appropriately in every way. Never wear loose clothes, ensure long hair is tied back, clothing should not have coat tails, wearing of jewelry is not recommended, avoid pockets full of tools or any other item that could get caught in moving parts.

Ear defenders of approved design shall be worn at all times when the plant is in operation.

(9) Safe Operation

When operating the machine, the following shall be taken into consideration:

- Use only attachments and accessories approved by the manufacturer of this product.
- If the machine vibrates / operates abnormally, stop the engine and check immediately for the cause. Vibration is generally a warning of trouble.
- Know how to stop the machine and disengage the controls quickly.
- Make any necessary adjustments prior to operating the machine. Never attempt to make any adjustments while the engine is running, unless if recommended in adjustment procedure.
- Take all possible precautions when leaving the machine unattended. Switch off the engine, remove the ignition key, and implement the lock and tag out procedure.

(10) Nip & Crush Points

Rotating conveyor belts, drums & rollers, vibrating screens, and other various moving parts of this machine create potentially serious nip and crush points. It is strictly prohibited for personnel to reach into any part of the machine when it is operating.

- Always switch the machine off and implement the lock and tag out procedure outlined within this handbook when maintenance, repairs or adjustments are required.
- Loose clothing, jewelry and long hair should be tied back or removed to avoid entanglement with the components.
- Guards are installed at high risk nip points on the machine. These guards shall be kept in place at all times.
- It is strictly prohibited to operate the machine with any damaged or missing guards.
- The machine shall only be started when the operator has ensured that the vicinity of the machine is clear of any personnel.
- Roller nip guards shall be set to the maximum 5mm gap setting. Adjust if necessary.

(11) Maneuvering The Machine

Do not track the machine any longer than 10 minutes without a 10 minute cool down period prior to tracking again.

(12) Lock & Tag Out

Employers shall establish and follow a lock and tag out procedure and train employees in that procedure before any employee can operate, service or maintain any piece of power equipment. Employers are required to make periodic inspections to see that their lock and tag out procedures are being followed. Employees are responsible for seeing that equipment is locked and tagged out in accordance with the employer's policy and the instructions outlined within this handbook.

(13) Maintenance

Maintenance or repairs shall be done at a time the machine can be taken out of service, properly locked out and tagged. In no circumstances shall operating equipment be serviced on. Only visual inspection can be done during operation and the care taken to be at a safe distance.

Stop all moving machinery during periods of lubrication, maintenance, or adjustment.

Maintenance functions are to be performed while the machine is switched off. Never work on a machine while it is operating, unless maintenance procedure requires operation.

Only trained personnel should track a conveyor belt which shall be done while machine is in operation. Do not attempt to align conveyor belts with material on them.

Never power wash the control panel or emergency stops.

Maintain all warning signs in a legible condition and obey all warnings.

(14) Replacement Parts

When replacement parts are required, use only parts specified by the machine manufacturer.

(15) High Pressure Lines And Fluids

Escaping fluid under pressure can penetrate the skin causing serious injury. Avoid the hazard by relieving pressure prior to disconnecting hydraulic or other lines. Tighten all connections prior to applying pressure.

If an accident occurs, see a doctor immediately. Any fluid injected into the skin shall be surgically removed within a few hours or gangrene may result. Doctors unfamiliar with this type of injury should reference a knowledgeable medical source.

Hydraulic hoses and lines can fail due to physical damage, kinks, age, and exposure. Check hoses and lines regularly. Replace damaged hydraulic hoses and lines.

Hydraulic fluid connections can loosen due to physical damage and vibration. Check connections regularly. Tighten loose connections.

(16) Hydraulic Safety

- Always practice cleanliness servicing hydraulic components.
- Only personnel certified in hydraulics are permitted to perform operations on the hydraulic system.
- Attempts to perform maintenance or repairs to the machine's hydraulic system, without proper qualifications and/or supervision, can result in serious personal injuries or death. Always relieve pressure from the hydraulic system prior to carrying out any kind of maintenance or adjustment.
- Pressurized oil is dangerous if released incorrectly. Relieve all pressure prior to carrying out maintenance or repair work on the hydraulic system.
- Inspect all hoses, screwed connections and lines for leaks or other damage.
- Repair any leaking or damaged hoses, lines or connections immediately.
- Bleed and de-pressurize the hydraulic lines prior to attempting maintenance or repairs to the machine. Failure to de-pressurize the hydraulic lines can result in serious personal injuries or death.
- After cleaning, examine all lubricant, fuel and hydraulic fluid lines for leaks, loose connections, chafe marks and damage. Any defects found shall be rectified without delay.
- Hydraulic and compressed air lines shall be fitted and laid properly. Ensure that no connections are interchanged. The fittings, lengths and quality of the hoses shall comply with the technical requirements.
- Hydraulic fluid under pressure can penetrate the skin causing serious injury. Always use a piece of cardboard to check for leaks. Do not use your hand. If fluid is injected under the skin, it shall be surgically removed or gangrene will result. Get medical help immediately.
- Hydraulic oil can get very hot in operation. Allow the oil to cool prior to working on the hydraulic system.
- Never touch or alter the hydraulic system when the machine is in operation. The hydraulic system may suddenly change position. Always keep body parts away from the hydraulic system while unit is in operation.

(17) Working With Batteries Safely

- Disconnect battery leads and stow away in a suitable position to prevent accidental start-up when performing maintenance or servicing tasks.
- Battery electrolyte contains acid and can cause serious injuries. Avoid contact with skin and eyes. Always use gloves and protective glasses when working with electrolyte.
- Batteries give off flammable fumes which can explode. Ensure that there is proper ventilation when working with batteries.
- Avoid the formation of sparks and naked lights in the vicinity of the batteries. Do not smoke when working in this area.

(18) Hazardous Substances

- Ensure that correct procedures are formulated to safely handle hazardous materials by correct labelling, identification, disposal, use and storage.
- All hazardous materials shall be handled strictly in accordance with the manufacturers instructions.
- All regulations applicable shall be observed at all times.

(19) Handle Chemicals Safely

- Open and pour chemicals in a well-ventilated area.
- Reserve all equipment used for the application of chemicals exclusively for that purpose.
- Prohibit all smoking, drinking and eating food in chemical-handling area.
- Dispose of all waste fluids, properly and in accordance with applicable statutes and environmental regulations.
- It is best to wear full cover clothing and always wear protective goggles and rubber gloves to protect yourself while handling chemicals.
- Follow instructions on chemical container labels.

(20) Disposing Of Waste Products Safely

Incorrect disposal of waste can impact human health and the environment. The potential harmful waste created from this machine includes oil, diesel fuel, soot, coolant, filters and batteries.

- Always dispose of waste in a safe and environmentally friendly manner. If unsure of disposal methods for a particular waste product, seek advice from your local government environmental department.
- Use suitable leak proof containers when draining fluids. Do not use food or beverage containers that may mislead someone into drinking from them.
- Never pour drained fluids onto the ground, down a drain or into any water source.
- Ensure that all consumable and replaced parts are disposed of correctly and with the minimum environmental impact.

(21) Material/Debris Build Up Fire Hazard

Prior to machine start-up and shut-down of daily running, ensure machine is clear from debris / material especially around engine bay area.

(22) Working At Heights

Falling from a machine can cause serious injury or even death.

Some maintenance tasks require a person to work on a machine at height where fall hazards are present. In such occasions, it is the responsibility of the machine owner to provide an adequate safe working access.

When safe work platforms have been put in place, it is a requirement for the use of an EN/ANSI safety harness when working above specific heights. Check with your local law and regulations authority for the specific height requirements.

Access ladders and walkways are required to be kept clean and free from debris, material, snow, ice, rags and tools.

Never climb on the machine's components. Access platforms shall only be used by authorized personnel.

If any work or adjustments are to be performed, the machine shall be shut down and locked and tagged out.

(23) Electrical Energy

Only electrical personnel working according to European standard EN 50110 or similar are permitted to perform electrical operations on the machine.

Do not hose down any electrical enclosures or electrical motors.

The electrical equipment of this machine is to be checked and inspected at regular intervals. Defects shall be rectified immediately.

When maintenance and repair work is to be performed, the power supply shall be isolated, locked and tagged out.

Prior to performing any work, ensure that the de-energized parts are checked for presence of power and ground or short circuit them in addition to insulating elements and adjacent live parts.

Use specified current rating original fuses.

Maintain a safe distance from overhead electric lines when working with the machine. Working equipment shall be kept well away from overhead lines. Check out the prescribed safety distances.

Line Voltage	Required Clearance
0-50Kv	10ft (3.0m)
50-200Kv	15ft (4.6m)
200-350Kv	20ft (6.1m)
350-500Kv	25ft (7.5m)
500-750Kv	35ft (10.7m)
750-1000Kv	40ft (12.2m)

If your machine comes into contact with a live wire, have the live wire de-energized and warn others against approaching and touching the machine.

Switch off the machine immediately if any trouble occurs in the electrical system.

Prior to activating the main isolator switch, machines with high voltage electrical equipment shall be suitably earth bonded by a qualified electrician.

Work on the electrical system and equipment of the machine shall be performed by a skilled electrician or by instructed persons under the guidance and supervision of a skilled electrician and in accordance with electrical engineering regulations and rules.

(24) Welding

Do not smoke, allow naked lights or sources of sparks, such as welding equipment near the fuel system. If welding tasks are to be performed on this machine, it is essential that the machine is correctly isolated.

Only welders qualified according to European Standards or similar are permitted to perform welding operations on this machine. If welding an item to the machine, the ground cable shall be attached to the item itself. If a machine component is to be welded, the ground cable shall be attached as near to the welding area as possible.

Disconnect the battery ground cable prior to making adjustments on electrical system or welding on the machine.

Perform welding on the machine only if this has been expressly authorised, as there may be a risk of explosion and fire. Prior to welding, clean the machine and its surroundings from dust and other flammable substances and make sure the premises are adequately ventilated as there may be a risk of explosion.

(25) Gas, Dust, Steam, Smoke

Death, serious injury or delayed lung disease can result from inhaling dust that is produced when certain hazardous materials are screened or conveyed with this machine.

Diesel engine exhaust emissions contain products of combustion which may be harmful to your health.

The machine shall be operated in a well ventilated area. When operating in an enclosed environment, ensure to vent the emissions safely outside.

Do not touch any part of the engine or exhaust system. Allow the engine and exhaust system to fully cool prior to attempting any repair or maintenance tasks.

Do not fill the fuel tank with the engine running, while smoking, or when near open flames.

Do not overfill the tank. Clean up any spilt fuel immediately.

Observe and adhere to the all regulations at the respective site.

Dust on the machine or produced during the work cycle shall be removed by extraction, not blowing. Dust shall be dampened, then placed in a sealed container and labelled, to ensure its safe disposal.

When dust is being produced by the operation of this equipment, the use of approved respiratory protection, is required by Federal, State and Local safety and health regulations.

Only perform welding, flame cutting and grinding work on the machine if this has been approved and authorised. There could be a risk of explosions or fire.

Prior to welding, flame cutting or grinding, clean the machine and its surroundings from dust and other flammable substances. Ensure the work environment is adequately ventilated as there could be a risk of explosion.

Operators shall wear a suitable face mask when exposed to harmful effects of air pollution of any kind.

(a) Dust From Crushed Material

The nature of the crusher will produce an amount of dust. If this becomes excessive, operators may need to use a portable mist canon to suppress the dust. If dust suppression using water is required then the operator must be aware of the risk of legionella. A specific risk assessment should be carried out as required.

Common material to be crushed e.g. bricks and concrete contain Crystalline Silica that can cause serious harm if inhaled. A risk assessment should be carried out depending on the application and the correct Respiratory Protection Equipment selected, if required. Below is a table showing expected crystalline silica content in certain materials:

Approximate Crystalline Silica Content Of Different Materials	
Sandstone	70-90%
Concrete, Mortar	25-70%
Tile	30-45%
Granite	20-45%, typically 30%
Slate	20-40%
Brick	Up to 30%
Limestone	2%
Marble	2%

(26) Modifications

Modifications to this machine are strictly prohibited. Under no circumstances modify or make any additions/conversions that will affect the safety features that are installed.

Safety relevant modifications to the machine will only be permitted with written approval from the manufacturer.

If safety relevant modifications or a change in the behavior of the machine occurs while operating, immediately switch off the engine and implement the lock out and tag out procedure. Report the malfunction to the responsible authority/person.

(27) Fire Safety

If installing fire extinguishers to this machine, caution shall be taken if holes are required to be drilled for the placement of the mounting brackets. Pay particular attention to where hydraulic hoses and electrical looms are positioned, ensure not to damage them. If unsure where of a suitable location, contact the machine manufacturer.

It is the responsibility of the owner to ensure the correct type of fire extinguisher is installed. The fire extinguisher shall be suitable for the following types of combustible materials:

- Ordinary combustibles
- Flammable liquid and gases
- Electrical

Fire extinguishers that are installed shall be checked on a regular bases and replaced when necessary.

(28) Machine Hazard Decals

Safety decals are installed on this machine to warn of danger to persons and of possible equipment damage. These signs shall never be removed, tampered with, painted over, or obscured in any way. If labels are damaged or become unreadable, replacement labels are available from the manufacturer.

The user shall institute a continuing program to ensure all safety signs are legible.

(29) Serial Plate

Information regarding the machine model and serial number is on the serial plate. This plate is located on the machine. The machine serial number and model shall always be referenced in any correspondence with your dealer or manufacturer. A sample of the serial plate can be seen below (Fig: 2.2):

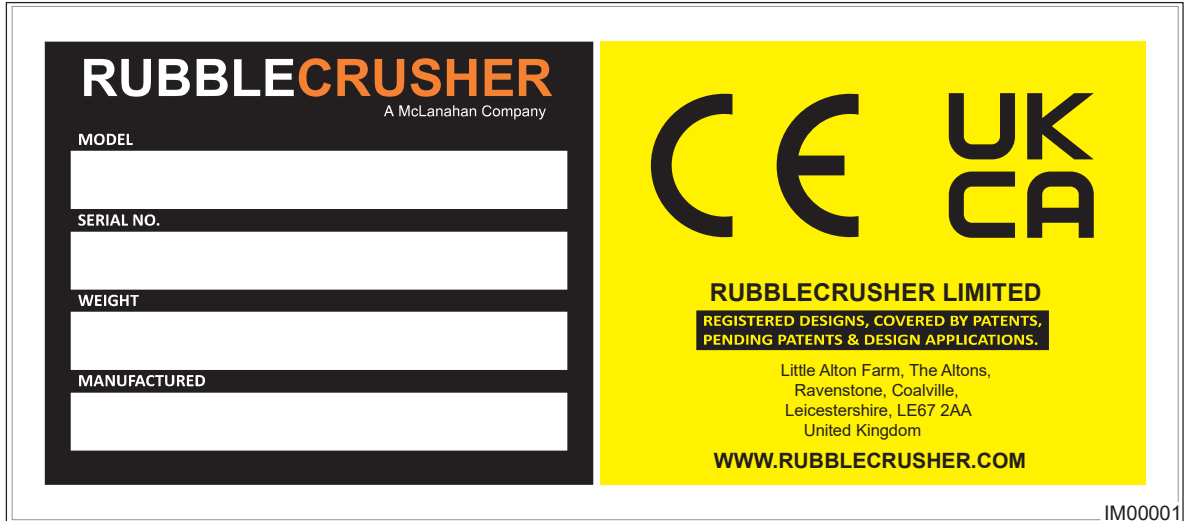

Fig: 2.2 - Serial Plate Sample

2.4 Machine Hazard Decals & Locations

(1) Machine Hazard Decals







NOTICE



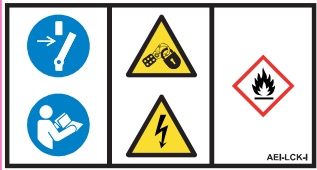

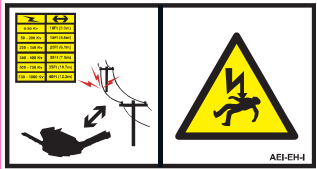
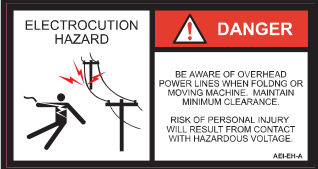
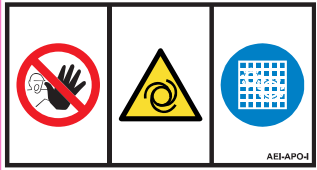

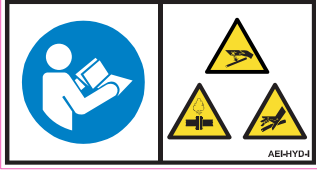





Hazard decals are located around this machine to alert the operator and any other personnel within the vicinity of the machine of potential dangers.

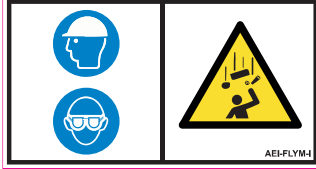

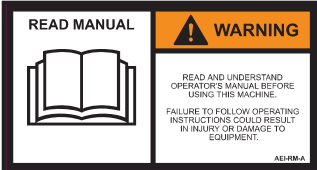

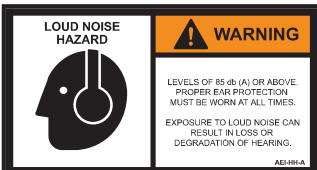

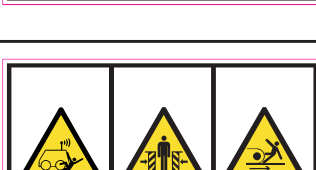

The hazard decals shall be inspected daily and replaced immediately if they become unreadable, lost, or damaged.

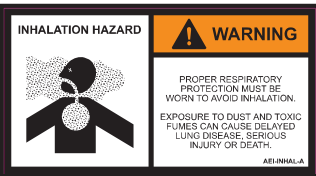

When the machine undergoes repair and components have been removed or replaced on which hazard decals were installed, it is important that new hazard decals are fitted prior to placing the machine back into operation.

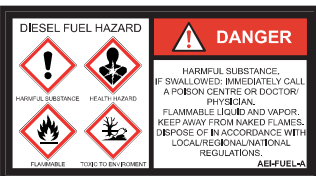
Hazard decals shall be cleaned with the use of mild soap and water. Do not use solvent based cleaners, they will damage the hazard decal material.

NO:	ISO Standard	ANSI Standard	Description
1			DANGER Switch off power, isolate battery and disconnect all energy sources. Lockout prior welding, maintenance or servicing. Serious injury or death risk from hazardous voltage. Ignition hazard from welding.
2			DANGER Be aware of overhead power lines when folding or moving machine. Maintain minimum clearance. Risk of personal injury will result from contact with hazardous voltage.
3			DANGER Equipment may start-up without warning. Unauthorised personnel prohibited. Keep all guards in place during operation.
4			DANGER High-pressure fluid from hose leaks can pierce and penetrate the skin. Relieve pressure prior to maintenance. Use cardboard to check for leaks. Amputation, gangrene, burns or serious injury can result. Seek medical help immediately.

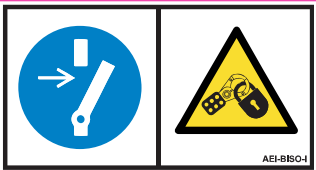
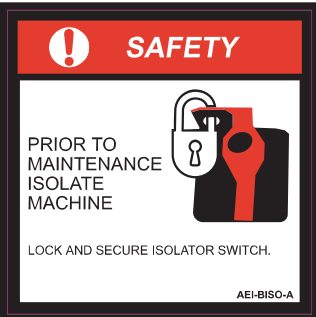
NO:	ISO Standard	ANSI Standard	Description
5			DANGER Burns, blindness, serious injury or death, can result from release of pressurised liquids, corrosive acids and ignition of explosive gases. Keep all open flames and sparks away from battery. Wear protective clothing.
6			DANGER Do not operate equipment with guards or covers removed. Keep clear of moving belt. Risk of personal injury or death.
7			WARNING Beware of flying / falling material. You could be hit in face or body. Wear personal protective clothing and approved safety equipment. You are at risk of fatal injury.
8			WARNING Read and understand operators manual before using this machine. Failure to follow operating instructions could result in injury or damage to equipment.
9			WARNING Levels of 85 db (A) or above. Proper ear protection shall be worn at all times. Exposure to loud noise can result in loss or degradation of hearing.
10			WARNING Keep Clear, Hot Surfaces. Allow to cool prior to servicing. Risk of burns, skin abrasions and serious injury. Wear approved personal protective clothing.
11			WARNING Keep crush zone clear when machine is in operation. Hazard from movement of track frames. Risk of serious injury or death.

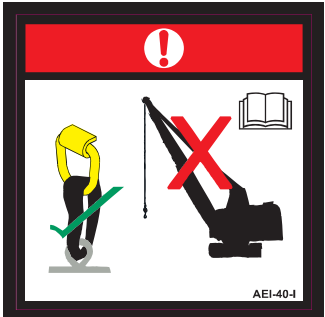
NO:	ISO Standard	ANSI Standard	Description
12			WARNING Falling off machine can cause serious injury or death. Use a suitable platform to service this machine. Use steps or walkways to mount / dismount machine.
13			WARNING Proper respiratory protection shall be worn to avoid inhalation. Exposure to dust and toxic fumes can cause delayed lung disease, serious injury or death.
14			DANGER Harmful substance. If swallowed: immediately call a poison centre or doctor/physician. Flammable liquid and vapor. Keep away from naked flames. Dispose of in accordance with local/regional/national regulations.
15			NOTICE Always wear correct fitting (EN/ANSI approved) protective clothing. Never wear loose clothes. Ensure long hair is tied back. Recommended, but not limited, hard hat, safety glasses, ear protection, overalls, steel toed boots, high visibility vest.
16			SAFETY Emergency Stop. Press to engage, twist to reset.
17			SAFETY Prior to maintenance isolate machine. Lock and secure isolator switch.

NO:	ISO Standard	ANSI Standard	Description
18	 <p>AEI-40-I</p>	 <p>AEI-40-A</p>	<p>SAFETY Tie down point only. Not a machine lifting point.</p>

(2) Hazard Decals Locations

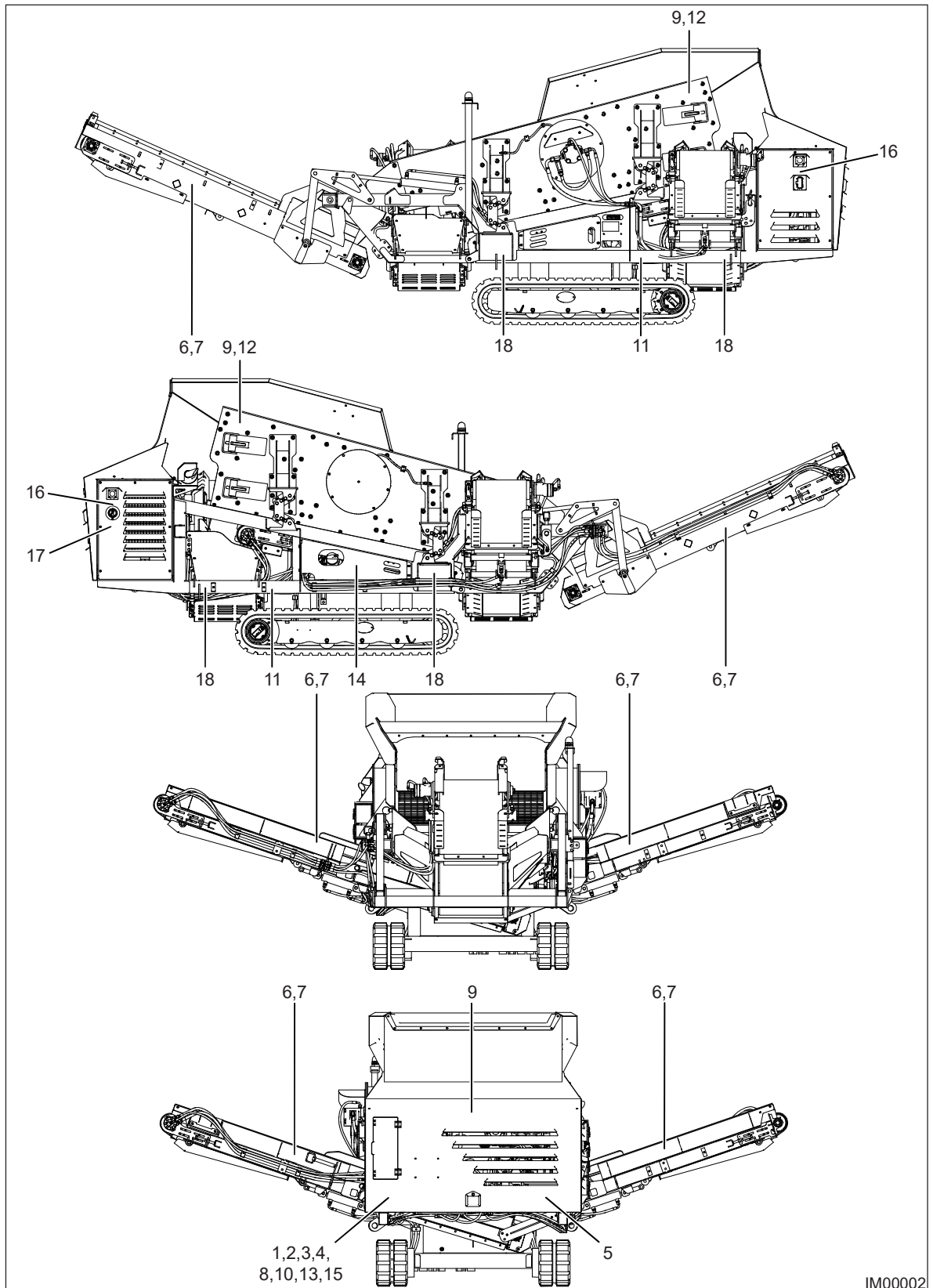

IM00002

Fig: 2.3 - Hazard Decals Locations

2.5 Safety Prior & During Setup

NOTICE

The information provided in this operators handbook in regards to setup, operation, maintenance, and the replacement of machine components has been provided based upon the best possible site conditions and setup of the machine. Not every site or machine setup will be the same. In these circumstances the safety instructions given shall be adapted to suit the conditions and setup of each machine.

Personnel performing work on the machine shall evaluate all the on-site risks and take them into account prior to performing any work. All efforts shall be made to find and eliminate all on-site risks associated with this machine.

Set-up of this machine shall be performed by competent, trained personnel.

- Observe and adhere to all site regulations.
- Setup of the machine requires two people. Never setup a machine alone.
- Ensure that all required personal protective equipment is worn.
- Loose clothing and jewelry shall be removed to avoid entanglement in the machinery.
- Long hair shall be tied back to avoid entanglement in the machinery.
- Ensure the ground where the machine is to be setup is level, suitable to support the machines weight, and has adequate all-round clearance.
- When working on the machine where no work platforms are present, approved work platforms shall be required. Do not climb onto the machine to reach areas that are not accessible from the ground or from platforms. Never use unauthorized or defective platforms to reach inaccessible areas of the machine. When working at height, check with your local law and regulations authority for the specific height requirements.
- Never work beneath unsupported equipment.
- Only use lifting equipment that is in good working order and has been adequately tested. The lifting equipment shall be suitably rated for the lifting capacity required.
- Prior to starting the machine and operating hydraulic functions, ensure that you have removed all transport fixtures.
- Do not stand beneath machine components when they are being raised or lowered into the working and transport positions.
- Do not use fingers to check hole alignment. Serious injuries can occur.
- Prior to testing the machine ensure that all tool items, parts and components have been removed from the machine and platforms. Ensure that no one is on or near the machine prior to testing.
- Operate the machine to ensure it is functioning correctly. If any issues or faults occur during operation, switch off the machine immediately and perform the necessary fault finding procedures to rectify the problem. Fault finding procedures shall be performed by experienced and competent personnel.

2.6 Safety Prior & During Operation

NOTICE

The information provided in this operators handbook in regards to setup, operation, maintenance, and the replacement of machine components has been provided based upon the best possible site conditions and setup of the machine. Not every site or machine setup will be the same. In these circumstances the safety instructions given shall be adapted to suit the conditions and setup of each machine.

Personnel performing work on the machine shall evaluate all the on-site risks and take them into account prior to performing any work. All efforts shall be made to find and eliminate all on-site risks associated with this machine.

All components of this machine shall be maintained to a high standard and correctly installed. Any damage to the machine shall be immediately repaired and defective components replaced with genuine parts. Remove any build-up of grease, oil or debris prior to operating the machine.

- Perform the daily maintenance schedule outlined in the maintenance section of this handbook prior to performing any operational tasks.
- Prior to operation inspect the machines condition for worn, broken, missing, or damaged components.
- Ensure that all safety guards and devices are installed on the machine.
- Ensure the emergency stops installed on the machine are fully functional.
- Ensure all personnel operating this machine are competent and experienced with of this type of machinery. Statutory minimum age limits shall also be observed.
- Ensure all safety hazards and operating procedures have been observed and assessed prior to starting the machine.
- Ensure that all required personal protective equipment is worn.
- Loose clothing and jewelry shall be removed to avoid entanglement in the machine.
- Long hair shall be tied back to avoid entanglement in the machine.
- Ensure that bystanders, untrained, or inexperienced personnel are at a safe distance from the machine.
- Prior to operating the machine, perform a walk around. Ensure no personnel are working on the machine or on it.
- Inform all personnel and bystanders that the machine is being placed into operation and to stay at the recommended safe distances that are outlined in this handbook.
- When the machine is operating the use of the ladders, steps, and walkways are only permitted to visually inspect the machine when it is running free of material. Extreme care shall be taken when doing so. Do not inspect the machine while material is being loaded.
- If the machine malfunctions or operates with difficulty, immediately stop the machine and implement the lock and tag out procedure outlined in this handbook. The machine shall not be put into operation until all defects have been investigated and rectified.
- No attempt shall be taken to perform repairs, maintenance, or adjustments of any type while the machine is operating.
- The use of emergency stops is only permitted in an emergency situation. Do not use an emergency stop to shut down the machine.

(1) Exclusion Zone During Operation

NOTICE

A 15 meter (49 ft) exclusion zone (Fig: 2.4) shall be placed around the machine prior to loading any material.

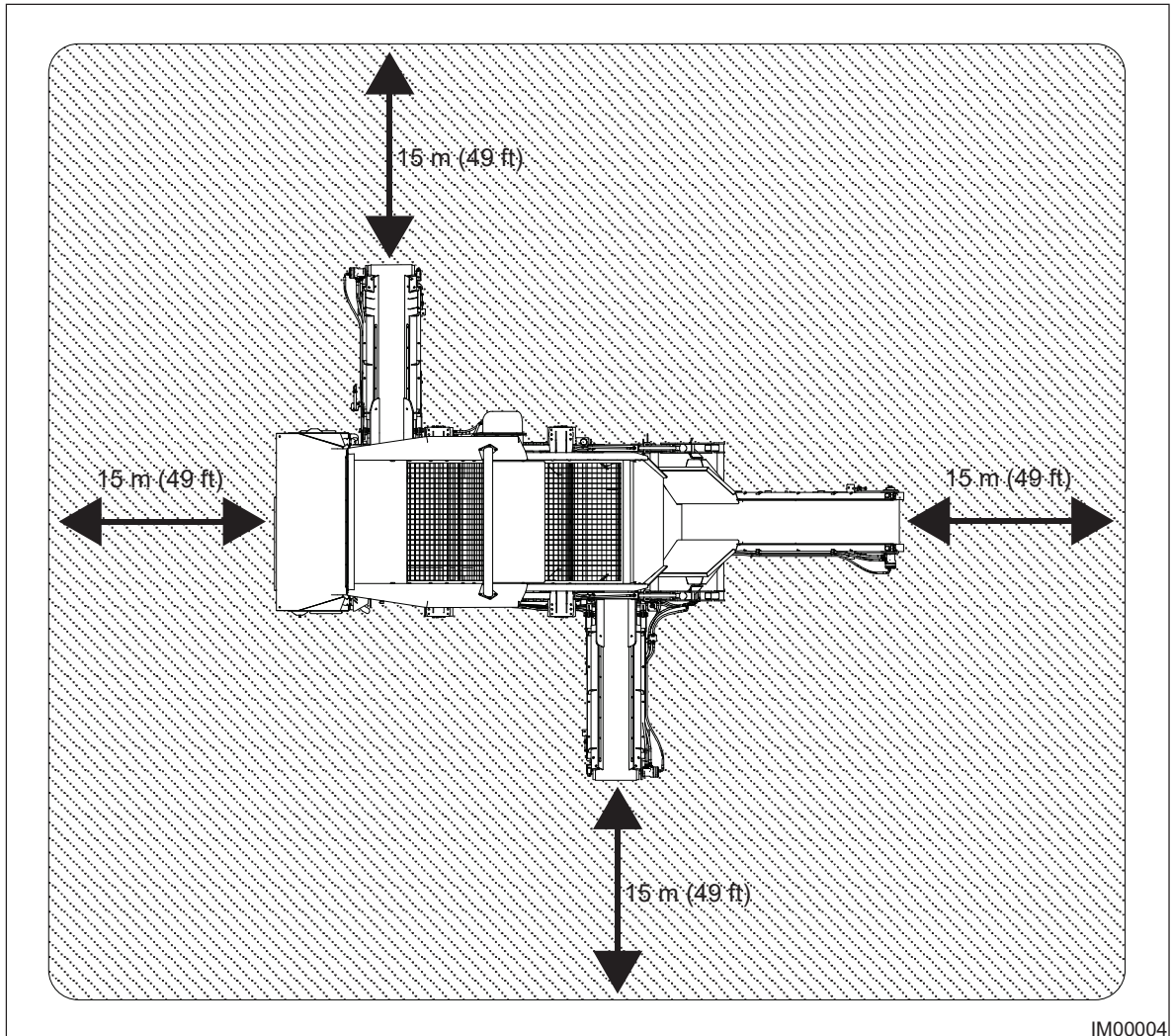

Fig: 2.4 - Exclusion Zone

IM00004

(2) Noise Level During Operation

⚠ CAUTION

Hearing Hazard Exceeds 90 dB (A).

Excessive noise levels are emitted from this machine.

Contact with noise levels exceeding 90 dB over long periods of time can cause serious injury. Exposure to such noise levels should be kept to a minimum where possible. Precautions shall be taken which will include the use of suitably rated ear protection. Adequate noise risk assessments shall be carried out.

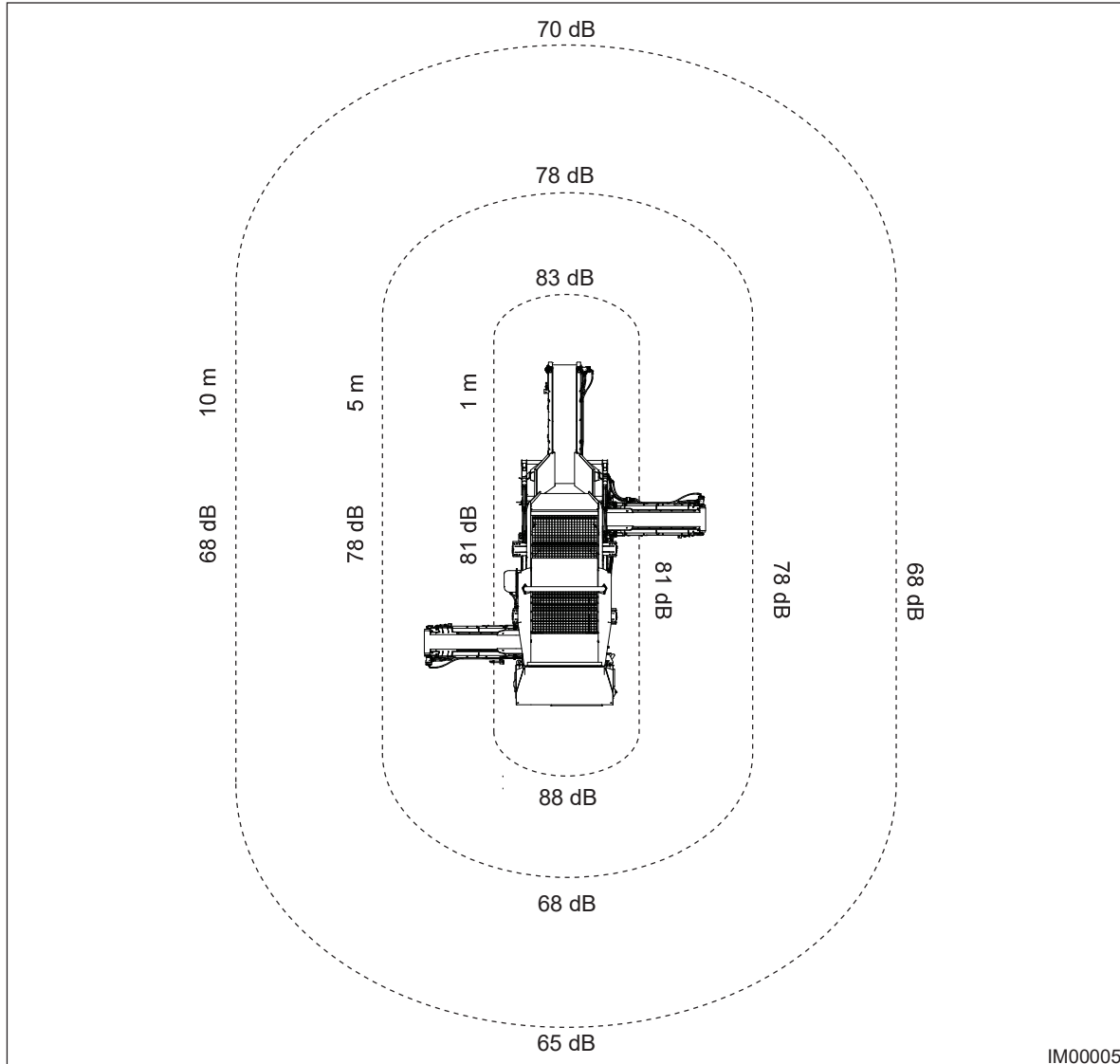

Fig. 2.5 - Noise Level

Noise Level Certification	
Machine Type:	Mobile Screener- RC-S48
Manufacturer:	RUBBLECRUSHER
Standards:	UNI EN ISO 3744
Measurement Type:	Lw dB(A) 108

2.7 Safety Prior & During Maintenance

NOTICE

The information provided in this operators handbook in regards to setup, operation, maintenance, and the replacement of machine components has been provided based upon the best possible site conditions and setup of the machine. Not every site or machine setup will be the same. In these circumstances the safety instructions given shall be adapted to suit the conditions and setup of each machine.

Personnel performing work tasks on this machine shall assess all on-site risks and take these into account prior to performing the required task. All efforts shall be made to find and eliminate all on-site risks associated with this machine. Never modify any components on the machine which can affect safety without consulting and obtaining permission from the machine manufacturer.

- Prior to performing any maintenance procedures on this machine always ensure to implement the lock and tag out procedure outlined within this handbook.
- Ensure a minimum of two people are present when maintenance or service tasks are being performed.
- Ensure that all required personal protective equipment is worn.
- Loose clothing and jewelry shall be removed to avoid entanglement in the machine.
- Long hair shall be tied back to avoid entanglement in the machine.
- Ensure that the personnel performing the maintenance or repair work have a clear understanding of the work required. No untrained or inexperienced personnel are permitted to work on this machine.
- Caution shall be taken when removing filler caps, filters, drain plugs and hydraulic fittings. Hold a cloth over the connection to prevent being sprayed or splashed with fluids. Ensure oils and fluids have cooled prior to working with them.
- Guards and access doors shall be replaced or closed prior to leaving the machine unattended, even for short periods of time. No other personnel other than those who are permitted to work on the machine are to be within the vicinity of the machine.
- Damaged, dirty, or missing hazard signs shall be cleaned or replaced.
- When working on the machine where no work platforms are present, approved work platforms shall be required. Do not climb onto the machine to reach areas that are not accessible from the ground or from platforms. Never use unauthorized or defective platforms to reach inaccessible areas of the machine. When working at height, check with your local law and regulations authority for the specific height requirements.
- Any lifting equipment used, including slings and chains, shall be adequately tested on a routine schedule and suitably rated for the required lifting capacity.
- Do not work beneath unsecured components.
- Ensure machine components have cooled prior to performing maintenance tasks, particularly in the engine compartment and around the exhaust system.
- Implement the routine maintenance schedules that are outlined in the maintenance section of this handbook. More frequent maintenance shall be required when a warning indicator calls for immediate action or the machine is operating in more severe conditions than usual.
- During or after repair or maintenance, inspect all other parts of the machine for damage or wear.
- Prior to testing remove all tools, old parts, and components from the machine and platforms.
- Adjustments to the machine shall not be performed when it is in operation.
- Avoid smoking and naked lights when refuelling or in the refuelling area.

- When servicing and maintenance tasks are complete, test the machine to ensure that it is correctly functioning.
- After testing the machine, check for any loose components, missing bolts, washers or nuts, etc.
- Once the machine has been operating for a few hours, shut down and inspect for any further issues.

2.8 Lock & Tag Out Procedure

WARNING

Lock Out & Tag Out.

This machine shall be locked and tagged out prior to performing maintenance, service or repair work.

Follow written lock and tag out procedures.

Accidental start-up of this machine can cause serious injury or death.

SAFETY INSTRUCTION

When the machine is out of operation or undergoing routine maintenance/service work, it is the responsibility of the operator/service engineer to ensure the machine is isolated correctly. This is done by implementing the lock and tag out procedure.

When the machine is locked and tagged out, never give your key to anyone else. Individuals that are working on the machine shall safe guard their own key and only remove their lock and tag when safe to do so. The machine shall not be able to be operated until all lockout devices are removed.

(1) Implement The Lock & Tag Out

PROCEDURE

1. Observe all safety warnings.
2. Switch off the engine and remove the key from the ignition.
3. Rotate the isolator switch (Fig: 2.6) counter-clockwise from the 'ON' position (Item 1) to the 'OFF' position (Item 2).

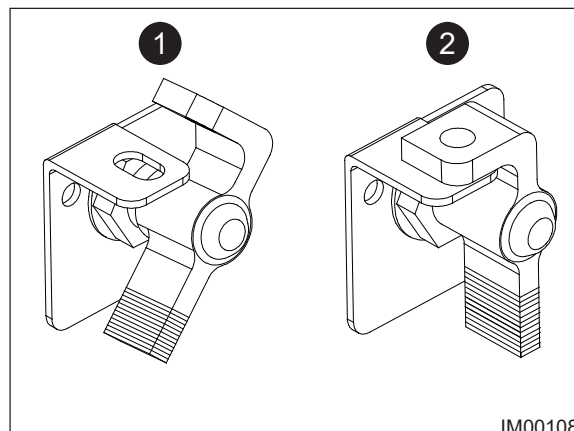

Fig: 2.6 - Isolator Switch

4. Install the lockout clasp (Item 1, Fig: 2.7).

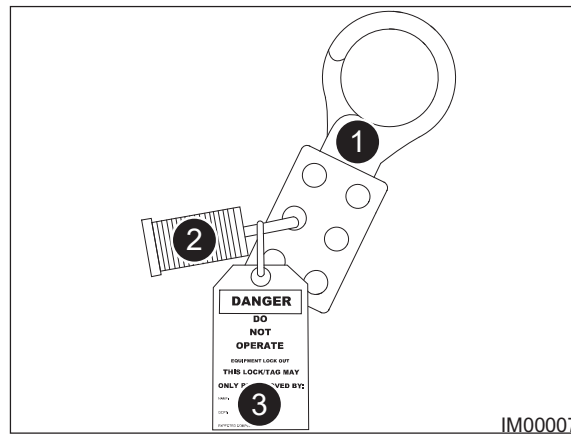

Fig: 2.7 - Lockout Clasp, Lock & Tag

5. Individuals who are permitted to work on the machine are required install their own personal lock and tag to the clasp (Items 2 & 3, Fig: 2.7). The tag shall contain the correct information as in regards to who is working on the machine, the time and date of when it was installed, and the expected completion time of when the task will be complete.
6. Relieve all pressures in the hydraulic system prior to performing any maintenance, service, or repair work. Pressure can remain in the system even after the machine has been switched off.
7. Initiate an emergency stop button as an additional precaution.
8. Try to start the engine.

◇ If the machine is correctly isolated, the engine will not start.

(2) Remove The Lock & Tag Out

PROCEDURE

1. Observe all safety warnings.
2. Prior to proceeding, ensure the following tasks have been performed:
 - All covers, guards, or safety devices that have been removed have been replaced and secured.
 - Machine hazard labels that have been damaged or removed have been replaced.
 - All maintenance equipment and tools have been removed from the machine.
 - If the hydraulic system has undergone maintenance, service or repair work, it has been thoroughly inspected and the system is satisfactory.
 - All personnel have been notified that the lock and tag out procedure is being removed.
3. Remove the tag, padlock, and clasp from the isolator switch (Items 3,2,1, Fig: 2.7).
4. Rotate the isolator switch (Fig: 2.6) clockwise from the 'OFF' position (Item 2) to the 'ON' position (Item 1).
5. Release all engaged emergency stop buttons.
6. Inform all surrounding personnel of machine start-up.

2.9 Emergency Stop Buttons

NOTICE

Inspect the emergency stop buttons when the machine is going to be put into operation. Ensure they are not damaged and the safety labels are in good, identifiable condition.

Ensure that anyone who works on this machine is familiar with the location of the emergency stop buttons.

The stop buttons installed on the umbilical and radio remote handset are not an emergency stop button. The machine can operate with the handset disconnected. These are engine stop buttons and shall only work when connected to the machine.

Emergency stop buttons are to be used only in the event of an emergency. Do not use the emergency stops to shut down the machine in normal operation.

In the event of an emergency and a stop button has been initiated, the conveyor shall require to be cleared of all material manually prior to restarting the machine again.

The emergency stops are clearly indicated on the machine with a safety label (Fig: 2.8).

- ISO Standard (1).
- ANSI Standard (2).

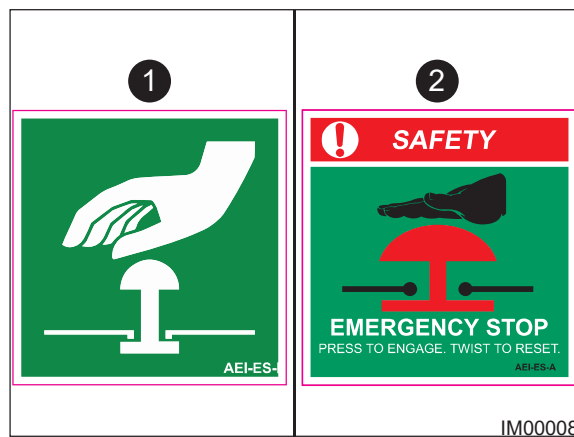

Fig: 2.8 - Safety Label

(1) Emergency Stop Button Locations

NOTICE

There are two emergency stop buttons located on this machine. One is located on the left-hand side of the machine and the other on the right-hand side (Fig: 2.9).

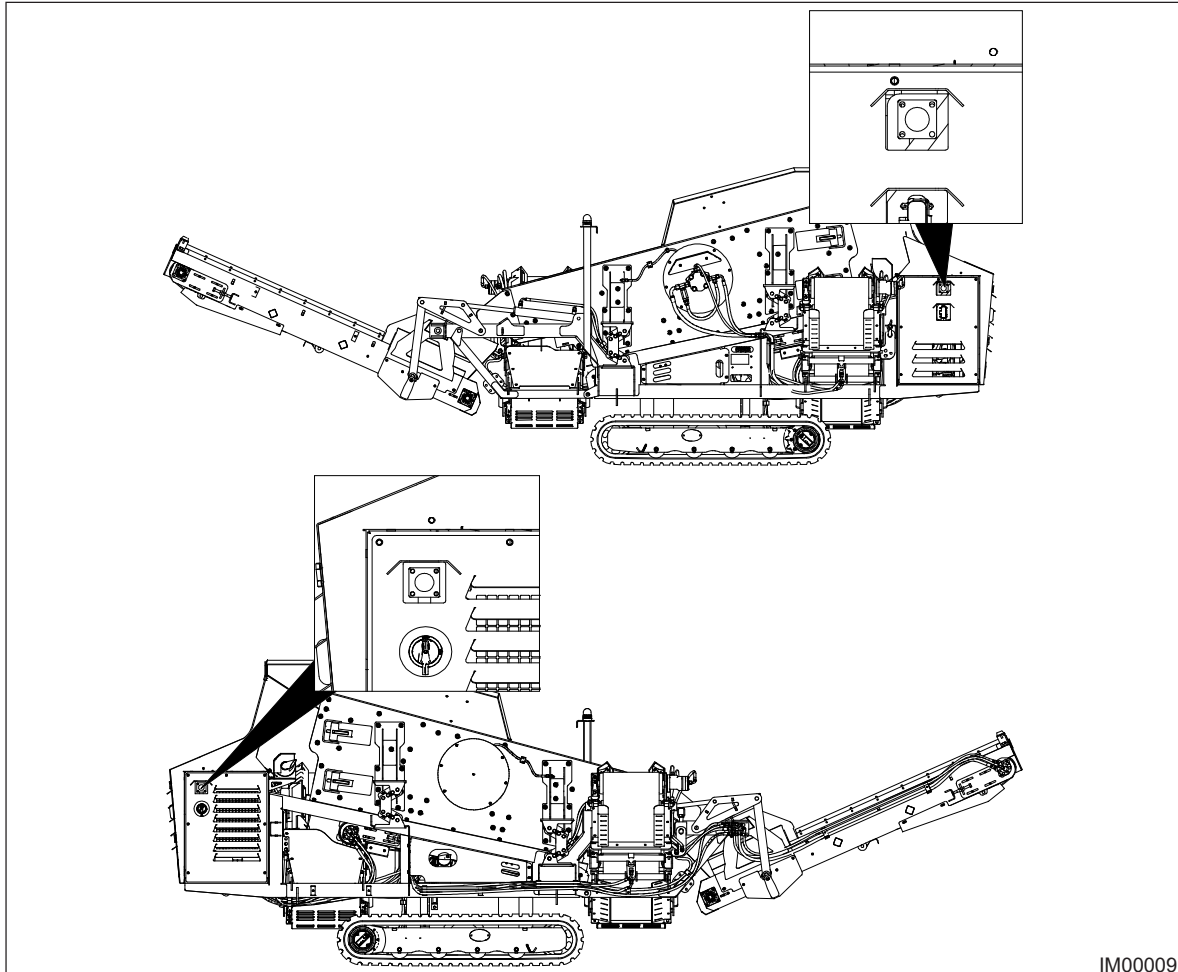

Fig: 2.9 - Emergency Stop Locations

(2) Emergency Shut-Down Procedure**SAFETY INSTRUCTION**

In the event of an emergency, the following procedure shall be implemented immediately.

PROCEDURE

1. In the event of an emergency, it is important to observe the surrounding area of where the emergency stop buttons are located. Ensure there are no hazards present that could cause personal injury. Be fully aware of the situation prior to approaching the machine.
2. When safe to do so, engage the emergency stop button ("Emergency Stop Locations" on page 2-28).
3. Shut down all other equipment loading or working in the vicinity of the machine.
4. Implement the lock and tag out procedure ("Lock & Tag Out Procedure" on page 2-25).
5. Alert all personnel working on, or in the vicinity of the machine of the situation.
6. Only when all components of the machine are stationary and the lock and tag out procedure has been implemented, shall any attempt be made to rectify the issue.
7. A minimum of two people are required when fault finding or performing an accident investigation.

(3) Restarting After Emergency Shut-Down**SAFETY INSTRUCTION**

Only authorised personnel that are experienced in emergency shut down situations with this type of machinery are permitted to re-start the machine after an emergency shut down. Under no circumstances shall the machine be re-started until all necessary precautions have been adhered to.

PROCEDURE

1. Observe all safety warnings.
2. Ensure that the issue has been corrected and all dangers eliminated.
3. Replace all guards, doors, and safety devices as necessary.
4. Ensure that all personnel are clear of the machine.
5. Ensure that all tools, maintenance equipment and any other equipment that is not part of the machine has been removed.
6. Release the emergency stop button by twisting it.
7. Follow the correct engine start up procedure.
8. Do not leave the machine until certain the issue has been rectified.
9. If the issue reoccurs, implement the emergency shut down procedure and perform further fault finding, or contact technical.

Intentionally Left Blank.

Table of Content

3	Technical Data	3-2
3.1	Component Identification	3-2
(1)	Component Description	3-3
3.2	General Information	3-4
(1)	Machine	3-4
(a)	Screen Box.....	3-4
(b)	Oversize Conveyor.....	3-4
(c)	Middle Grade Conveyor	3-4
(d)	Collection Conveyor	3-4
(e)	Fines Grade Conveyor	3-5
(f)	Tracks.....	3-5
3.3	Applications	3-6
3.4	Machine Dimensions	3-7
(1)	Transport Dimensions.....	3-7
(2)	Working Dimensions.....	3-8

3 Technical Data

3.1 Component Identification

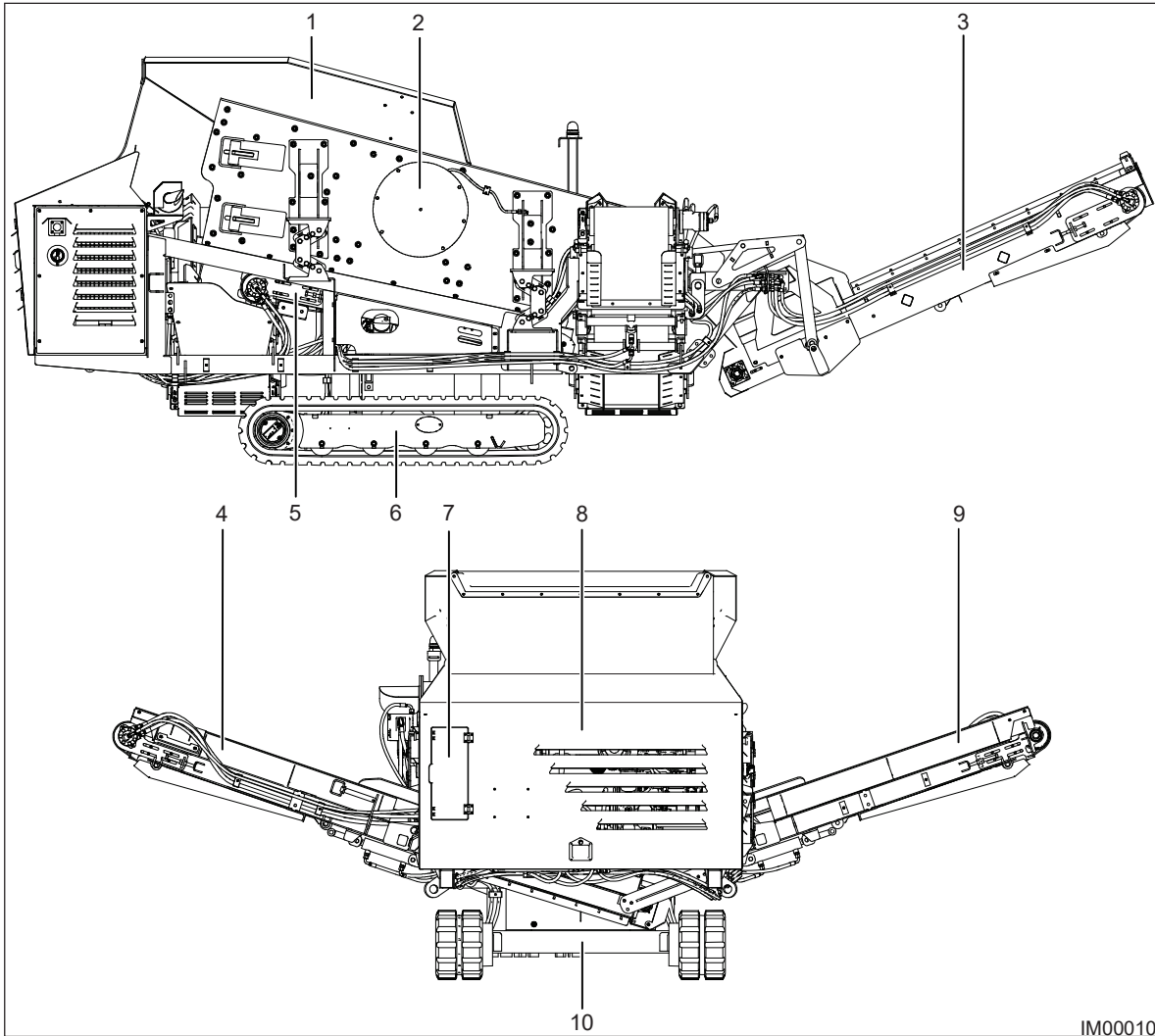

IM00010

Fig: 3.1 - Component Identification

Item	Description
1	Feed Hopper/Feed Chute
2	Vibrating Screen Box
3	Oversize Conveyor
4	Fines Grade Conveyor
5	Collection Conveyor
6	Crawler Tracks
7	Control Panel
8	Engine Compartment
9	Middle Grade Conveyor
10	Chassis

(1) Component Description

The following descriptions are provided for the components listed in "Component Identification" on page 3-2.

- Feed Hopper/Feed Chute (Item 1, Fig: 3.1) - The material is loaded through a variety of means, loading shovels, digger buckets, or direct feed from another machine.
- Vibrating Screen Box (Item 2, Fig: 3.1) - The two deck screen box unit screens raw material into three different grade types of product. The three different grade types of product that are produced are dependant on the screen media that has been installed on the top and bottom deck of the unit.
- Oversize Conveyor (Item 3, Fig: 3.1) - This conveyor discharges the largest material from the screen box unit. This is the material that doesn't pass through the top deck screen box media.
- Fines Grade Conveyor (Item 4, Fig: 3.1) - This conveyor discharges the smallest material from the screen box unit. This material passes through the top and bottom deck screen box media and is captured by the collection conveyor, which then discharges onto the fines grade conveyor.
- Collection Conveyor (Item 5, Fig: 3.1) - This conveyor collects the remaining fines material that has been screened through the top and bottom deck of the screen box unit. The conveyor then discharges this material onto the fines conveyor.
- Crawler Tracks (Item 6, Fig: 3.1) - These are welded to the chassis and are used for transporting the machine.
- Control Panel (Item 7, Fig: 3.1) - Is located inside the engine compartment. It is used for placing the machine into the maneuvering, setup, and operation modes.
- Engine Compartment (Item 8, Fig: 3.1) - This is where the engine, control panel, and hydraulic system for the machine are located.
- Middle Grade Conveyor (Item 9, Fig: 3.1) - This conveyor discharges the mid-size material from the screen box unit. This material passes through the top deck screen box media and is diverted to, and discharged off, the middle grade conveyor.
- Chassis (Item 10, Fig: 3.1) - Steel structured assembly where all machine components are fixed to.

3.2 General Information

(1) Machine

MACHINE	
Machine Type:	Mobile Scalping Screen
Weight:	3850 kg (4.2 US ton)
Remote:	Umbilical, Wireless remote available
Engine:	CAT C1.1 18.4 kW (24hp) EU Stage V, US EPA Tier 4 Final
Fuel Tank:	120L (32 USG)
Hydraulic Tank:	70L (18.5 USG)
Crawler Tracks:	Strickland Rubber Tracks

(a) Screen Box

SCREEN BOX	
Screen Size:	1210mm x 2400mm (4' x 8')
Screen Type:	Double Deck
Speed:	870 rpm
Throw:	10mm
Screen Mesh:	To suit customer requirement
Tension:	End Tensioned
Drive:	Hydraulic
TPH:	80 tph

(b) Oversize Conveyor

OVERSIZE CONVEYOR	
Hydraulics:	Hydraulic folding & Hydraulically driven
Discharge Height:	1417mm (4' 7")
Belt:	Chevron
Width:	500mm (20")

(c) Middle Grade Conveyor

MIDDLE GRADE CONVEYOR	
Hydraulics:	Hydraulic folding & Hydraulically driven
Discharge Height:	1307mm (4' 3")
Belt:	Chevron
Width:	400mm (16")

(d) Collection Conveyor

COLLECTION CONVEYOR	
Hydraulics:	Hydraulically driven
Belt:	Flat
Width:	1000mm (39")

(e) Fines Grade Conveyor

FINES GRADE CONVEYOR	
Hydraulics:	Hydraulic folding & Hydraulically driven
Discharge Height:	1303mm (4' 3")
Belt:	Chevron
Width:	400mm (16")

(f) Tracks

TRACKS	
Min. Travel Speed	1.88 km/h (1.2 mph)
Max. Travel Speed	3.29 km/h (2.0 mph)
Gradeability	15°
Torque	1652 N m (1218 ft-lb)

3.3 Applications

NOTICE

Contact the machine manufacturer if the application required is not listed below. Damage to the machine can occur if operated out of its recommended application.

- Crushed Stone
- Sand and Gravel
- Iron Ore
- Construction & Demolition
- Coal
- Grain
- Refuse
- Top soil
- Wood bark
- Wood chips
- Scalping

3.4 Machine Dimensions

(1) Transport Dimensions

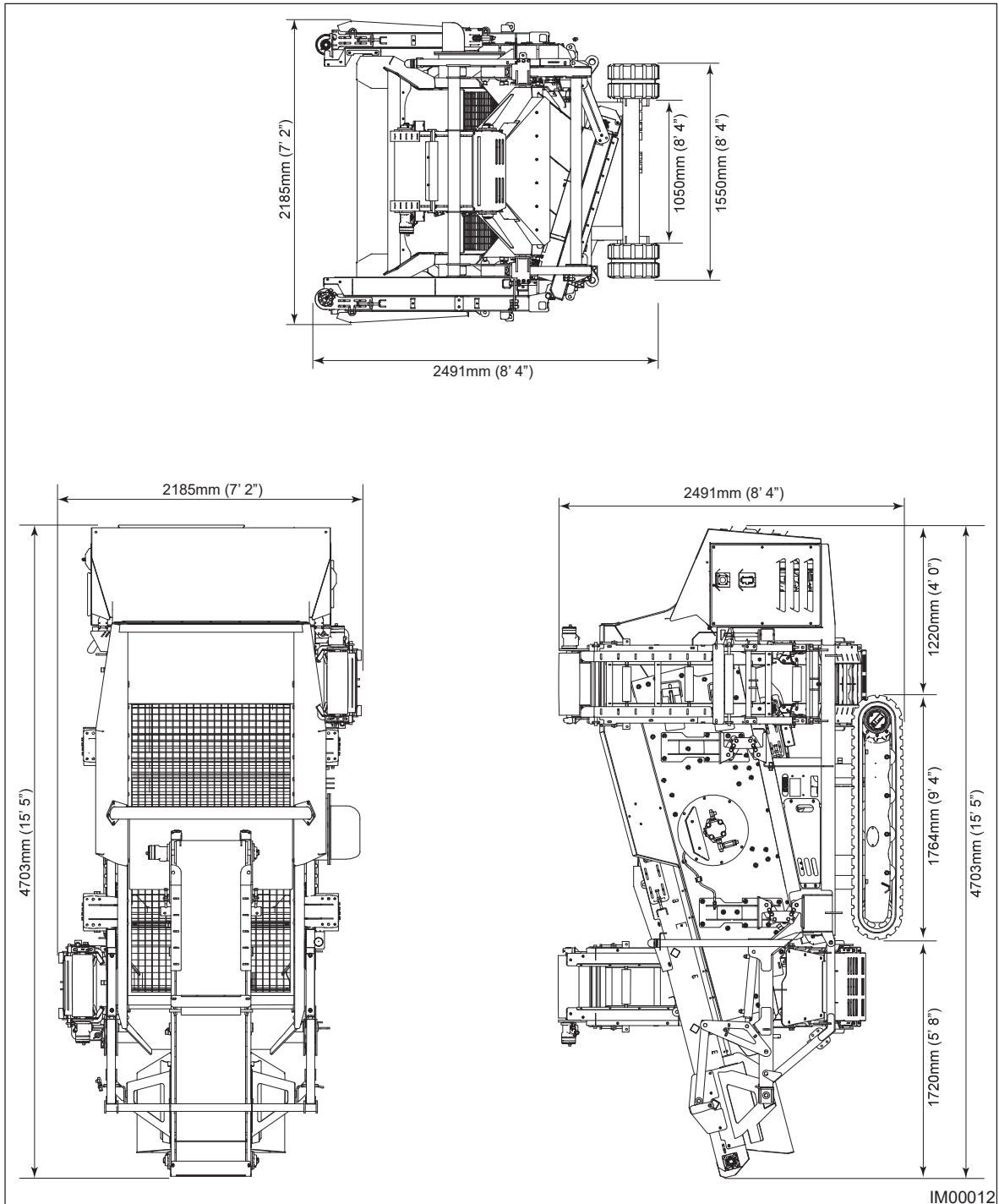
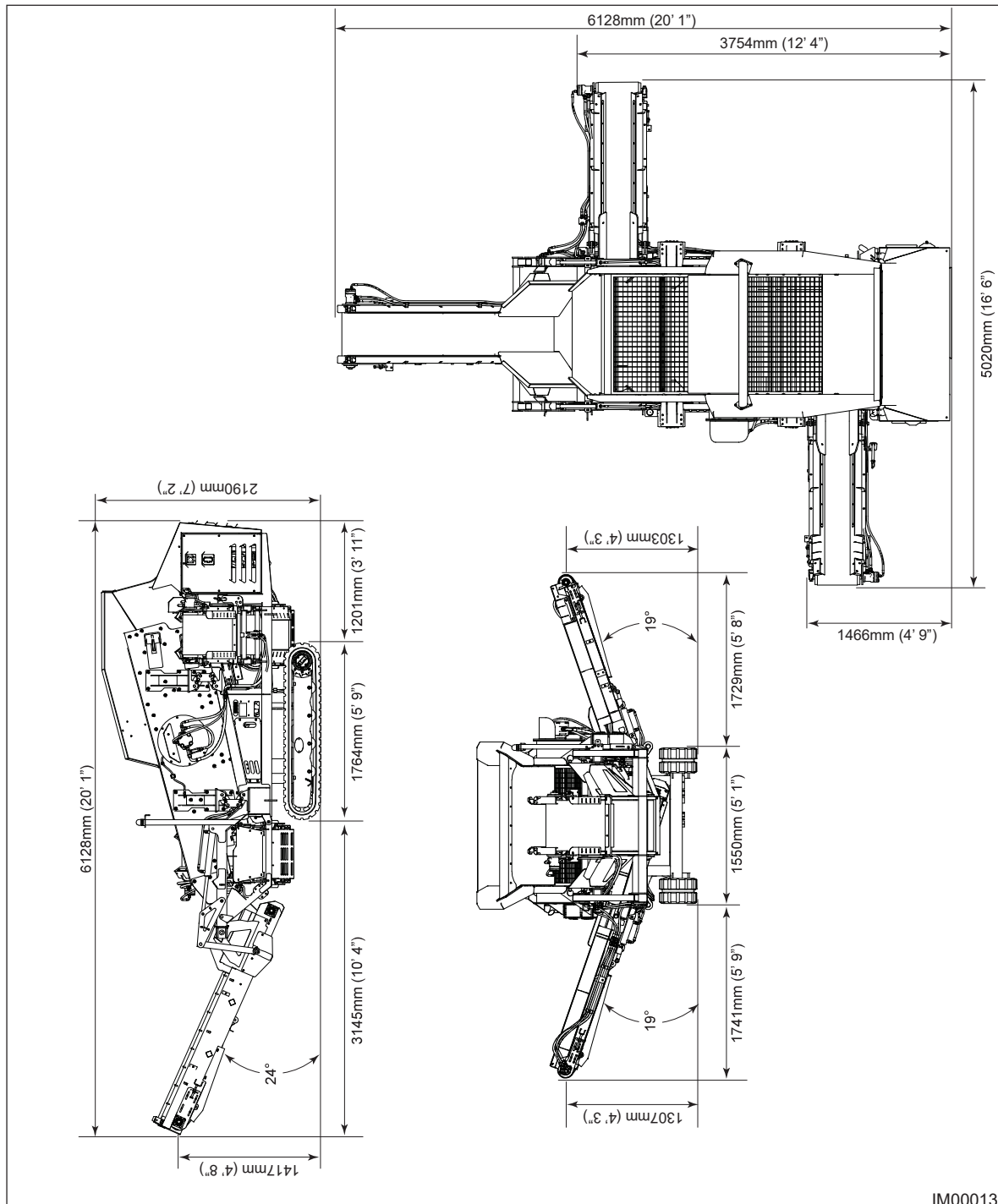

Fig: 3.2 - Transport Dimensions

TRANSPORT DIMENSIONS	
Height:	2491mm (8' 2")
Width:	2185mm (7' 2")
Length:	4703mm (15' 5")

(2) Working Dimensions



IM00013

Fig: 3.3 - Working Dimensions

WORKING DIMENSIONS	
Height:	2190mm (7' 2")
Width:	5020mm (16' 5")
Length:	6128mm (20' 1")

Table of Content

4	Product Familiarisation	4-2
4.1	Machine Orientation.....	4-2
4.2	Control Panel Familiarisation	4-3
	(1) Control Panel Functions	4-3
4.3	Control Panel Menu Screens	4-4
	(1) Menu Screen Common Icons	4-4
	(a) Radio Remote Control Icon Status.....	4-4
	(b) Service Icon Status	4-5
	(2) Splash Screen	4-5
	(3) Home Screen.....	4-6
	(a) Warning Lamps	4-6
	(b) Engine Information	4-7
	(4) Machine Operating Screen	4-8
	(5) Menu Select Screen	4-9
	(a) Machine Information Screen	4-10
	(b) Machine Fault Log Screen	4-11
	(c) Settings Screen	4-12
	(6) Tracking Screen.....	4-13
	(7) Machine Pop-Up Screens.....	4-14
	(a) Machine Fault Pop-Up Screen	4-14
4.4	Umbilical & Radio Remote Handsets	4-15
	(1) Umbilical Handset.....	4-15
	(2) Radio Remote Handset	4-16
4.5	Hydraulic Controls	4-17

4 Product Familiarisation

NOTICE

It is important that the operator is familiar with all aspects of this machine. The contents of this handbook shall be read and fully understood prior to performing any operating procedures.

Misuse of this machine can cause damage to the equipment and unnecessary downtime.

4.1 Machine Orientation

CAUTION

It is important to identify the machine orientation when maneuvering. Understand both the machine orientation and the control functions of the umbilical and radio remote handsets prior to moving this machine ("Maneuvering The Machine" on page 6-2).

The full content of this operators handbook shall be read and fully understood prior to maneuvering.

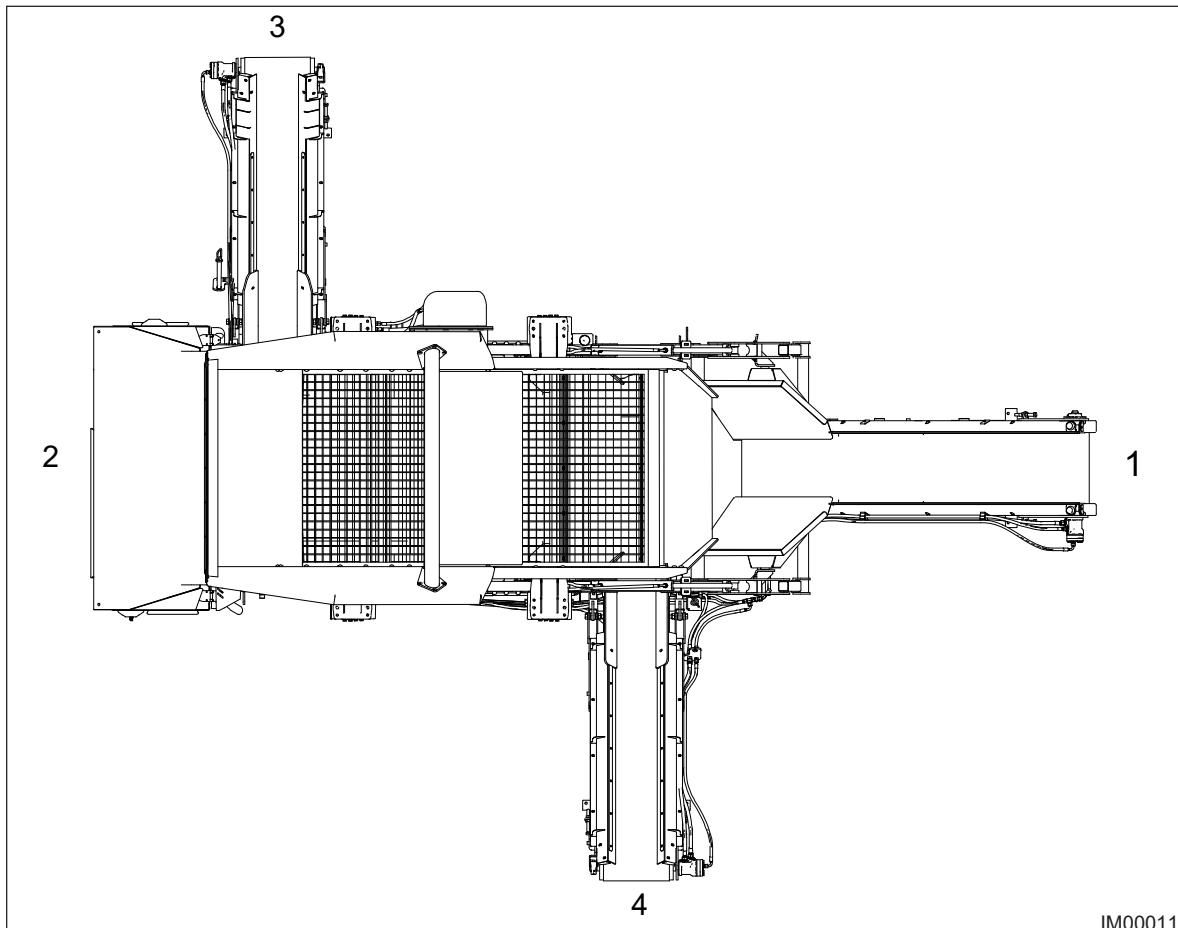

Fig: 4.1 - Machine Orientation

IM00011

Item	Position
1	Front
2	Rear
3	Left
4	Right

4.2 Control Panel Familiarisation

(1) Control Panel Functions

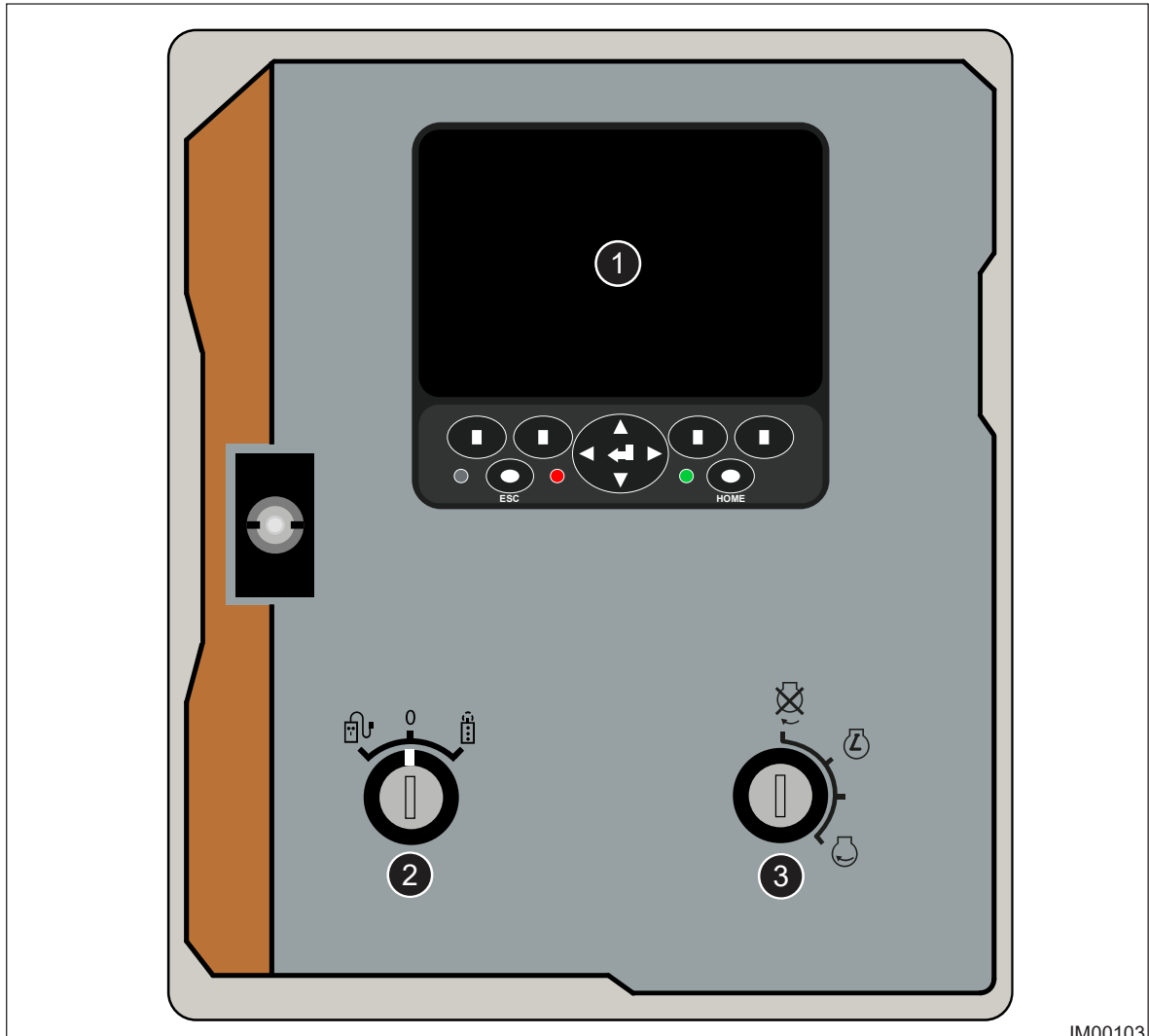

IM00103

Fig: 4.2 - Control Panel

Item	Description	Function
1	Main Control Panel Display	The display screen incorporates an operating system which controls the machines functions. Press buttons are located along the bottom of the screen. These buttons allow the operator to navigate through numerous menu screens ("Control Panel Menu Screens" on page 4-4) and operate the machine.
2	Tracking Switch	The tracking switch allows the operator to select the required handset: Counter-Clockwise Position = Umbilical Handset Centre Position = Off / Disabled Clockwise Position = Wireless Remote Handset
3	Ignition Key	First stage position, is OFF. Second stage position, powers up the control panel. Third stage position, cranks the engine.

4.3 Control Panel Menu Screens

The display screen allows the operator to perform machine functions, view machine status & settings, and observe engine & machine fault codes.

The operator can navigate through the menu screens using the buttons located below the display (Fig: 4.3).



Fig: 4.3 - Display Unit

Item	Function
1	Button 1
2	Button 2
3	Button 3
4	Button 4
5	Scroll Up, Down, Left, Right & Enter
6	Escape Button
7	Mode Button (Unused)

(1) Menu Screen Common Icons

NOTICE

If the radio remote control is connected to the machine and powered up or the machine requires the routine service schedule adhered to, the following icons will display on the menu screens.

(a) Radio Remote Control Icon Status

Radio Remote Control Status	
	Weak Signal
	Average Signal
	Strong Signal

(b) Service Icon Status

Service Interval Icon	
	Weak Signal

(2) Splash Screen

When the machine is first powered up, the Splash Screen (Fig: 4.4) is displayed for a few seconds.



Fig: 4.4 - Splash Screen

(3) Home Screen

Once the Splash Screen extinguishes (Fig: 4.4), the Home Screen will display (Fig: 4.5).

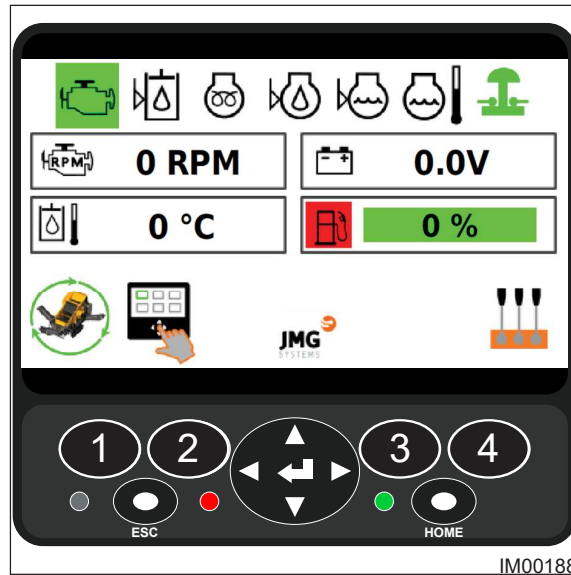
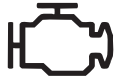







Fig: 4.5 - Home Screen

Button	Description
1	Go To Machine Operating Screen
2	Go To Menu Select Screen
3	N/A
4	Activate Hydraulic Levers





(a) Warning Lamps

Warning Lamps	
 Engine Lamp	Green = OK to start and run Red = Engine cannot start or run due to fault
 Hydraulic Oil Level Lamp	White = No Fault Red = Hydraulic oil level low
 Glow Plugs Lamp	White = Not on Yellow = Glow plugs are on (will only come on when ignition key is turned to crank position while 10 second warning delay is sounding, before starter engages)
 Engine Oil Lamp	White = Oil OK while engine running Red = Engine oil fault (always red when the engine is not running, it will extinguish when the engine starts and oil is detected at the sensor. If a fault occurs it will illuminate again)

Warning Lamps	
 Coolant Level Lamp	White = No Fault Red = Coolant level low
 Coolant Temperature Lamp	White = No Fault Red = Coolant Temperature High
 Estop Lamp	Estops healthy Red = Estop Pressed

(b) Engine Information

On the Home Screen (Fig: 4.5) the following Engine Information can be observed.

Engine Information	
 0 RPM	Engine RPM
 0.0V	Battery Voltage
 0 °C	Hydraulic Oil Temperature
 0%	Fuel Level

(4) Machine Operating Screen

The Machine Operating Screen (Fig: 4.6), is accessed by pressing Button 1 on the Home Screen (Fig: 4.5).



Fig: 4.6 - Machine Operating Screen

BUTTON 1	BUTTON 2	BUTTON 3	BUTTON 4
Auto Run – Hold for 5 seconds	Oversize & Middle Grade Conveyor Start/Stop	Collection & Fines Conveyor Start/Stop	Vibrating Screen Box Start/Stop

UP	LEFT	ENTER	RIGHT	DOWN
Increase Engine RPM	N/A	N/A	N/A	Decrease Engine RPM

BUTTON 5	BUTTON 6
ESC - Previous Page	HOME - Go to Home Page

(5) Menu Select Screen

The Menu Select Screen (Fig: 4.7), is accessed by pressing Button 2 on the Home Screen (Fig: 4.5). Use the Arrow Keys to navigate to the page you wish to select and press Enter to open selected menu.

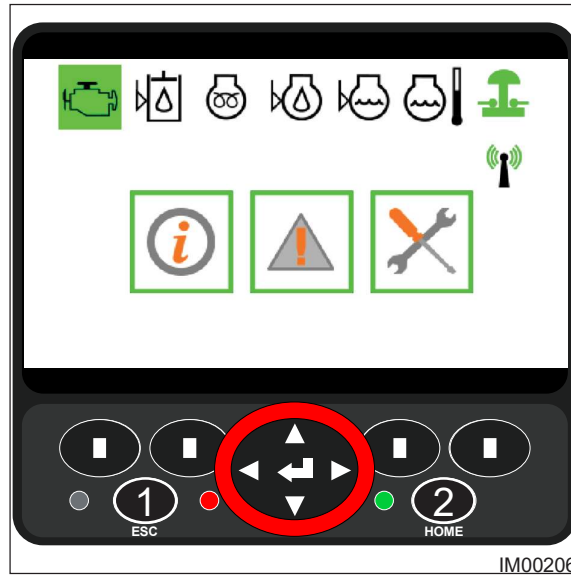





Fig: 4.7 - Machine Operating Screen

Menu Select Options		
		
Machine Information	Machine Faults Log	Settings

BUTTON 1	BUTTON 2
ESC - Previous Page	HOME - Go to Home Page

(a) Machine Information Screen

The Machine Information Screen (Fig: 4.8) is accessed from the Menu Select Screen (Fig: 4.7). It provides information on the display and controller software versions, the number operating hours for both the machine and engine, and the hours since the last service was completed.

After each service reset the service interval back to 0 Hours. Press and hold the Enter button to reset the service indicator.

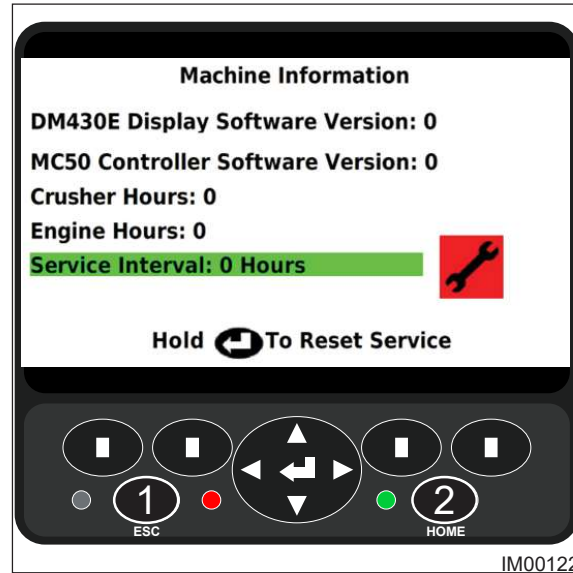

Fig: 4.8 - Machine Information Screen

BUTTON 1	BUTTON 2
ESC - Previous Page	HOME - Go to Home Page

(b) Machine Fault Log Screen

NOTICE

Do not operate the machine with a fault. The fault shall be rectified and cleared from the log prior to placing the machine back into operation.

The Machine Fault Log Screen (Fig: 4.9) is accessed from the Menu Select Screen (Fig: 4.7) and contains the history of all faults. All faults can be cleared by pressing the enter button.

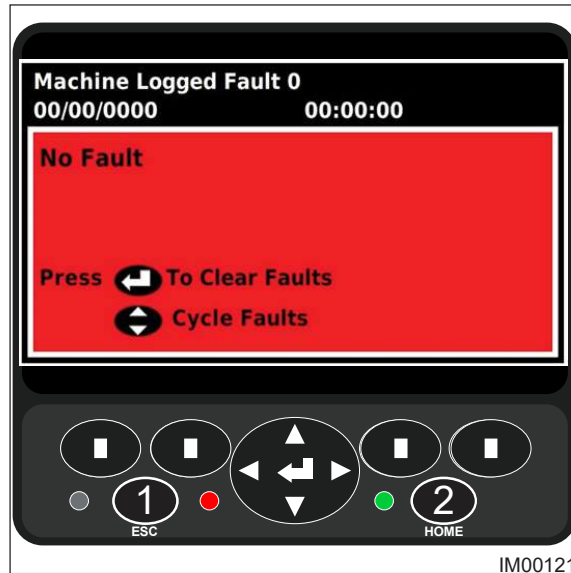

Fig: 4.9 - Machine Fault Log Screen

BUTTON 1	BUTTON 2
ESC - Previous Page	HOME - Go to Home Page

(c) Settings Screen

The Settings Screen (Fig: 4.10) is accessed from the Menu Select Screen (Fig: 4.7). The User Settings is the only one the operator can access. The factory settings are pass coded, preset settings and shall not be altered. Access the user settings screen by using the arrow buttons and pressing enter.

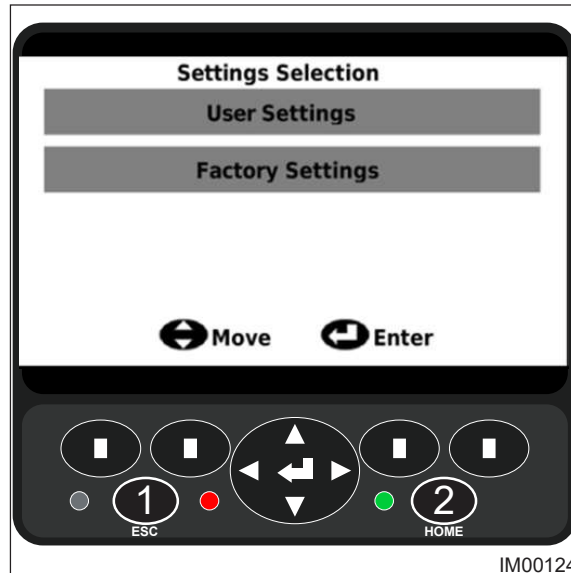

Fig: 4.10 - Settings Screen

BUTTON 1	BUTTON 2
ESC - Previous Page	HOME - Go to Home Page

User Settings Screen

When in the User Settings Screen (Fig: 4.11), use the arrow and enter buttons to select and edit the required setting

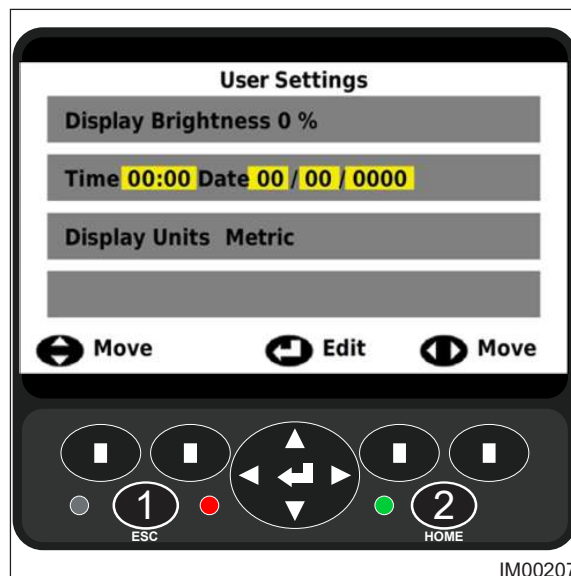

Fig: 4.11 - User Settings Screen

BUTTON 1	BUTTON 2
ESC - Previous Page	HOME - Go to Home Page

(6) Tracking Screen



Crush Hazard.

Death or serious injury can result from contact with the crawler tracks when moving.
Keep clear of crawler tracks when the machine is maneuvering.



Do not operate the umbilical or radio remote handset without fully understanding the control functions and the machines orientation. Only competent and trained operators are permitted to maneuver this machine.

There are two methods available for maneuvering this machine:

- Umbilical Control Handset
- Radio Remote Control Handset

When the umbilical or optional radio remote handset is selected via the selector switch on the control panel and the corresponding handset is turned on, the Tracking Screen (Fig: 4.12) will automatically display.

When the tracking screen is displayed, press Button 1 (Fig: 4.12) to enable tracking.

- ◇ *The tracks symbol above the button will flash orange and the siren delay will start. When the siren delay completes, the icon will change to green and operator can move the machine. The siren will continue to sound while tracks are live. If handset is turned off or track button is pressed on remote again this screen will disappear.*

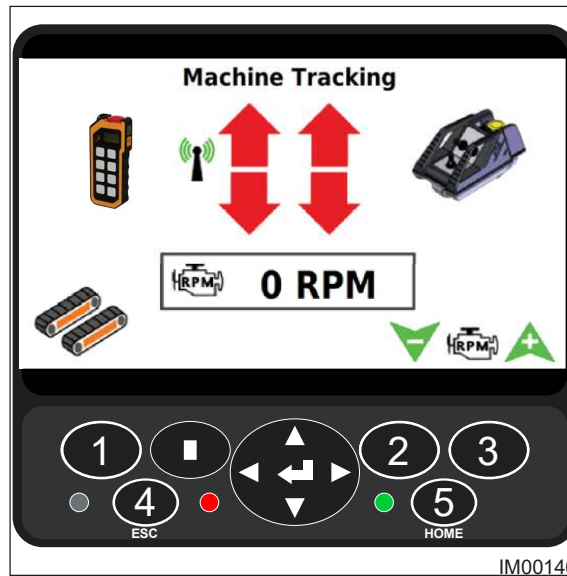

Fig: 4.12 - Track Screen

BUTTON 1	BUTTON 2	BUTTON 3	BUTTON 4
Enable Tracking	N/A	Decrease Engine RPM	Increase Engine RPM

BUTTON 5	BUTTON 6
ESC - Previous Page	HOME - Go to Home Page

(7) Machine Pop-Up Screens

(a) Machine Fault Pop-Up Screen

The machine fault screen (Fig: 4.13) will pop up automatically with a description if a fault is active. The operator can press Enter to clear the fault, but the fault will come on again until the issue is resolved.



Fig: 4.13 - Machine Fault Pop-Up Screen

4.4 Umbilical & Radio Remote Handsets

DANGER

Crush Hazard.

Death or serious injury can result from contact with the crawler tracks when moving.

Keep clear of crawler tracks when the machine is maneuvering.

SAFETY INSTRUCTION

Do not operate the umbilical or radio remote handset without fully understanding the control functions and the machines orientation. Only competent and trained operators are permitted to maneuver this machine.

NOTICE

For placing the machine in track mode, refer to "Maneuvering The Machine" on page 6-2.

(1) Umbilical Handset

CAUTION

When possible, and if installed, use the radio remote control handset to obtain maximum distance from the machine when maneuvering. When using the umbilical handset extra caution shall be taken to avoid any potential hazards due to the restrictions of the cable.

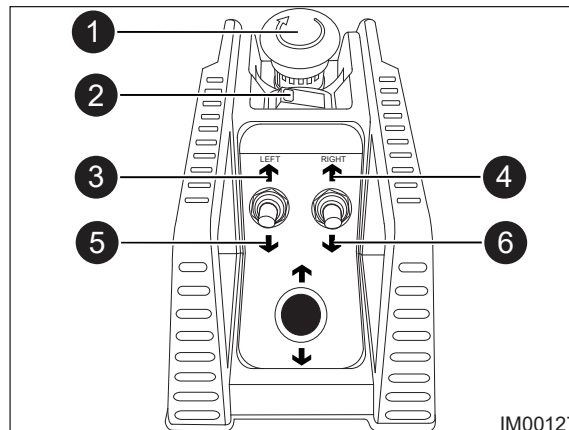

Fig: 4.14 - Umbilical Handset

Item	Function
1	Emergency Stop Button
2	Handset ON/OFF Switch
3	Left Track Forward
4	Right Track Forward
5	Left Track Reverse
6	Right Track Reverse

(2) Radio Remote Handset

The radio remote control handset is the safest method for maneuvering the machine. It allows the operator to move the machine without the restriction of a cable and also provides more visibility around the machine.

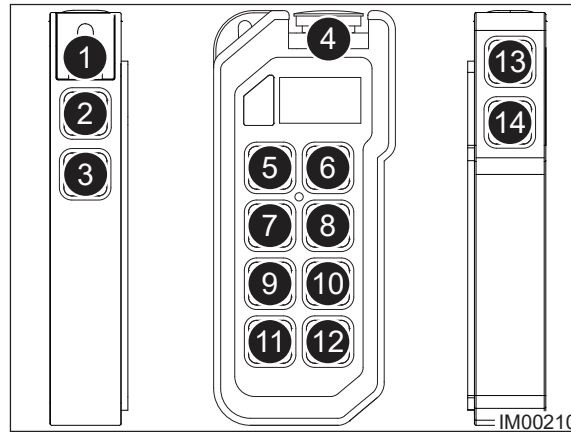

Fig: 4.15 - Radio Remote Handset

Item	Function
1	Mode Switch (Screener/Off/Tracks)
2	Both Tracks Forward
3	Both Tracks Reverse
4	Engine Stop Button
5	Left Track Forward
6	Right Track Forward
7	Left Track Reverse
8	Right Track Reverse
9	Manual - Oversize & Middle Grade Conveyor Start/Stop
10	Manual - Collection & Fines Conveyor Start/Stop
11	Manual - Vibrating Screen Box Start/Stop
12	Activate Tracks
13	Activate Remote
14	Activate Auto Run

4.5 Hydraulic Controls

WARNING

Crush Hazard.

Contact with moving conveyors can result in serious injury or death. Stay clear of all conveyors when folding or unfolding.

SAFETY INSTRUCTION

When setting the machine up the operator shall have read and understood the full contents of this operator's handbook.

Located on the left-hand side of the machine are the hydraulic control levers (Fig: 4.16) which are used for folding and unfolding the conveyors. The C.

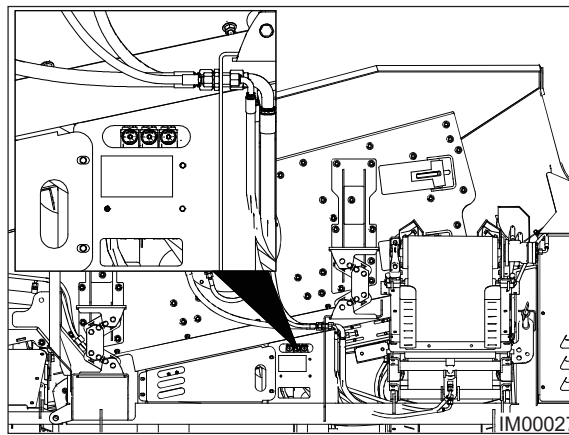

Fig: 4.16 - Control Levers

The three control levers are labelled as follows (Fig: 4.17):

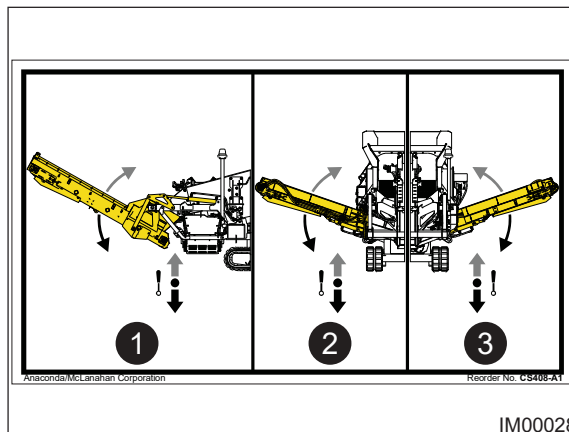

Fig: 4.17 - Control Levers

Item	Function
1	Oversize Conveyor Fold/Unfold
2	Mid Size Conveyor Fold/Unfold
3	Fines Size Conveyor Fold/Unfold

Pushing the control lever UP will fold the conveyor and DOWN will unfold.

Intentionally Left Blank.

Table of Content

5	Engine Start-Up.....	5-2
5.1	Prior To Starting The Engine.....	5-2
5.2	Starting The Engine	5-3

5 Engine Start-Up

CAUTION

Only experienced and trained operators, familiar with this type of equipment are permitted to operate this machine.

The operator shall read and understand the full content of this handbook prior to starting the engine or performing any operating procedures.

5.1 Prior To Starting The Engine

NOTICE

Prior to starting the engine on this machine the operator shall perform the following checks.

PROCEDURE

1. Assess and evaluate the work environment the machine is going into and take all necessary precautions to eliminate all potential risks.
2. Ensure all switches on the control panel are in the OFF or NEUTRAL position.
3. Ensure all hydraulic levers are in the neutral position.
4. Ensure the emergency stop buttons are released.
5. Ensure that there is sufficient fuel in the tank to operate the machine. The tank shall be filled at the end of the working shift to prevent overnight condensation build-up.
6. Ensure the hydraulic oil level is adequate and top-up if necessary.
7. Ensure the engine oil level is adequate and top-up if necessary.
8. Ensure the radiator coolant level is adequate and top-up if necessary.
9. Ensure the machine has no oil or coolant leaks.
10. Ensure the engine radiator and hydraulic oil coolers (if installed) are clean and free from material build-up.
11. In dusty environments, consider wind direction to minimize the possibility of dust entering the air intake.
12. Perform the routine daily (10 hour) maintenance interval.
13. Perform a final check around the machine to ensure no personnel are on or near the machine.
14. As well understanding the full contents of this handbook, it is important to read and understand the full content of engine manufacturer's handbook prior to starting the engine.

5.2 Starting The Engine

NOTICE

Do not crank the starter for more than 30 seconds at a time. It will help protect the batteries when waiting for at least two to three minutes between each start-up attempt.

PROCEDURE

1. Observe all safety warnings.
2. Perform all tasks outlined in "Prior To Starting The Engine" on page 5-2.
3. Place the throttle lever into the IDLE position (Fig: 5.1).

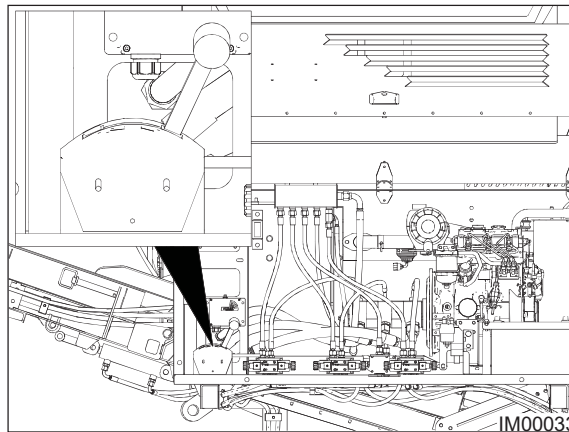

Fig: 5.1 - Throttle Lever

4. Proceed to the Isolator Switch (Fig: 5.2) and rotate the switch Clockwise from the OFF position (Item 1) to the ON position (Item 2).

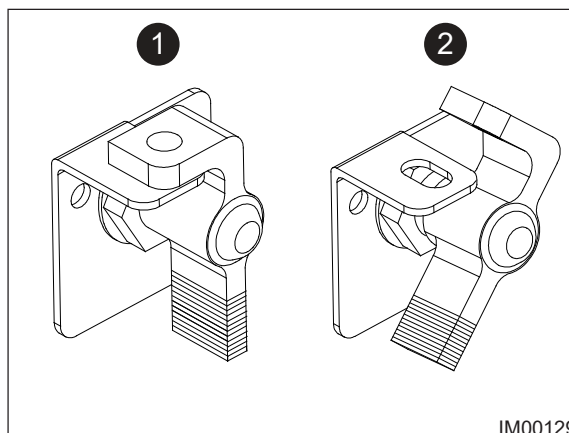

Fig: 5.2 - Isolator Switch

5. Proceed to the main control panel.
6. Ensure the Track Switch (Item 1, Fig: 5.3) is in the Neutral / Off position.

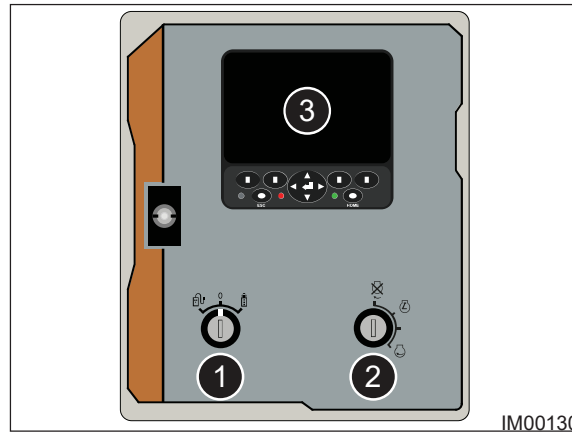

Fig: 5.3 - Control Panel

7. Insert the Ignition Key (Item 2, Fig: 5.3) and rotate to the First Click position (Fig: 5.4).
◇ Allow the display (Item 3, Fig: 5.3) to power-up.

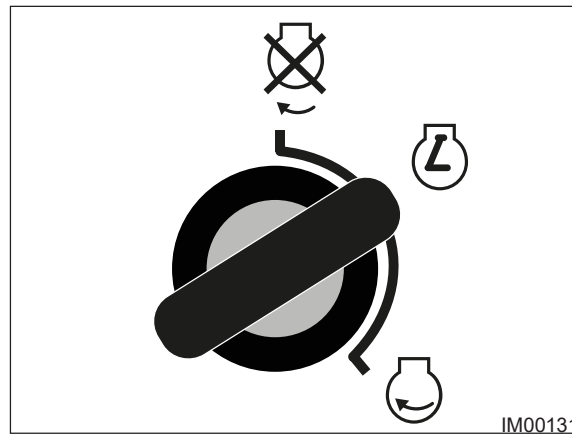

Fig: 5.4 - Ignition First Click Position

8. Once the display has powered up, rotate the Ignition Key to the Crank position and hold (Fig: 5.5).

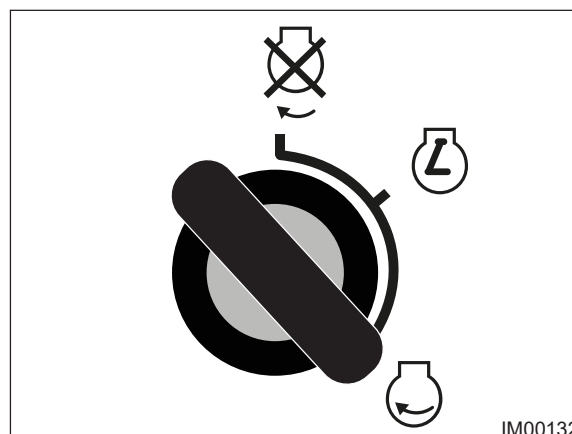

Fig: 5.5 - Ignition Crank Position

9. If the engine fails to start after 30 seconds, release the key and allow the starter to cool for a few minutes. Return the key to the OFF position, then repeat this procedure.
10. Once the engine has started, allow the engine to idle for three to five minutes. This allows the water temperature to increase to working condition.

Table of Content

6	Maneuvering The Machine	6-2
6.1	Safe Maneuvering Instructions	6-2
	(1) Checks Prior To Maneuvering	6-2
	(2) Operating Precautions	6-4
	(3) Crawler Track Working Conditions.....	6-5
6.2	Maneuvering With Umbilical Handset.....	6-6
	(1) Umbilical Handset - Direction Of Travel.....	6-9
6.3	Maneuvering With Radio Remote Handset.....	6-10
	(1) Radio Remote Handset - Direction Of Travel	6-13

6 Maneuvering The Machine

DANGER

Crush Hazard.

Death or serious injury will result from contact with the crawler tracks when moving.

Keep clear of crawler tracks when the machine is maneuvering.

Electrocution Hazard.

Death or injury will result from contacting electric power lines.

Be aware of overhead power lines and cables routed along the ground when folding or moving the machine.

Always maintain the required clearance.

Always contact the electric power line owner if cables or power lines require to be disconnected. The electric supply shall be disconnected or the power lines moved or insulated prior to performing machine operations.

CAUTION

Only experienced and trained operators, familiar with this type of equipment are permitted to operate this machine.

The operator shall read and understand the full content of this handbook prior to starting the engine or performing any operating procedures.

SAFETY INSTRUCTION

Do not operate the umbilical or radio remote handset without fully understanding the control functions and the machines orientation.

6.1 Safe Maneuvering Instructions

(1) Checks Prior To Maneuvering

1. Potential hazards can prevail when maneuvering this machine. Extreme caution shall be taken.
2. Maneuvering this machine shall only be performed by fully trained and competent personnel.
3. Prior maneuvering this machine, perform the following checks:
 - Ensure that the controls on the umbilical handset or radio remote control are operating freely with no issues or damage.
 - Ensure there is no damage to the umbilical handset, cable or plug.
 - Inspect the handset for any signs of water damage. If any part of the umbilical or radio remote handset is damaged or is showing signs of water damage, replace the handset immediately. Do not risk using a faulty handset.
 - Ensure that the correct umbilical handset for the machine is being used. Umbilical handsets can be similar to ones used on other machines but the operation may be significantly different and could cause the machine to operate erratically.
 - Ensure the crawler tracks are free from obstructions, build-up of material.
 - In cold climate conditions, ensure the crawler tracks are not frozen to the ground.
 - Inspect the crawler tracks for signs of oil leaks or damage to any of the components.

Maneuvering The Machine

- Ensure the correct track tension has been set accordingly (Refer to Maintenance). If any issues are present, ensure corrective action is taken prior to maneuvering the machine.
- Never attempt to push or tow the machine and never drag or help to slew the machine sideways.
- Never park the machine in confined spaces. Ensure it is at least 4 metres from walls or other machines.

(2) Operating Precautions

When maneuvering this machine:

- Ensure the terrain the machine is working on is firm enough to adequately support the machine.
- Ensure the track systems are free from debris before maneuvering the machine.
- Make certain the tracks are not frozen to the ground before maneuvering the machine.
- Ensure that no personnel are standing on or close to the machine.
- Do not maneuver the machine up or down slopes which are more than 15°.
- Avoid maneuvering over sharp objects that may damage the rubber tracks.
- The machine shall only be maneuvered using low engine speed, particularly when loading or unloading from a transport vessel.
- When using the umbilical handset, use the full length of the lead and maintain a safe position that provides maximum viewing around the machine to help avoid any obstacles or dangers. Ensure the umbilical cable is kept clear from the tracks to avoid any damage.
- Keep the movement of the machine as smooth as possible. Erratic movement can cause damage to the machines components, crawler tracks included.
- Park the machine on flat, level ground. If it is necessary to park the machine on a gradient, the tracks shall be solidly blocked.
- Do not park the machine in confined spaces. Allow at least 4 metres from walls or other machines.
- When traveling up a gradient (Item 1, Fig: 6.1), the tracks should be driven idlers first (i.e. drive sprocket to the rear).

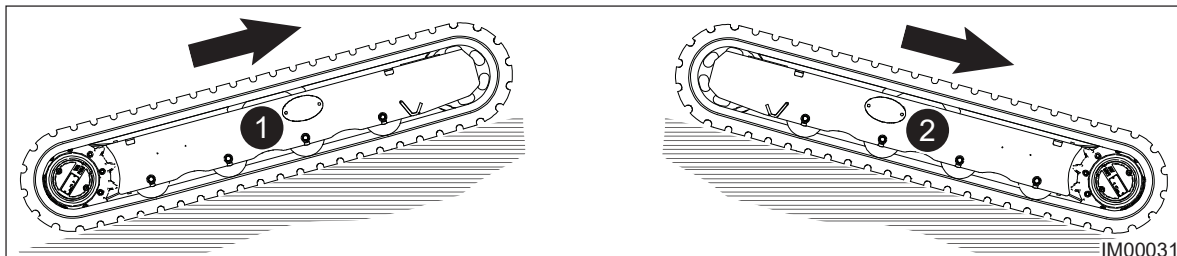

Fig: 6.1 - Tracking Gradient

- When traveling down a gradient (Item 2, Fig: 6.1), the tracks should be driven sprocket first.
- The machine can not and shall not be maneuvered sideways across a slope.
- Ensure the machine is positioned on level ground for operation. Do not put the machine into operation on a gradient.
- Ensure no leakage of oil from gearbox, roller and idler before and during tracking.
- Do not attempt to maneuver the machine if there is any build-up of material around the tracks or drive sprockets.
- Do not attempt to maneuver the machine if the tracks are frozen to the ground.
- Do not push or tow the machine if it is unable to free itself.
- When tracking for 10 minutes, stop tracking and allow 30 minutes for the track gearboxes to cool down.
- When tracking, monitor the hydraulic oil temperature and ensure it does not overheat.

(3) Crawler Track Working Conditions

Avoid using the rubber tracks in the following situations:

- Do not use in marine and seaside environments. Saline air will cause the rubber and the internal steel cords to lose adhesion.
- Do not keep the tracks in exposed sunlight for extended periods of time as UV rays will shorten the life of the rubber track.
- Avoid spilling fuels and synthetic oils on the rubber tracks, if this occurs, wash off immediately to prevent corrosion and unnecessary damage to the system.
- Avoid rubber track contact with sharp edges, particularly sharp concrete edges. This point loads the track and can cause damage to the internal steel cords in the belt.
- Rubber track systems are designed to be used on smooth soft ground.
- Do not attempt to track over obstacles which are taller than the centre line of the idler (Fig: 6.2).

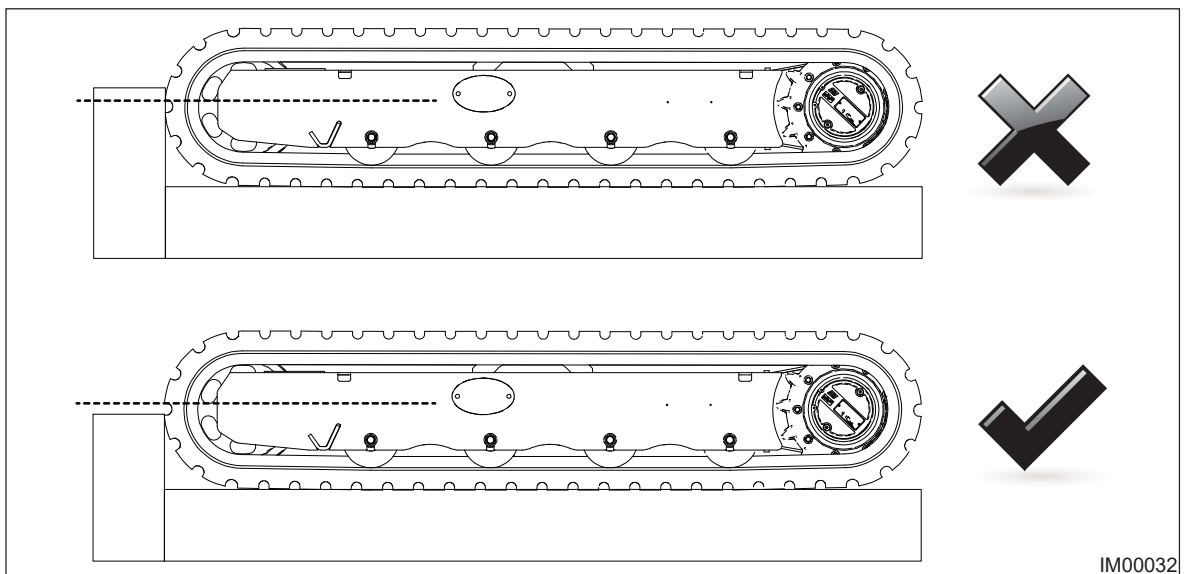

Fig: 6.2 - Tracking Obstacles

6.2 Maneuvering With Umbilical Handset

CAUTION

When possible, and if installed, use the radio remote control handset to obtain maximum distance from the machine when maneuvering. When using the umbilical handset extra caution shall be taken to avoid any potential hazards due to the restrictions of the cable.

PROCEDURE

1. Observe all safety warnings.
2. Inspect the umbilical handset and cable and ensure it is in good working order.
3. Familiarise with the operation of the umbilical handset (Fig: 6.3), direction of travel, and safe tracking instructions prior to attempting to maneuver this machine.

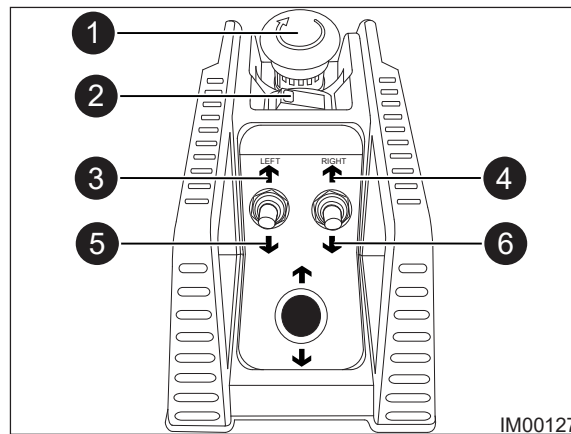

Fig: 6.3 - Umbilical Handset

Item	Function
1	Engine Stop Button
2	Handset ON/OFF Switch
3	Left Track Forward
4	Right Track Forward
5	Left Track Reverse
6	Right Track Reverse

4. Connect the umbilical lead to the plug socket located on the side of the engine compartment (Fig: 6.4) and secure.

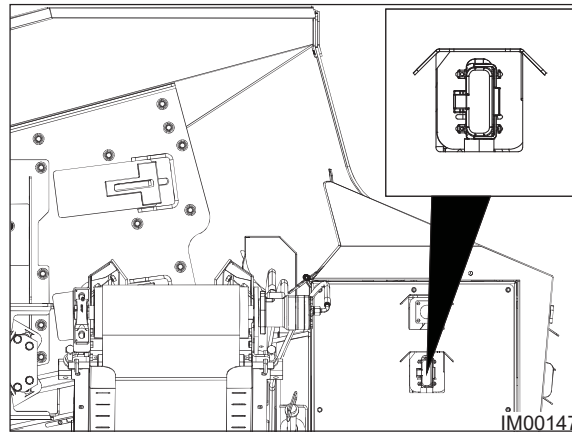

Fig. 6.4 - Umbilical Plug Socket

5. Follow the procedure to start the engine.
6. Rotate the Track Switch Counter-Clockwise to the Umbilical Handset position (Item 1, Fig: 6.5).

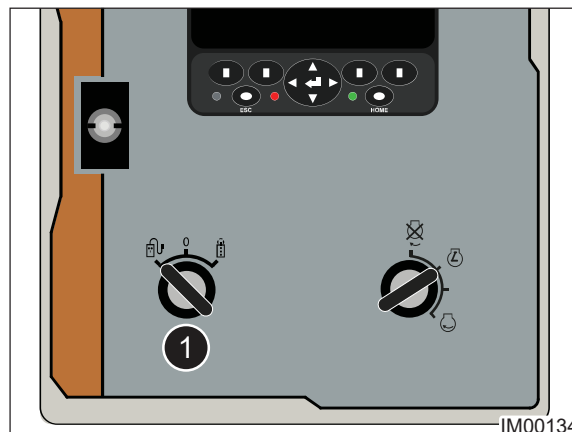

Fig. 6.5 - Track Switch - Umbilical Position

7. Turn ON the Umbilical Handset by pressing the Switch (Item 2, Fig: 6.3).
 - ◇ The control panel identifies the handset is connected and the Track Screen displays (Fig: 6.6).

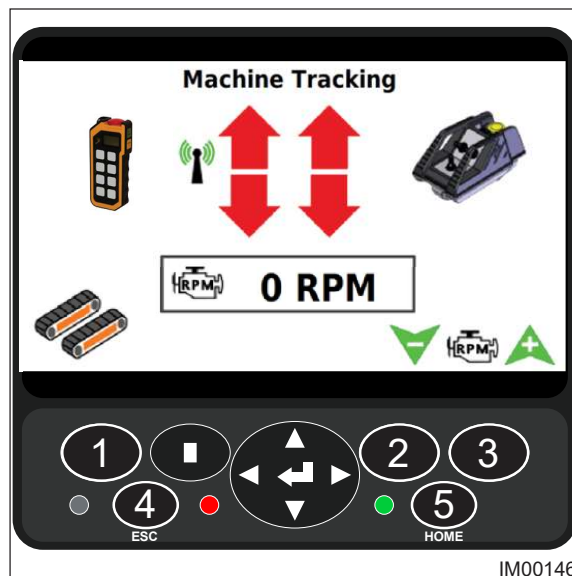

Fig. 6.6 - Track Screen

8. Press the Tracks Enable button (Item 1, Fig: 6.6).
 - ◇ *The Track Symbol above the button will flash orange and the siren will sound to indicate tracking is about to start. After the warning delay the tracks symbol will turn green and user can maneuver the machine. The siren will continue to sound while tracking is live.*
9. The Engine RPM can be increased and decreased using buttons (Items 2 & 3, Fig: 6.6).
10. Pressing the push buttons on the umbilical handset will make the machine move. Refer to "Umbilical Handset - Direction Of Travel" on page 6-9.
 - ◇ *The arrows on the display will change from red to green when movement is requested to provide feedback.*
11. When finished maneuvering:
 - Push the Handset Off switch (Item 2, Fig: 6.3).
 - Press the Tracks Disable button (Item 1, Fig: 6.6) on the Display Screen.
 - Rotate the Track Switch (Item 1, Fig: 6.5) to the Off / Neutral position.

(1) Umbilical Handset - Direction Of Travel

NOTICE

The operator shall fully understand the directional output from button presses on the umbilical handset. Misuse of the handset can result in damage to the machine and other equipment surrounding it. The button press sequences below (Fig: 6.7) illustrate the corresponding directional output.

Always pay attention when maneuvering. Ensure no personnel are near or around the machine.

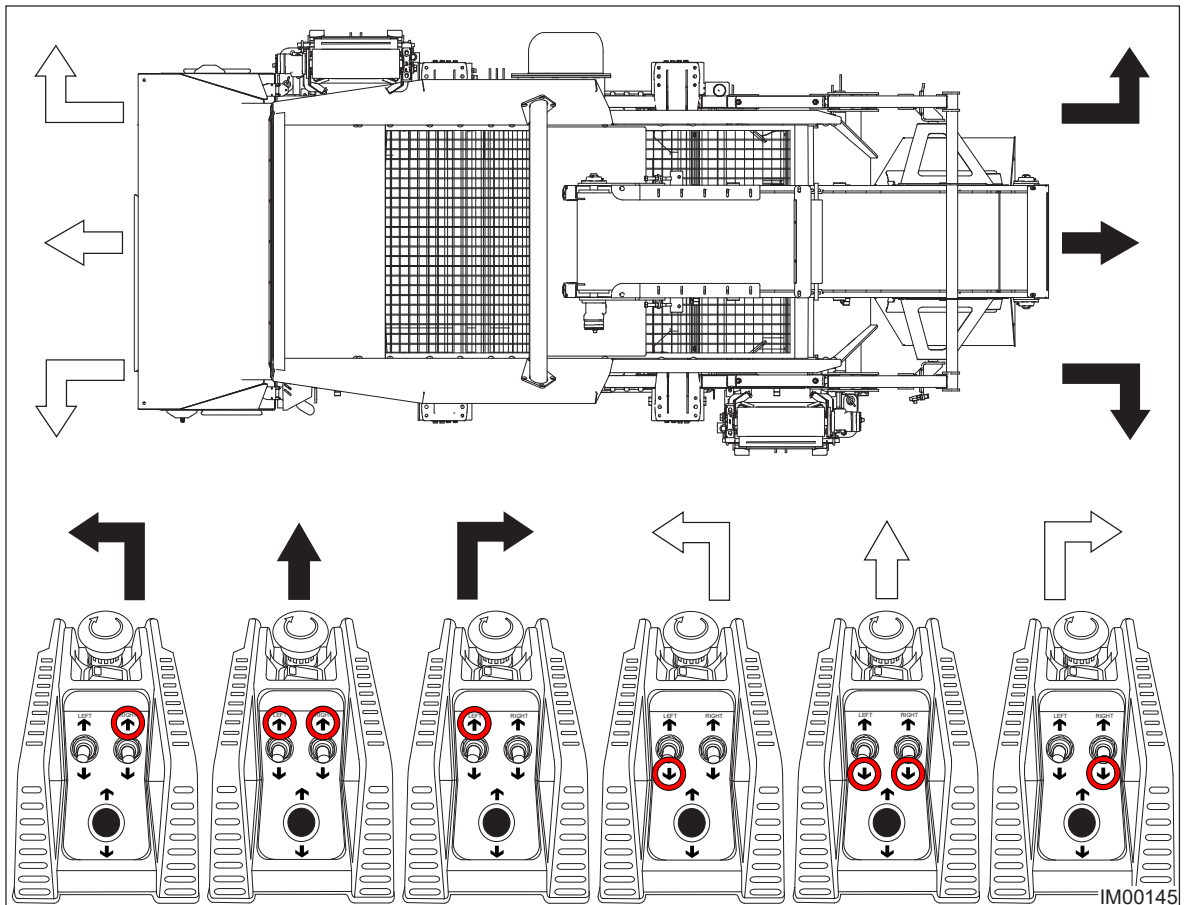

Fig: 6.7 - Umbilical Handset Directions

6.3 Maneuvering With Radio Remote Handset

NOTICE

The radio remote control handset is the safest method for maneuvering the machine. It allows the operator to move the machine without the restriction of a cable and also provides more visibility around the machine to avoid potential hazards.

PROCEDURE

1. Observe all safety warnings.
2. Install (if not already) a charged battery to the remote control handset.
3. Inspect the radio remote handset and ensure it is in good working order.
4. Familiarise with the operation of the radio remote handset (Fig: 6.8), direction of travel, and safe tracking instructions prior to attempting to maneuver this machine.

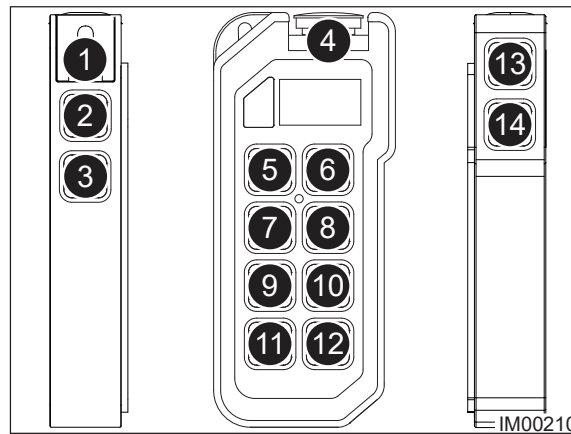

Fig: 6.8 - Radio Remote Handset

Item	Function
1	Mode Switch (Screener/Off/Tracks)
2	Both Tracks Forward
3	Both Tracks Reverse
4	Engine Stop Button
5	Left Track Forward
6	Right Track Forward
7	Left Track Reverse
8	Right Track Reverse
9	Manual - Oversize & Middle Grade Conveyor Start/Stop
10	Manual - Collection & Fines Conveyor Start/Stop
11	Manual - Vibrating Screen Box Start/Stop
12	Activate Tracks
13	Activate Remote
14	Activate Auto Run

5. Obtain the over-ride plug and insert it into the plug socket located on the side of the engine compartment (Fig: 6.9) and secure.

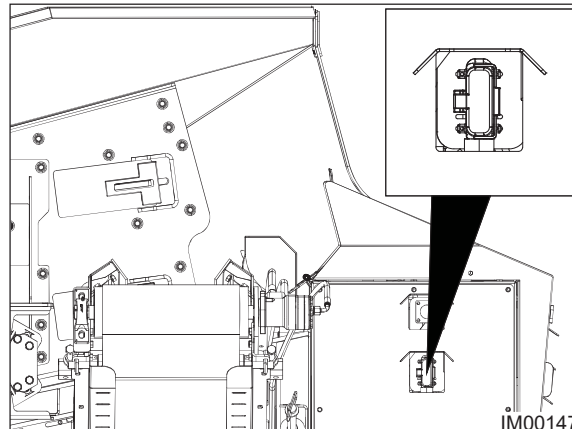

Fig: 6.9 - Umbilical Plug Socket

6. Follow the procedure to start the engine.
7. Rotate the Track Switch Clockwise to the Radio Remote Handset position (Item 1, Fig: 6.10).

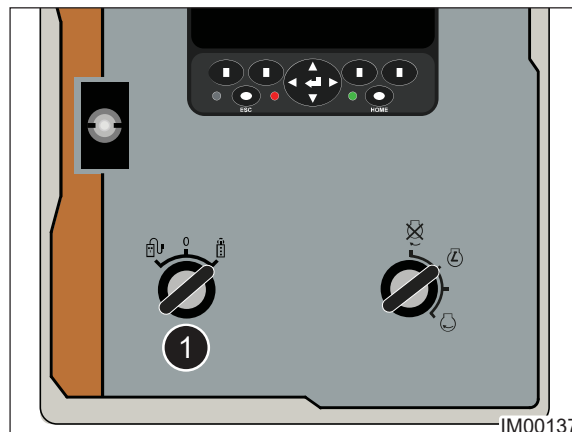

Fig: 6.10 - Track Switch - Radio Remote Position

8. On the radio remote handset, place Mode Switch to the right, Track position (Item 1, Fig: 6.8).
9. Turn on the radio remote control by pressing the Green Activate Handset button (Item 13, Fig: 6.8).
 - ◇ The control panel identifies the handset is connected and the Track Screen displays (Fig: 6.11).

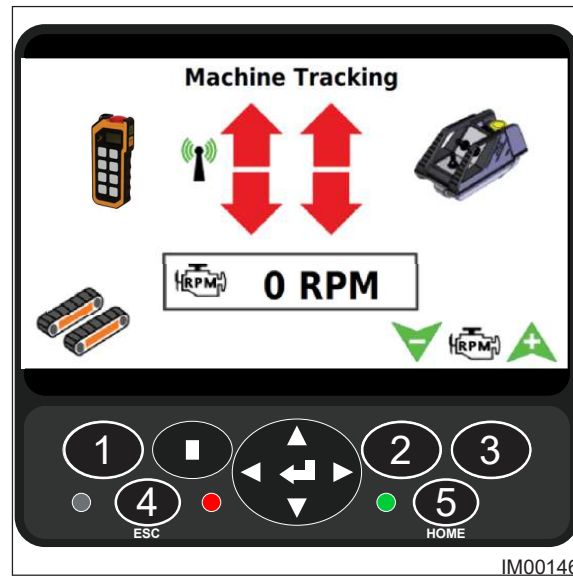

Fig: 6.11 - Track Screen

10. Press the Tracks Enable button on the remote handset (Item 12, Fig: 6.8) or on the control panel (Item 1, Fig: 6.11).
 - ◇ *The Track Symbol above the button (Item 1, Fig: 6.11) will flash orange and the siren will sound to indicate tracking is about to start. After the warning delay the track symbol will change to green and user can maneuver the machine. The siren will continue to sound when tracking is enabled.*
11. Pressing the push buttons on the radio remote handset will maneuver the machine. Refer to "Radio Remote Handset - Direction Of Travel" on page 6-13 for the machine directions.
 - ◇ *The arrows on the display will change from red to green when movement is requested to provide feedback.*
12. Pressing the Red Stop button (Item 4, Fig: 6.8), stops the engine.
13. When finished maneuvering:
 - Push the Power Off button (Item 13, Fig: 6.8) on the Remote Handset.
 - Press the Tracks Disable button (Item 1, Fig: 6.11) on the display screen.
 - Rotate the Track Switch (Item 1, Fig: 6.10) to the Off / Neutral position.
 - Place the Toggle Switch (Item 1, Fig: 6.8) to the Off position.
 - Switch off the Remote Handset by pressing the Red Stop button (Item 4, Fig: 6.8).

(1) Radio Remote Handset - Direction Of Travel

NOTICE

The operator shall fully understand the directional output from button presses on the radio remote handset. Misuse of the handset can result in damage to the machine and other equipment surrounding it. The button press sequences below (Fig: 6.12) illustrate the corresponding directional output.

Always pay attention when maneuvering. Ensure no personnel are near or around the machine.

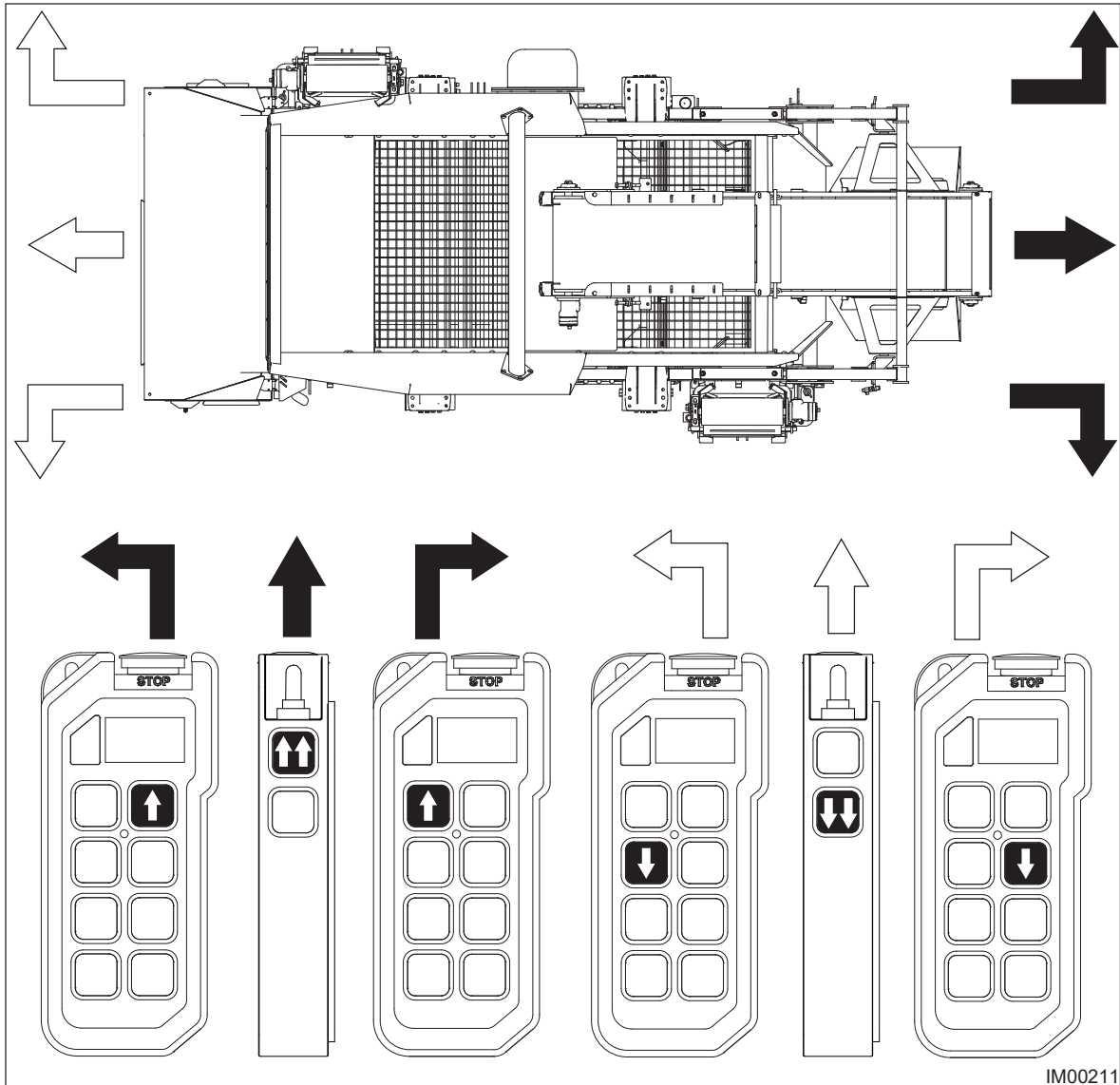

Fig: 6.12 - Umbilical Handset Directions

Intentionally Left Blank.

Table of Content

7	Machine Setup.....	7-2
7.1	Safety Prior To & During Setup.....	7-3
	(1) Prior To Setup	7-3
	(2) During Setup	7-3
	(3) Setup Measures After Long Term Standstill.....	7-4
	(4) Setup Sequence	7-4
7.2	Setting Up The Machine	7-5
	(1) Task 1 - Remove Machine From The Transporter	7-5
	(2) Task 2 - Position The Machine.....	7-6
	(3) Task 3 - Activate Hydraulic System.....	7-7
	(4) Task 4 - Unfold The Oversize Conveyor	7-8
	(5) Task 5 - Unfold The Mid-Size Conveyor	7-10
	(6) Task 6 - Unfold The Fines-Size Conveyor	7-12

7 Machine Setup

DANGER

Crush Hazard.

Death or serious injury will result from contact with the crawler tracks when moving.

Keep clear of crawler tracks when the machine is maneuvering.

Electrocution Hazard.

Death or injury will result from contacting electric power lines.

Be aware of overhead power lines and cables routed along the ground when folding or moving the machine.

Always maintain the required clearance.

Always contact the electric power line owner if cables or power lines require to be disconnected. The electric supply shall be disconnected or the power lines moved or insulated prior to performing machine operations.

WARNING

Injection Hazard.

Escaping fluid under pressure can penetrate skin and result in death or serious injury. Relieve pressure before disconnecting hydraulic lines.

Keep away from leaks and pin holes. Use a piece of cardboard or paper to search for leaks. Do not use hand. Fluid injected into the skin must be surgically removed within a few hours by a doctor familiar with this type of injury, or gangrene will result.

Crush Hazard.

Stay clear of moving conveyors to prevent serious injury or death.

Ensure all personnel are clear of the machine when operating components.

Nip Point Hazard.

Nip points exist at conveyor pivot points.

Contact with pivot points can result in serious injury or death.

Fall Hazard.

It is a requirement for the use of an EN/ANSI safety harness when working above specific heights. Check with your local law and regulations authority for the specific height requirements.

Wear Personal Protective Equipment.

Personal Protective Equipment (PPE) must be worn at all times.

CAUTION

Caution shall be taken when setting up this machine. A thorough risk assessment shall be carried out prior to setting up the machine and all safety hazards addressed.

Only experienced and trained operators, familiar with this type of equipment are permitted to operate this machine.

The operator shall read and understand the full content of this handbook prior to starting the engine or performing any operating procedures.

7.1 Safety Prior To & During Setup

NOTICE

Prior to setting up the machine, consideration shall be given to a suitable layout to prevent oversize material or metal from entering the machine. In order to prevent damage of the screen-unit no material above the size recommended shall be fed into it.

The environment in which the machine will operate contains inherent health and safety risks, which the operator shall take the necessary steps to avoid.

Dangers from overhead conveyors discharges, over-spill material, vehicle movements, etc; as well as other site related hazards shall be anticipated. Avoid these by performing risk assessments prior to the machine being put into operation and ensure appropriate exclusion zone measures are put in place and site personnel safety awareness training has been undertaken.

(1) Prior To Setup

PROCEDURE

1. Observe all safety warnings.
2. Ensure the machine is locked and tagged out.
3. Inspect all safety guards and devices are installed and positioned correctly.
4. Remove all loose items that have been transported with the machine.
5. Test the hydraulic control valve levers, ensure they move freely and return to their neutral/non-operational position when released or placed into position.
6. Inspect the machine to ensure there are no loose or leaking hydraulic hoses.
7. Check all machine fluids are at the correct recommended levels.
8. Perform the 10 hour/daily maintenance schedule.
9. Ensure that the chosen site is level. If required, level the work site foundation with the loading shovel.

(2) During Setup

PROCEDURE

1. Observe all safety warnings.
2. Ensure the machine is placed on solid ground capable of carrying it's weight.
3. Level the machine with a precision spirit level.
4. Do not position the machine above ground level, e.g. on blocks etc.
5. Place the machine in a safe operating position ensuring both tracks are in full contact with the ground to minimise movement of the machine. Check the machine regularly to ensure it remains level and stable.
6. Pay attention to access from the loading area and to where material is to be deposited.
7. Ensure the area under the tail drum of each conveyor is free of large stones etc, which may cause damage to the belt.
8. Once the machine is setup, implement the recommended exclusion zone ("Exclusion Zone During Operation" on page 2-21).

(3) Setup Measures After Long Term Standstill**PROCEDURE**

1. Observe all safety warnings.
2. Ensure the machine is locked and tagged out.
3. Inspect all safety guards and devices are installed and positioned correctly.
4. Inspect the crawler tracks prior to transporting or moving the machine. Ensure crawler tracks are clear of any obstructions and have not seized.
5. If necessary wash the machine to remove all dirt and debris prior to transporting. Ensure no material or items can fall off the machine during transport.
6. Perform daily (10 hour) maintenance schedule.

(4) Setup Sequence**NOTICE**

To setup the machine correctly and prevent any damage to the equipment, the following tasks shall be performed in the given sequence.

PROCEDURE

1. "Task 1 - Remove Machine From The Transporter" on page 7-5.
2. "Task 2 - Position The Machine" on page 7-6.
3. "Task 3 - Activate Hydraulic System" on page 7-7
4. "Task 4 - Unfold The Oversize Conveyor" on page 7-8.
5. "Task 5 - Unfold The Mid-Size Conveyor" on page 7-10.
6. "Task 6 - Unfold The Fines-Size Conveyor" on page 7-12.

7.2 Setting Up The Machine

SAFETY INSTRUCTION

Setup of the machine requires two people to be present at all times. Do not setup this machine alone.

(1) Task 1 - Remove Machine From The Transporter

⚠ DANGER

Crush Hazard.

Death or serious injury will result from contact with the crawler tracks when moving.

Keep clear of crawler tracks when the machine is maneuvering.

NOTICE

The radio remote control handset is the safest method for maneuvering the machine. It allows the operator to move the machine without the restriction of a cable and also provides more visibility around the machine to avoid potential hazards.

It is the responsibility of the haulage contractor to remove the machine from the transporter.

PROCEDURE

1. Observe all safety warnings.
2. Prepare the machine to be removed from the transporter. Understand all tracking instructions prior to maneuvering ("Maneuvering The Machine" on page 6-2).
3. Ensure the ground is level and able to support the weight of the machine.
4. Start the engine.
5. Stand at a safe distance while maintaining good visibility around the machine.
6. Slow and carefully remove the machine from the transporter (Fig: 7.1).

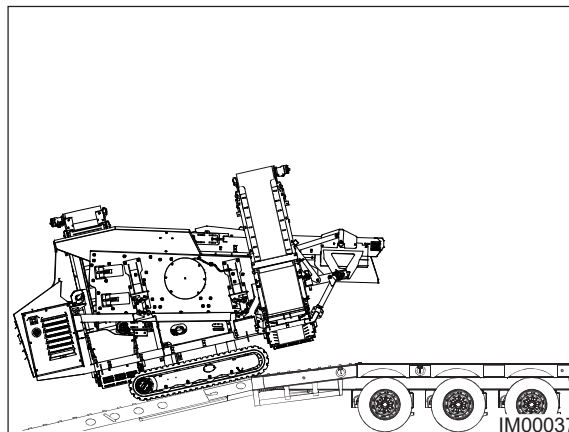

Fig: 7.1 - Transporter

7. Ensure the machine does not collide with the ground when maneuvering.

(2) Task 2 - Position The Machine**PROCEDURE**

1. Observe all safety warnings.
2. Prior to positioning the machine, ensure the working site surface is level and has sufficient space around it to allow for exclusion zones.
3. Ensure the surface on which the machine will be put into operation on, is solid and be capable of withholding the weight of the machine when fully loaded with material.
4. Maneuver the machine to the working location.
5. Ensure the machine is level and stable when positioned. The machine is fitted with a vibrating unit which could vibrate excessively or the machine could rock, causing damage or injury. Ensure that the full length and width of the crawler tracks are positioned firmly on the ground.
6. Use a spirit level (Fig: 7.2) to ensure that the machine is level across its width (Item 1) and length (Item 2).

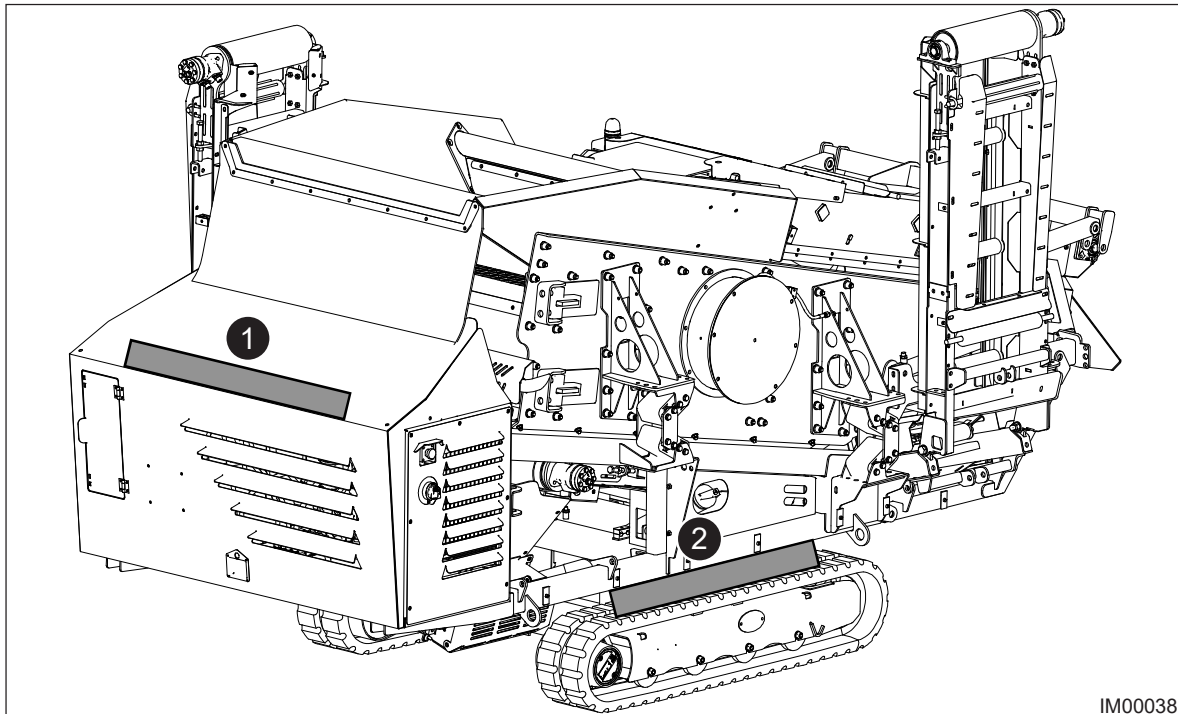

Fig: 7.2 - Levelling The Machine

7. Once the machine is positioned correctly, it can then be unfolded into the working position.
8. If the umbilical handset was used to maneuver the machine, disconnect it, and store away in a safe location.

(3) Task 3 - Activate Hydraulic System**NOTICE**

The machines hydraulic system requires to be activated to enable the operator to use the hydraulic control levers located on the machine.

PROCEDURE

1. Observe all safety warnings.
2. Follow the procedure to start the engine.
3. On the Home Screen (Fig: 7.3), press the Activate Hydraulic System button (Item 4).

◇ *The hydraulic system will become live and the control levers can now be operated.*

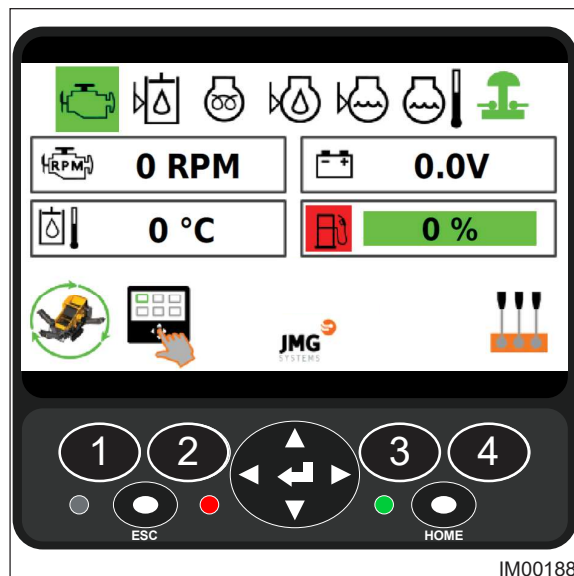

Fig: 7.3 - Home Screen

IM00188

(4) Task 4 - Unfold The Oversize Conveyor**PROCEDURE**

1. Observe all safety warnings.
2. Activate the hydraulic system ("Task 3 - Activate Hydraulic System" on page 7-7).
3. Proceed to the control levers located on the left-hand side of the machine (Fig: 7.4).

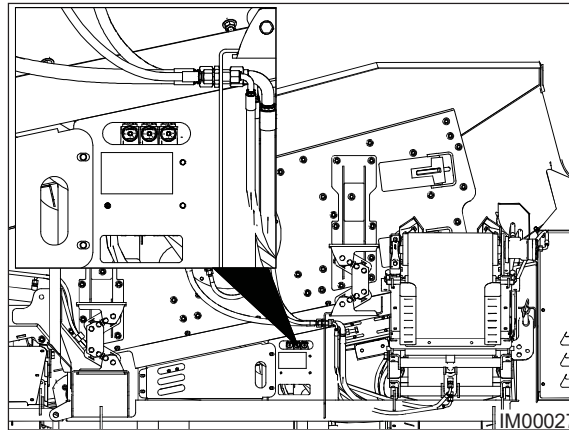

Fig: 7.4 - Control Levers

4. Slow and carefully push DOWN the Control Lever (Item 1, Fig: 7.5) to unfold the oversize conveyor.

◇ Observe the conveyor belt when unfolding. Adjust the belt position if necessary to prevent nips or tears, and ensure even positioning of the belt on the drive drum.

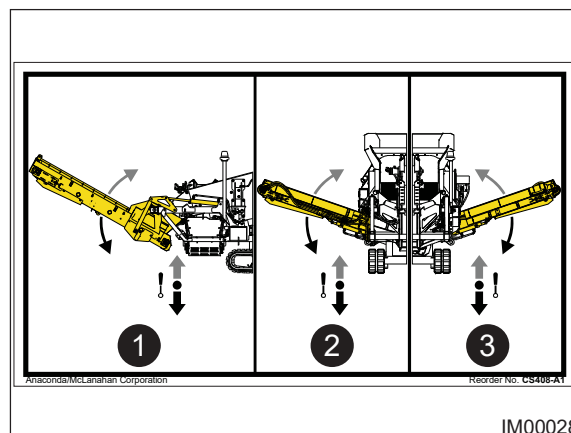

Fig: 7.5 - Control Levers

5. Once the conveyor has reached the Working Position (Fig: 7.6), release the control lever.

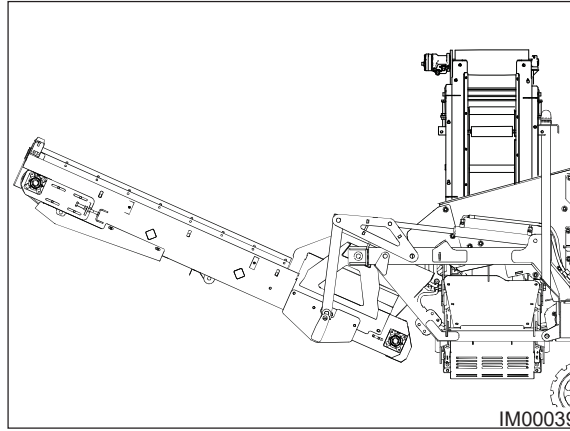

Fig: 7.6 - Oversize Conveyor Working Position

(5) Task 5 - Unfold The Mid-Size Conveyor**PROCEDURE**

1. Observe all safety warnings.
2. Remove the Transport Pin (Fig: 7.7).

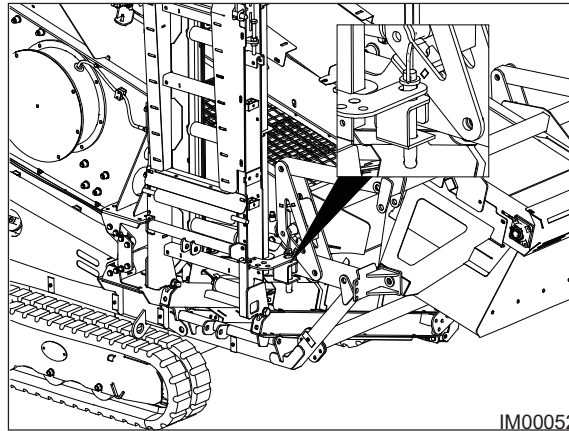

Fig: 7.7 - Transport Pin

3. Activate the hydraulic system ("Task 3 - Activate Hydraulic System" on page 7-7).
4. Proceed to the control levers located on the left-hand side of the machine (Fig: 7.8).

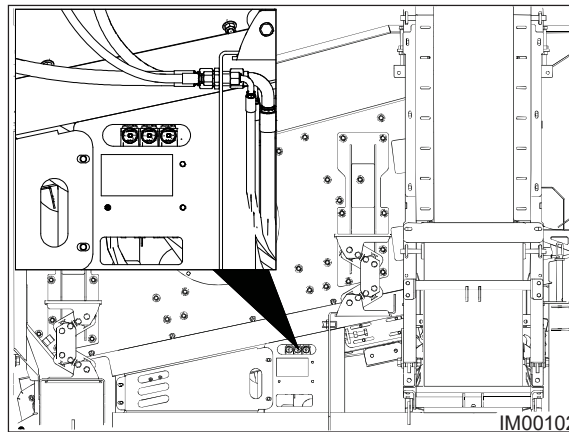

Fig: 7.8 - Control Levers

5. Slow and carefully push **DOWN** the Control Lever (Item 2, Fig: 7.9) to unfold the mid-size conveyor.

◇ *Observe the conveyor belt when unfolding. Adjust the belt position if necessary to prevent nips or tears, and ensure even positioning of the belt on the drive drum.*

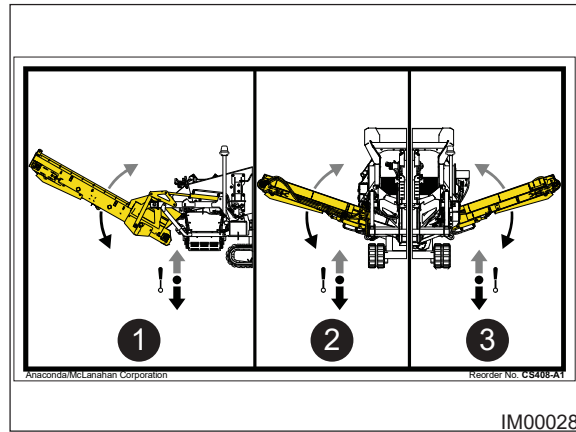

Fig: 7.9 - Control Levers

6. Once the conveyor has reached the Working Position (Fig: 7.10), release the control lever.

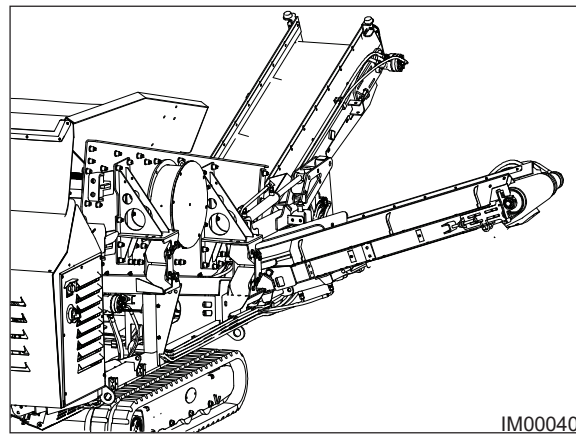

Fig: 7.10 - Mid-Size Conveyor Working Position

(6) Task 6 - Unfold The Fines-Size Conveyor**PROCEDURE**

1. Observe all safety warnings.
2. Remove the transport pin (Fig: 7.11).

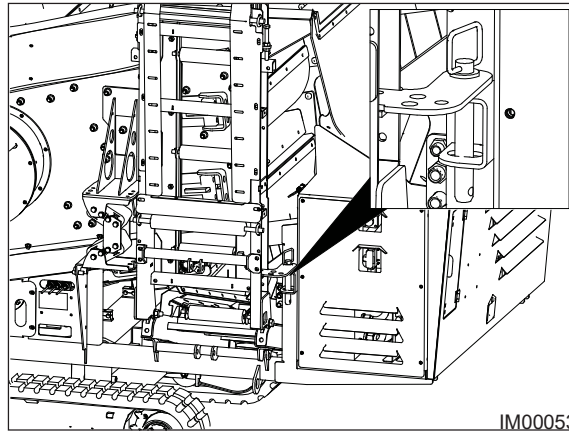

Fig: 7.11 - Transport Pin

3. Activate the hydraulic system ("Task 3 - Activate Hydraulic System" on page 7-7).
4. Proceed to the control levers located on the left-hand side of the machine (Fig: 7.12).

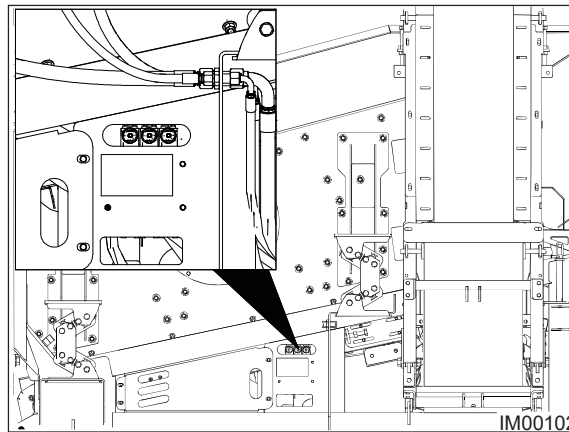

Fig: 7.12 - Control Levers

5. Slow and carefully push **DOWN** the Control Lever (Item 3, Fig: 7.13) to unfold the fines size conveyor.

◇ *Observe the conveyor belt when unfolding. Adjust the belt position if necessary to prevent nips or tears, and ensure even positioning of the belt on the drive drum.*

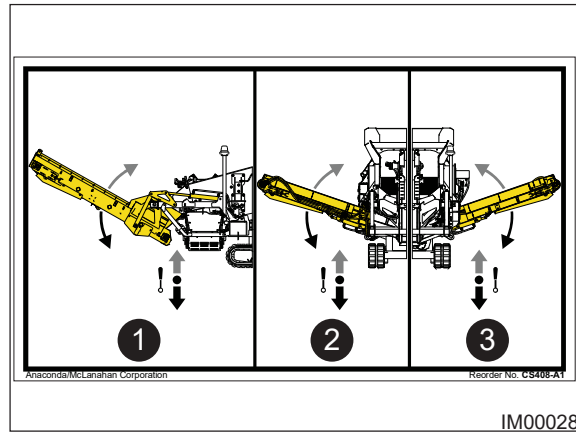

Fig: 7.13 - Control Levers

6. Once the conveyor has reached the Working Position (Fig: 7.14), release the control lever.

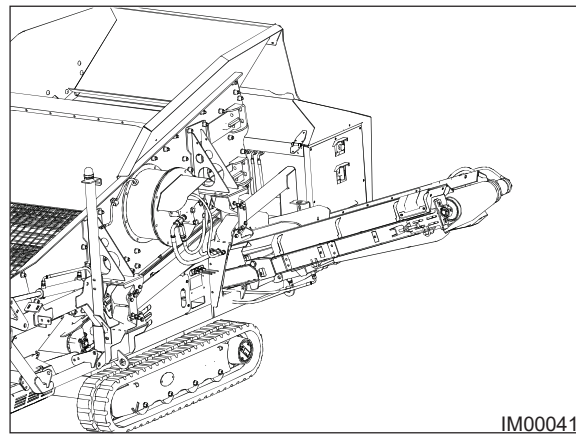

Fig: 7.14 - Fines Size Conveyor Working Position

Intentionally Left Blank.

Table of Content

8	Machine Operation.....	8-2
8.1	Checks Prior To Operating.....	8-3
8.2	Putting The Machine Into Operation	8-4
(1)	Auto Run Mode.....	8-4
(a)	Control Panel.....	8-4
(b)	Remote Control Operation	8-6
(2)	Manual Mode	8-9
(a)	Control Panel.....	8-9
(b)	Remote Control Operation	8-11

8 Machine Operation

DANGER

Entanglement Hazard.

Contact with moving conveyor belts will result in serious injury or death.

Stay clear of moving conveyor belts.

Do not operate this machine without all guards and covers in place.

Switch off, lock, and tag out prior to adjusting or servicing the machine.

WARNING

Injection Hazard.

Escaping fluid under pressure can penetrate skin and result in death or serious injury.

Relieve pressure before disconnecting hydraulic lines.

Keep away from leaks and pin holes. Use a piece of cardboard or paper to search for leaks. Do not use hand.

Fluid injected into the skin must be surgically removed within a few hours by a doctor familiar with this type of injury, or gangrene will result.

Wear Personal Protective Equipment.

Personal Protective Equipment (PPE) must be worn at all times.

Falling Material Hazard.

Stay clear of the machine when operating. If struck by falling material, death or serious injury can result.

NOTICE

Only fully trained and authorised personnel shall be given permission to operate this machine.

This machine shall only be operated when the operator has read the full contents of this handbook and fully understands the safety instructions and procedures provided. Do not operate this machine if in doubt or uncertain. Injuries to personnel and damage to the machine can result.

Only operate the machine when all safety guards and devices are present and correctly fitted.

In the event of a malfunction, stop the machine immediately and implement the lock and tag out procedure.

Report the malfunction to the authority in charge.

Do not operate the machine until the malfunction has been rectified.

8.1 Checks Prior To Operating

NOTICE

Prior to placing the machine into operation, ensure that the following checks are performed. Failure to do so can result in substantial damage to the machine or injury to personnel.

PROCEDURE

1. Observe all safety warnings.
2. Ensure no personnel, objects or tools etc. are on the machine.
3. Ensure that all safety guards and devices are installed and working correctly.
4. Ensure the umbilical control unit has been disconnected and stowed away to prevent any damage.
5. If the machine is being used with other machinery, ensure that all down-stream machines have been tested and are functioning correctly.
6. Ensure that all hydraulic levers are in the neutral position.
7. Ensure the emergency stop buttons are released.
8. Ensure the fuel tank has been filled prior to operating.
9. Ensure the hydraulic oil level is satisfactory and top up if required.
10. Ensure the engine oil level is satisfactory and top up if required.
11. Ensure the radiator coolant level is satisfactory and top up if required.
12. Drain the fuel water separator if necessary.
13. Inspect the machine for oil or coolant leaks.
14. Ensure the radiator and hydraulic oil coolers are clean and free from dirt.
15. Perform a final check around the machine, ensure that no one is on or near the machine.
16. Prior to starting the engine, ensure all switches on the control panel are in the OFF or NEUTRAL position.

8.2 Putting The Machine Into Operation

NOTICE

The machine can be placed into operation using two methods:

- Auto Mode
- Manual

Auto or manual mode can be initiated via the control panel or optional radio remote handset.

The radio remote method is recommended. This will allow the operator to put the machine into operation while maintaining a safe distance.

(1) Auto Run Mode

(a) Control Panel

PROCEDURE

1. Observe all safety warnings.
2. Follow the procedure to start the engine.
3. Allow the machine to run on idle for 5 minutes. This allows the machine to reach a suitable operating temperature.
4. On the Home Screen (Fig: 8.1), press the machine operating button (Item 1).

◇ *The Machine Operating screen will display (Fig: 8.3).*

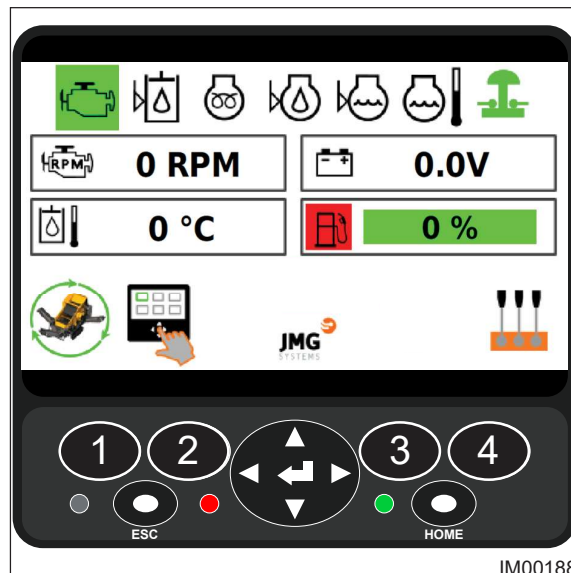

Fig: 8.1 - Home Screen

5. Using the Manual Throttle Lever (Fig: 8.2), increase the engine speed to maximum (2800 RPM).

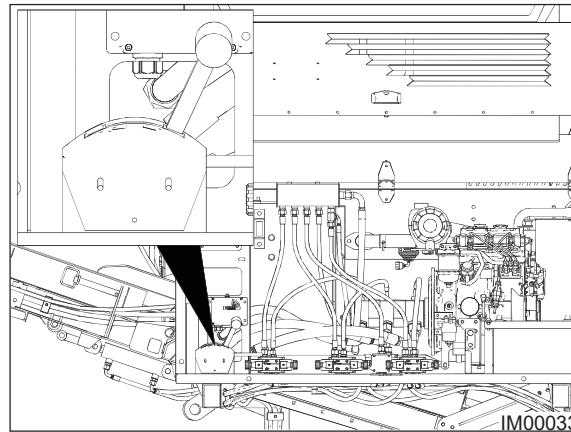

Fig: 8.2 - Throttle Lever

6. On the Machine Operating Screen (Fig: 8.3), press and hold the Auto Run button (Item 1) for 5 seconds.

◇ *The machine will begin the Auto Run sequence. The oversize & middle grade conveyors will start, followed by collection & fines conveyor. When the hydraulic oil temperature reaches 15°C (59°F), the vibrating screen box will start. Each component in operation, will display a green rotational circle.*

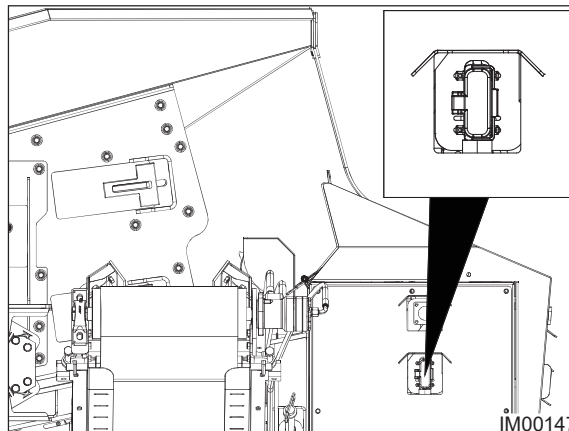

Fig: 8.3 - Machine Operating Screen

7. Perform a walk around inspection prior to loading material into the machine. Ensure conveyor belts are correctly tensioned and aligned.
8. After material has been loaded into the machine and fully processed, inspect the conveyor belts and perform any necessary adjustments that are required. Refer to: "Conveyor Maintenance" on page 11-42.

(b) Remote Control Operation**PROCEDURE**

1. Observe all safety warnings.
2. Ensure a fully charged battery has been installed in the radio remote control handset.
3. Obtain the over-ride plug and insert it into the plug socket located on the side of the engine compartment (Fig: 8.4) and secure.

*Fig: 8.4 - Umbilical Plug Socket*

4. Follow the procedure to start the engine.
5. Rotate the Track Switch clockwise to the Radio Remote Handset position (Item 1, Fig: 8.5).

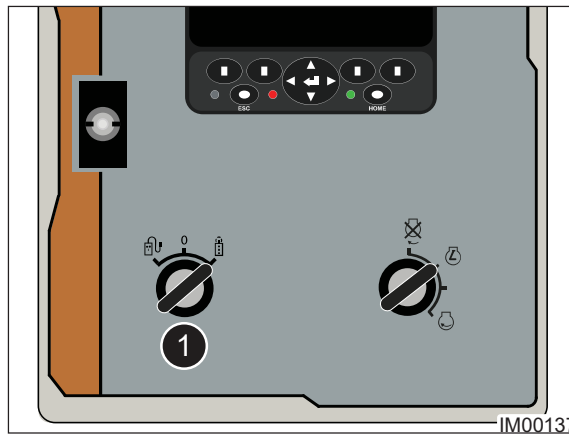
*Fig: 8.5 - Track Switch - Radio Remote Position*

6. On the radio remote handset, push the Toggle Switch (Item 1, Fig: 8.6) to the Left, Screener position.

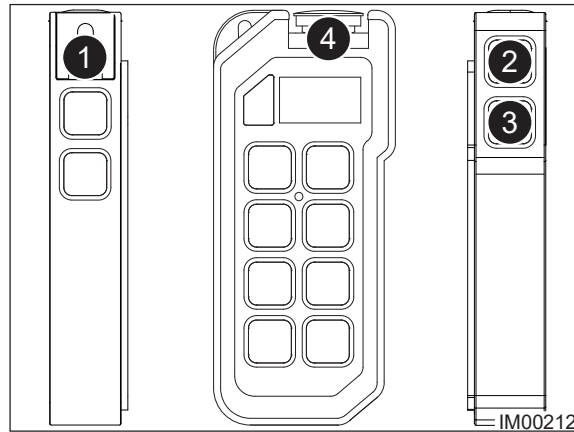

Fig: 8.6 - Radio Remote Handset

7. Turn on the remote control by pressing the Green Activate Handset button (Item 2, Fig: 8.6) on the side of the handset.
 - ◇ *The remote control handset will power-up.*
8. Press the Green Activate Handset button (Item 2, Fig: 8.6) a second time to activate the handset.
9. Using the Manual Throttle Lever (Fig: 8.7), increase the engine speed to maximum (2800 RPM).

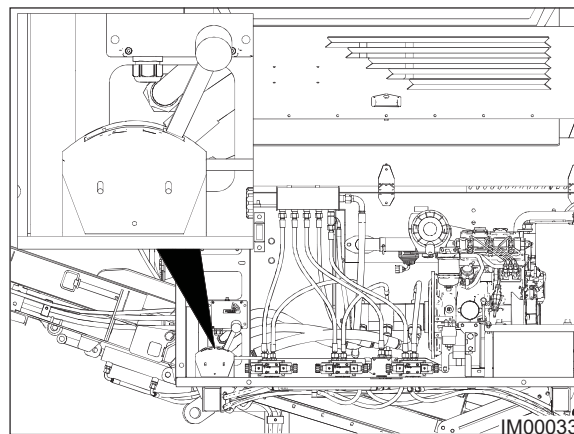

Fig: 8.7 - Throttle Lever

10. On the radio remote handset, press the Auto Run button (Item 3, Fig: 8.6).
 - ◇ *The machine will begin the Auto Run sequence. The oversize & middle grade conveyors will start, followed by collection & fines conveyor. When the hydraulic oil temperature reaches 15°C (59°F), the vibrating screen box will start. Each component in operation, will display a green rotational circle (Fig: 8.8).*

(2) Manual Mode**(a) Control Panel**

PROCEDURE

1. Observe all safety warnings.
2. Follow the procedure to start the engine.
3. Allow the machine to run on idle for 5 minutes. This allows the machine to reach a suitable operating temperature.
4. On the Home Screen (Fig: 8.9), press the Machine Operating button (Item 1).
 - ◇ *The Machine Operating screen will display (Fig: 8.11).*

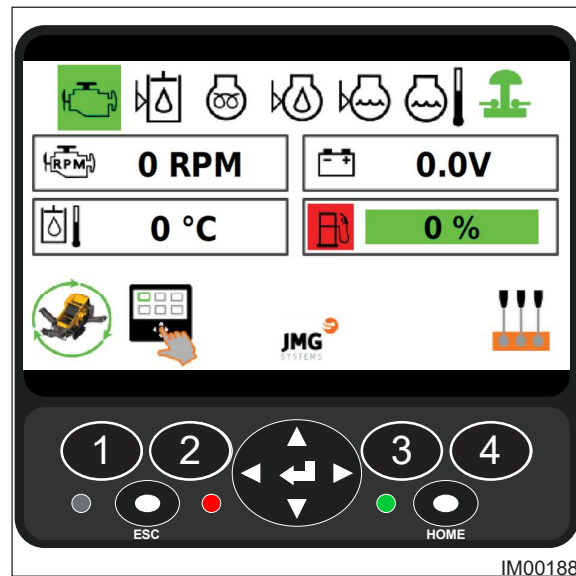

Fig: 8.9 - Home Screen

5. Using the Manual Throttle Lever (Fig: 8.10), increase the engine speed to maximum (2800 RPM).

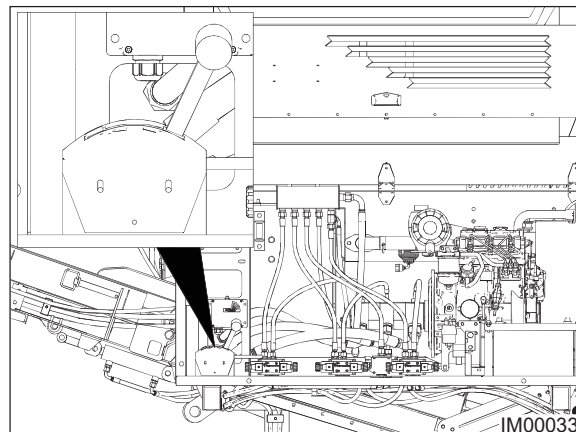

Fig: 8.10 - Throttle Lever

6. On the Machine Operating Screen (Fig: 8.11), press the Oversize & Middle Grade Conveyor Start button (Item 1).
 - ◇ *The oversize & middle grade conveyors will start.*



Fig: 8.11 - Machine Operating Screen

7. Press the Collection & Fines Conveyor Start button (Item 2, Fig: 8.11).
 - ◇ The collection & fines conveyors will start.
8. Observe the hydraulic oil temperature on the Machine Operating Screen (Fig: 8.11). When the hydraulic oil temperature reaches 15°C (59°F), press the Vibrating Screen Box Start button (Item 3).
 - ◇ The vibrating screen box will start.
9. Perform a walk around inspection prior to loading material into the machine. Ensure conveyor belts are correctly tensioned and aligned.
10. After material has been loaded into the machine and fully processed, inspect the conveyor belts and perform any necessary adjustments that are required. Refer to: "Conveyor Maintenance" on page 11-42.

(b) Remote Control Operation**PROCEDURE**

1. Observe all safety warnings.
2. Ensure a fully charged battery has been installed in the radio remote control handset.
3. Obtain the over-ride plug and insert it into the plug socket located on the side of the engine compartment (Fig: 8.12) and secure.

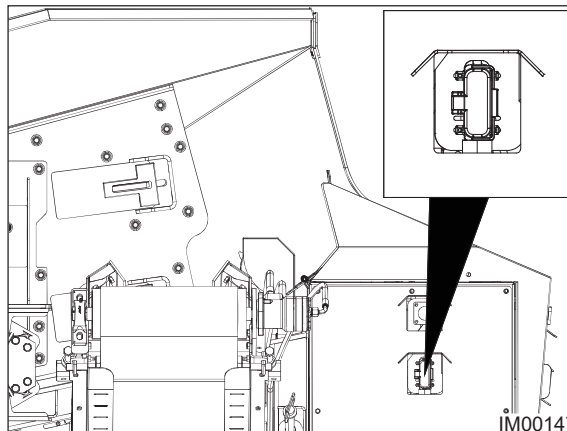

Fig: 8.12 - Umbilical Plug Socket

4. Follow the procedure to start the engine.
5. Rotate the Track Switch clockwise to the Radio Remote Handset position (Item 1, Fig: 8.13).

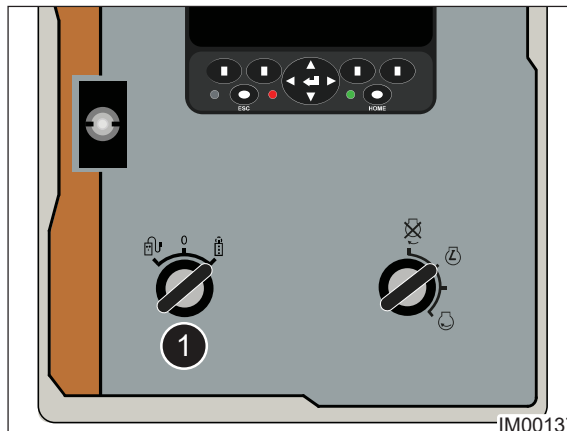

Fig: 8.13 - Track Switch - Radio Remote Position

6. On the radio remote handset, push the Toggle Switch (Item 1, Fig: 8.14) to the Left, Screener position.

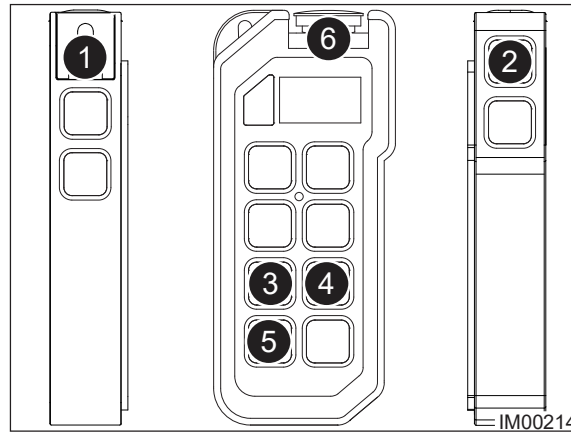

Fig: 8.14 - Radio Remote Handset

7. Turn on the remote control by pressing the Green Activate Handset button (Item 2, Fig: 8.14) on the side of the handset.
 - ◇ *The remote control handset will power-up.*
8. Press the Green Activate Handset button (Item 2, Fig: 8.14) a second time to activate the handset.
9. Using the Manual Throttle Lever (Fig: 8.15), increase the engine speed to maximum (2800 RPM).

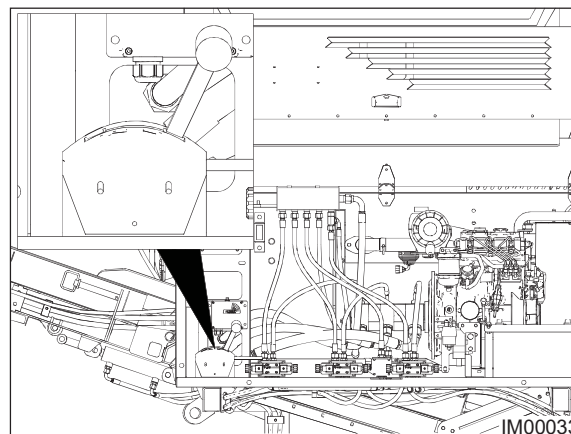

Fig: 8.15 - Throttle Lever

10. On the radio remote handset, press the Oversize & Middle Grade Conveyor Start button (Item 3, Fig: 8.14).
 - ◇ *The oversize & middle grade conveyors will start.*
11. Press the Collection & Fines Conveyor Start button (Item 4, Fig: 8.14).
 - ◇ *The oversize & middle grade conveyors will start.*
12. Observe the hydraulic oil temperature on the Machine Operating Screen (Fig: 8.16). When the hydraulic oil temperature reaches 15°C (59°F), press the Vibrating Screen Box Start button (Item 5, Fig: 8.14) on the radio remote handset.
 - ◇ *The vibrating screen box will start.*



Fig: 8.16 - Machine Operating Screen

Fig: 8.17 -

13. Perform a walk around inspection prior to loading material into the machine. Ensure conveyor belts are correctly tensioned and aligned.
14. After material has been loaded into the machine and fully processed, inspect the conveyor belts and perform any necessary adjustments that are required. Refer to: "Conveyor Maintenance" on page 11-42.
15. Pressing the Red Stop button (Item 6, Fig: 8.16) on the remote handset will stop the engine.

Intentionally Left Blank.

Table of Content

9	Machine Shut Down	9-2
9.1	Shutting Down The Machine	9-3
(1)	Auto Mode	9-3
(a)	Control Panel.....	9-3
(b)	Radio Remote	9-5
(2)	Manual Mode	9-7
(a)	Control Panel.....	9-7
(b)	Radio Remote	9-9
9.2	Emergency Shut Down	9-11
(1)	Restart After Emergency Stop	9-12

9 Machine Shut Down

DANGER

Entanglement Hazard.

Contact with moving conveyor belts will result in serious injury or death.

Stay clear of moving conveyor belts.

Do not operate this machine without all guards and covers in place.

Switch off, lock, and tag out prior to adjusting or servicing the machine.

WARNING

Injection Hazard.

Escaping fluid under pressure can penetrate skin and result in death or serious injury.

Relieve pressure before disconnecting hydraulic lines.

Keep away from leaks and pin holes. Use a piece of cardboard or paper to search for leaks. Do not use hand.

Fluid injected into the skin must be surgically removed within a few hours by a doctor familiar with this type of injury, or gangrene will result.

Wear Personal Protective Equipment.

Personal Protective Equipment (PPE) must be worn at all times.

Falling Material Hazard.

Stay clear of the machine when operating. If struck by falling material death or serious injury can result.

NOTICE

The shut down procedure can only be performed when all components have fully discharged all material. Never leave material in the machine. Starting the machine with material in it will cause performance issues and can damage to the equipment.

In the even of an emergency shut down, all material will require to be removed manually.

Only fully trained and authorised personnel shall be given permission to shut down this machine. The operator will have read and fully understood the contents of this handbook prior to performing any operational procedures.

9.1 Shutting Down The Machine

NOTICE

The machine can be shut down using two methods:

- Auto Mode
- Manual Mode

When in either mode the machine can be shut down via the control panel or the optional radio remote handset.

(1) Auto Mode

(a) Control Panel

PROCEDURE

1. Observe all safety warnings.
2. Ensure all material has been discharged and the machine is running empty.
3. On the Machine Operating Screen (Fig: 9.1), press the Auto Run button (Item 1).

◇ *The machine will begin the Auto Run shut down sequence. The vibrating screen box will stop first, then the collection & fines conveyors, followed by the oversize & middle grade conveyors.*



Fig: 9.1 - Machine Operating Screen

4. Using the Throttle (Fig: 9.2), reduce the engine speed to idle (950 RPM).

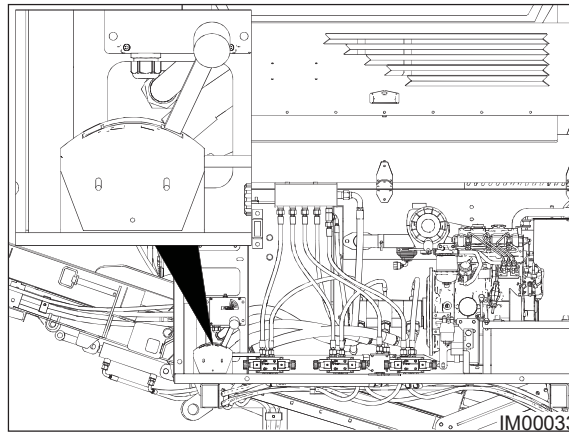

Fig: 9.2 - Throttle Lever

5. Rotate the ignition key (Item 1, Fig: 9.3) Counter-Clockwise to switch off the engine. Remove the key from the ignition and store in a safe location.

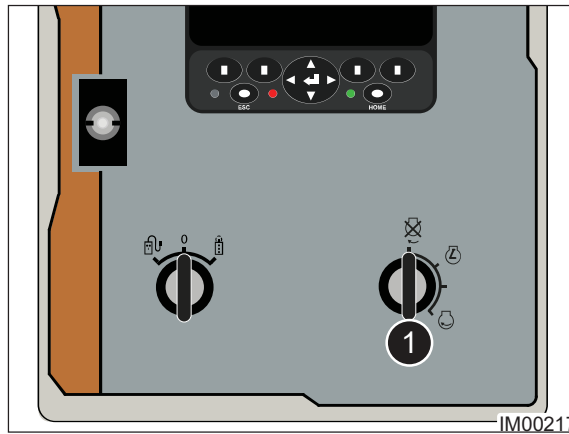

Fig: 9.3 - Ignition Key

6. Implement the lock and tag out ("Lock & Tag Out Procedure" on page 2-25).

(b) Radio Remote**PROCEDURE**

1. Observe all safety warnings.
2. Ensure all material has been discharged and the machine is running empty.
3. On the radio remote handset, press the Auto Run button (Item 1, Fig: 9.4).

◇ *The machine will begin the Auto Run shut down sequence. The vibrating screen box will stop first, then the collection & fines conveyors, followed by the oversize & middle grade conveyors.*

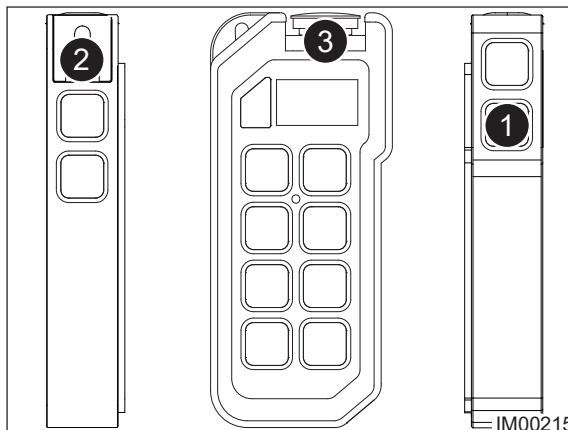

Fig: 9.4 - Radio Remote

4. Place the Toggle switch (Item 2, Fig: 9.4) in the middle, OFF position.
5. On the control panel, rotate the Handset Switch (Item 1, Fig: 9.5) to the Middle/Off position.

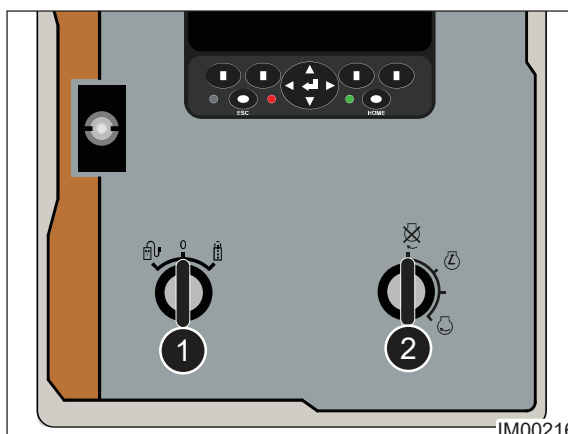

Fig: 9.5 - Control Panel

6. Turn off the radio remote handset by pressing the Red Stop button (Item 3, Fig: 9.4).
7. Using the Throttle (Fig: 9.6), reduce the engine speed to idle (950 RPM).

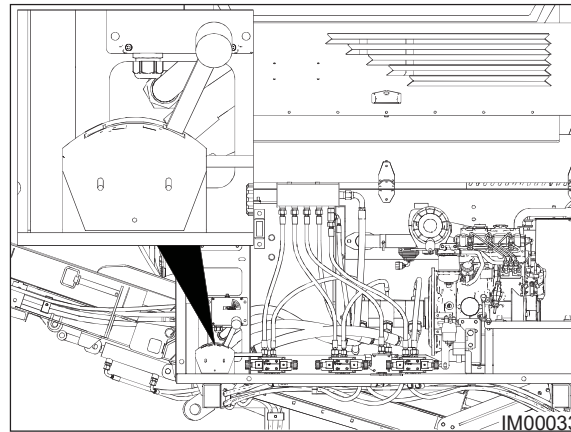

Fig: 9.6 - Throttle Lever

8. Rotate the ignition key (Item 2, Fig: 9.5) Counter-Clockwise to switch off the engine. Remove the key from the ignition and store in a safe location.
9. Implement the lock and tag out ("Lock & Tag Out Procedure" on page 2-25).
10. If required recharge the radio remote handset battery.

(2) Manual Mode**(a) Control Panel**

PROCEDURE

1. Observe all safety warnings.
2. Ensure all material has been discharged and the machine is running empty.
3. On the Machine Operating Screen, press the Vibrating Screen Box button (Item 1, Fig: 9.7).
 ◇ *The vibrating screen box will stop.*

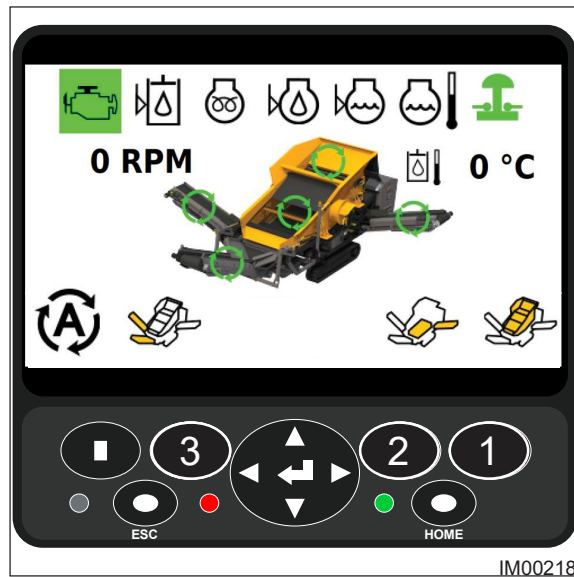

Fig: 9.7 - Machine Operating Screen

4. Press the Collection & Fines Conveyor button (Item 2, Fig: 9.7).
 ◇ *The collection & fines conveyors will stop.*
5. Press the Oversize & Middle Grade button (Item 3, Fig: 9.7).
 ◇ *The oversize & middle grade conveyors will stop.*
6. Using the Throttle (Fig: 9.8), reduce the engine speed to idle (950 RPM).

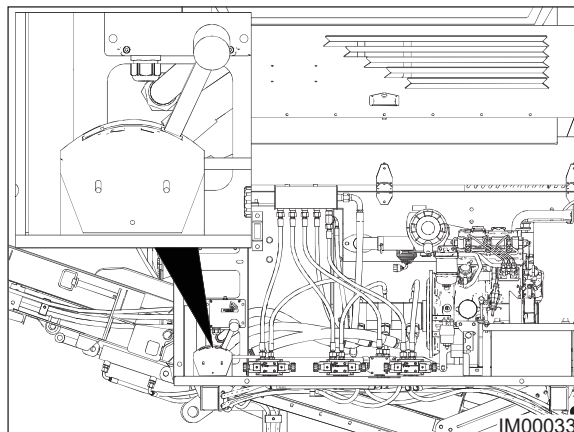

Fig: 9.8 - Throttle Lever

7. Rotate the Ignition Key (Item 1, Fig: 9.9) Counter-Clockwise to switch off the engine. Remove the key from the ignition and store in a safe location.

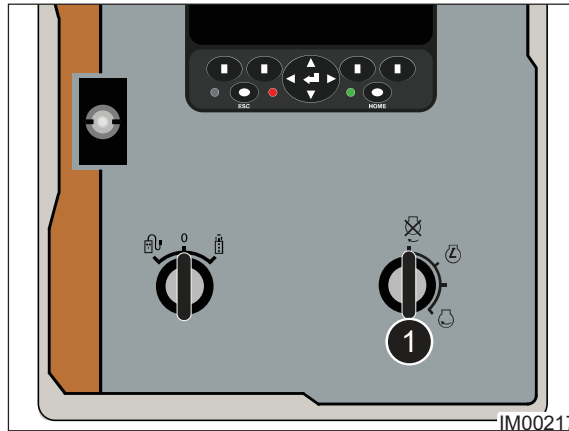

Fig: 9.9 - Ignition Key

8. Implement the lock and tag out ("Lock & Tag Out Procedure" on page 2-25).

(b) Radio Remote

PROCEDURE

1. Observe all safety warnings.
2. Ensure all material has been discharged and the machine is running empty.
3. On the radio remote handset, press the Vibrating Screen Box button (Item 1, Fig: 9.10).

◇ *The vibrating screen box will stop.*

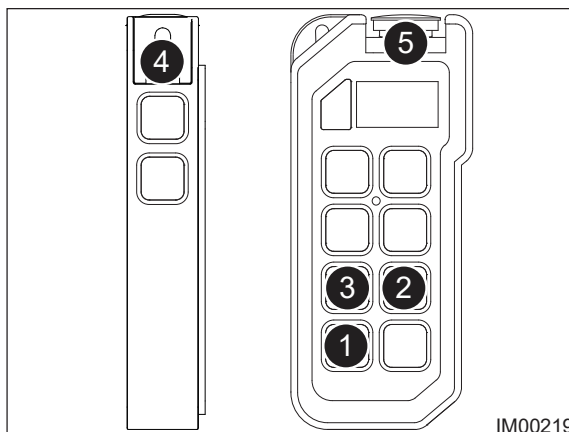

Fig: 9.10 - Radio Remote

4. Press the Collection & Fines Conveyor button (Item 2, Fig: 9.10).
 - ◇ *The collection & fines conveyors will stop.*
5. Press the Oversize & Middle Grade Conveyor button (Item 3, Fig: 9.10).
 - ◇ *The oversize & middle grade conveyors will stop.*
6. Place the Toggle switch (Item 4, Fig: 9.10) in the middle, Off position.
7. On the control panel, rotate the Handset Switch (Item 1, Fig: 9.11) to the Middle/Off position.

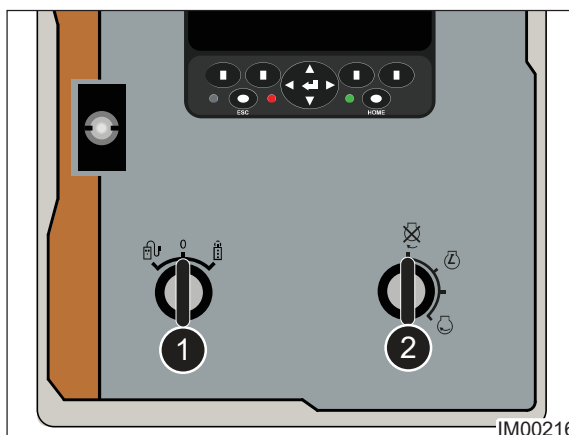

Fig: 9.11 - Control Panel

8. Turn off the radio remote handset by pressing the Red Stop button (Item 5, Fig: 9.10).
9. Using the Throttle (Fig: 9.12), reduce the engine speed to idle (950 RPM).

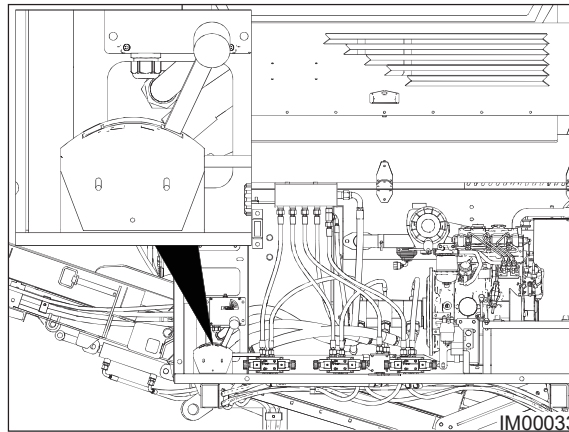

Fig: 9.12 - Throttle Lever

10. Rotate the ignition key (Item 2, Fig: 9.11) Counter-Clockwise to switch off the engine. Remove the key from the ignition and store in a safe location.
11. Implement the lock and tag out ("Lock & Tag Out Procedure" on page 2-25).
12. If required recharge the radio remote handset battery.

9.2 Emergency Shut Down

NOTICE

Emergency stop buttons are only to be used in the event of an emergency. Do not use an emergency stop button to shut down the machine in normal operation.

The engine stop button on the umbilical and radio remote handsets are not classified as an emergency stop. The handsets are not always connected to the machine.

When an emergency stop has been performed, all material in the machine will require to be manually removed.

PROCEDURE

1. Observe all safety warnings.
2. Engage (push in) the nearest emergency stop button (Fig: 9.13).

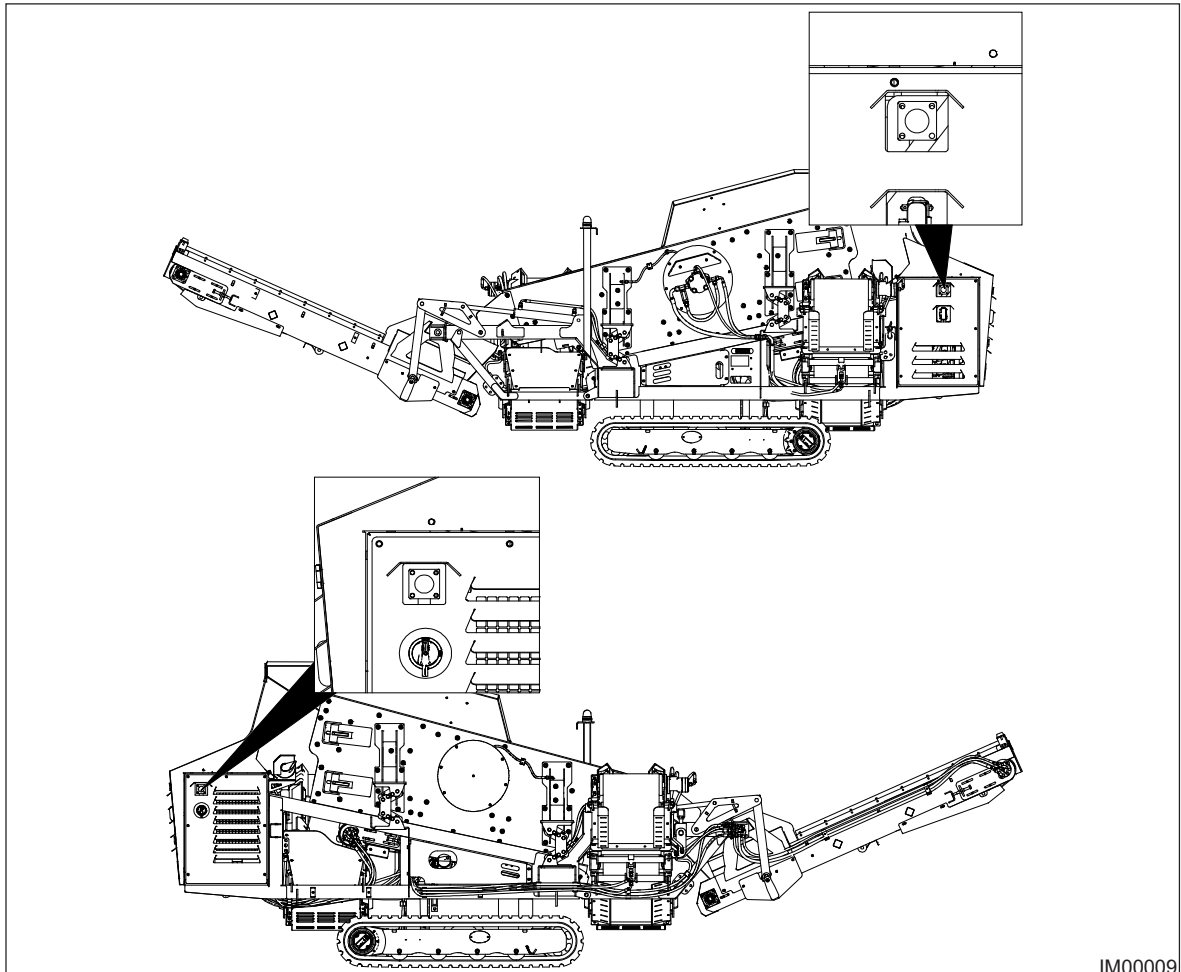

Fig: 9.13 - Emergency Stop Locations

IM00009

3. Switch off the ignition key and remove it.
4. Implement the lock and tag out procedure ("Implement The Lock & Tag Out" on page 2-25).
5. Do not attempt to rectify the issue unless the machine is fully isolated.

(1) Restart After Emergency Stop**NOTICE**

Only authorised, competent, and fully trained personnel are permitted to re-start the machine after an emergency shut down.

PROCEDURE

1. Observe all safety warnings.
2. Ensure the issue has been rectified.
3. Ensure that all guards and safety devices are correctly fitted and fully functional.
4. Ensure safety decals are still in place. Replace if necessary.
5. Ensure that all tools etc. have been cleared from around the machine including the walkways.
6. Release the emergency stop buttons.
7. Remove the lock and tag out ("Remove The Lock & Tag Out" on page 2-26).
8. Ensure that all personnel are clear of the machine.
9. Follow the correct engine start up procedure.
10. Do not leave the machine until certain the issue will not reoccur.
11. If the issue persists perform the emergency shut down procedure again and further investigate.

Table of Content

10	Machine Transport	10-2
10.1	Prior To Transport	10-3
(1)	Transport Sequence	10-3
10.2	Placing The Machine Into Transport Position	10-4
(1)	Task 1 -Activate Hydraulic System	10-4
(2)	Task 2 - Fold Oversize Conveyor.....	10-5
(3)	Task 3 - Fold Mid-Size Conveyor	10-7
(4)	Task 4 - Fold Fines Size Conveyor	10-9
(5)	Task 5 - Load Machine The On Transporter	10-11
(6)	Machine Tie Down Points	10-12

10 Machine Transport

DANGER

Crush Hazard.

Death or serious injury will result from contact with the crawler tracks when moving.

Keep clear of crawler tracks when the machine is maneuvering.

Electrocution Hazard.

Death or injury will result from contacting electric power lines.

Be aware of overhead power lines and cables routed along the ground when folding or moving the machine.

Always maintain the required clearance.

Always contact the electric power line owner if cables or power lines require to be disconnected. The electric supply shall be disconnected or the power lines moved or insulated prior to performing machine operations.

WARNING

Injection Hazard.

Escaping fluid under pressure can penetrate skin and result in death or serious injury. Relieve pressure before disconnecting hydraulic lines.

Keep away from leaks and pin holes. Use a piece of cardboard or paper to search for leaks. Do not use hand. Fluid injected into the skin must be surgically removed within a few hours by a doctor familiar with this type of injury, or gangrene will result.

Crush Hazard.

Stay clear of moving conveyors to prevent serious injury or death.

Ensure all personnel are clear of the machine when operating components.

Nip Point Hazard.

Nip points exist at conveyor pivot points.

Contact with pivot points can result in serious injury or death.

Fall Hazard.

It is a requirement for the use of an EN/ANSI safety harness when working above specific heights. Check with your local law and regulations authority for the specific height requirements.

Wear Personal Protective Equipment.

Personal Protective Equipment (PPE) must be worn at all times.

CAUTION

Caution shall be taken when placing this machine into the transport position. A thorough risk assessment shall be performed and all safety hazards addressed.

Only experienced and trained operators, familiar with this type of equipment are permitted to operate this machine.

Check local transport regulations before attempting to transport this machine.

The operator shall read and understand the full content of this handbook prior to starting the engine or performing any operating procedures.

10.1 Prior To Transport

PROCEDURE

1. Observe all safety warnings.
2. Ensure all material has discharged and the machine is running empty prior to shut down.
3. Shut down the machine.
4. Implement the lock and tag out procedure.
5. Refuel the machine if necessary.
6. Power wash the machine to remove all dust and debris. Do not power wash electrical components or in the engine compartment
7. Inspect the machine for any loose fittings, leaks or damage and fix where necessary.
8. Ensure no objects or tools etc. are on the machine.
9. Ensure there is adequate space and no obstructions around the machine.
10. Ensure no personnel are on or around the machine prior to placing into the transport position.

(1) Transport Sequence

NOTICE

To place the machine in the transport position correctly and prevent any damage to the equipment, the following tasks shall be performed in the given sequence.

PROCEDURE

1. "Task 1 -Activate Hydraulic System" on page 10-4
2. "Task 2 - Fold Oversize Conveyor" on page 10-5.
3. "Task 3 - Fold Mid-Size Conveyor" on page 10-7.
4. "Task 4 - Fold Fines Size Conveyor" on page 10-9.
5. "Task 5 - Load Machine The On Transporter" on page 10-11.

10.2 Placing The Machine Into Transport Position

SAFETY INSTRUCTION

Placing the machine into the transport position requires two people to be present at all times. Do not place this machine into the transport position alone.

(1) Task 1 -Activate Hydraulic System

NOTICE

The machines hydraulic system requires to be activated to enable the operator to use the hydraulic control levers located on the machine.

PROCEDURE

1. Observe all safety warnings.
2. Follow the procedure to start the engine.
3. On the Home Screen (Fig: 10.1), press the Activate Hydraulic System button (Item 4).
 - ◇ *The hydraulic system will become live and the control levers can now be operated.*



Fig: 10.1 - Home Screen

(2) Task 2 - Fold Oversize Conveyor

PROCEDURE

1. Observe all safety warnings.
2. Activate the hydraulic system ("Task 1 -Activate Hydraulic System" on page 10-4).
3. Proceed to the control levers located on the left-hand side of the machine (Fig: 10.2).

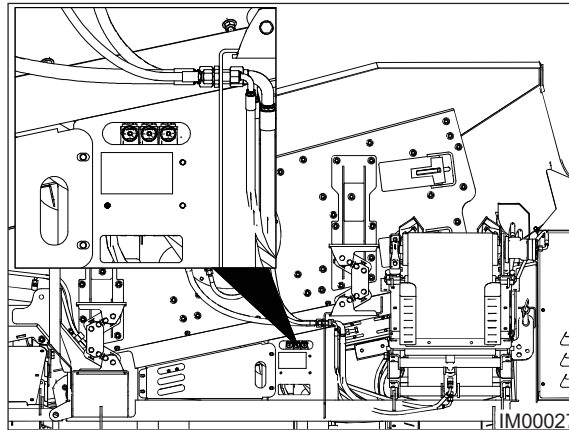

Fig: 10.2 - Control Levers

4. Slow and carefully push UP the control lever (Item 1, Fig: 10.3) to fold the oversize conveyor.
 - ◇ Observe the conveyor belt when folding. Adjust the belt position if necessary to prevent nips or tears.

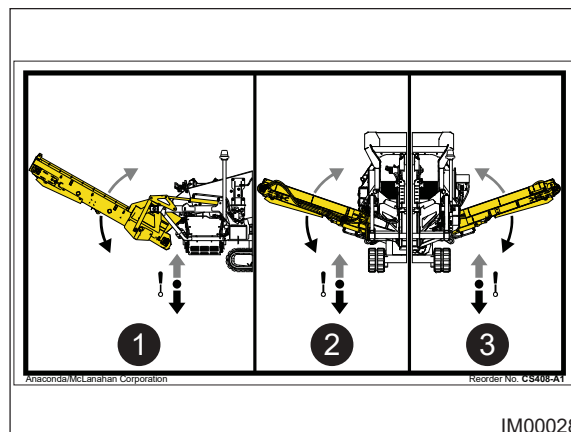

Fig: 10.3 - Control Levers

5. Once the conveyor has folded into the transport position (Fig: 10.4), release the control lever.

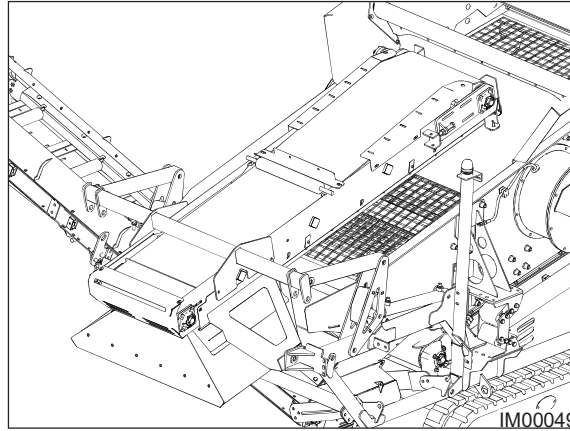

Fig: 10.4 - Oversize Conveyor

(3) Task 3 - Fold Mid-Size Conveyor

PROCEDURE

1. Observe all safety warnings.
2. Activate the hydraulic system ("Task 1 -Activate Hydraulic System" on page 10-4).
3. Proceed to the control levers located on the left-hand side of the machine (Fig: 10.5).

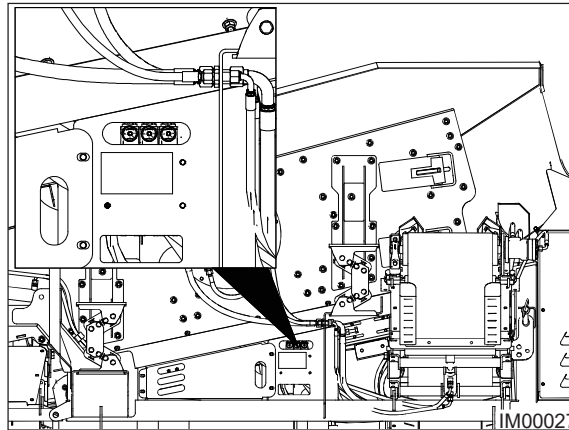

Fig: 10.5 - Control Levers

4. Slow and carefully push UP the control lever (Item 2, Fig: 10.6) to fold the mid-size conveyor.
 - ◇ Observe the conveyor belt when folding. Adjust the belt position if necessary to prevent nips or tears.

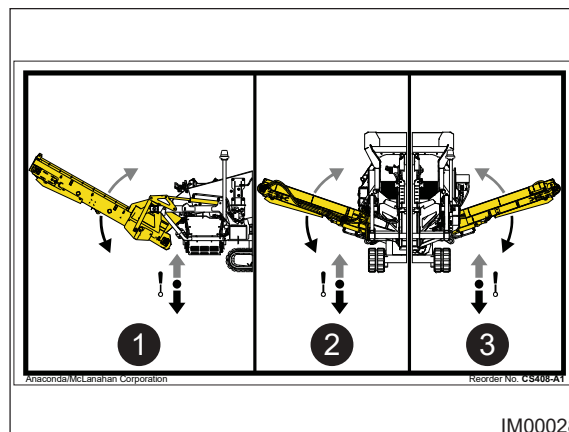

Fig: 10.6 - Control Levers

5. Once the conveyor has folded into the transport position (Fig: 10.7), release the control lever.

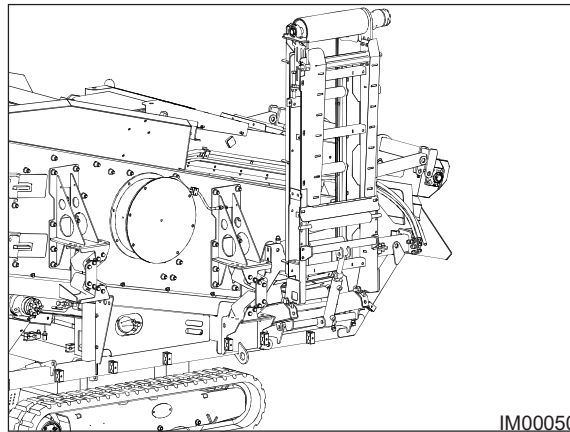

Fig: 10.7 - Mid-Size Conveyor

6. Insert the transport pin (Fig: 10.8) and secure.

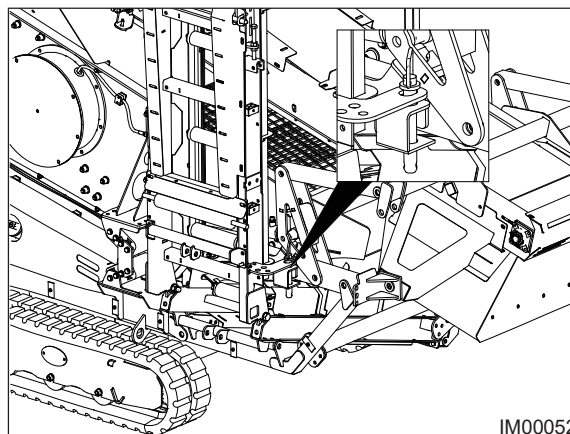

Fig: 10.8 - Transport Pin

(4) Task 4 - Fold Fines Size Conveyor

PROCEDURE

1. Observe all safety warnings.
2. Activate the hydraulic system ("Task 1 -Activate Hydraulic System" on page 10-4).
3. Proceed to the control levers located on the left-hand side of the machine (Fig: 10.9).

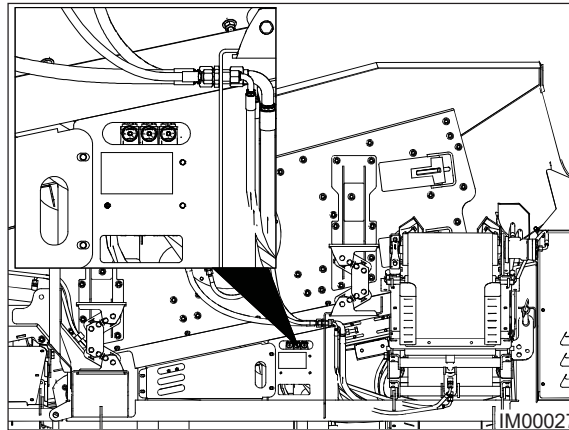

Fig: 10.9 - Control Levers

4. Slow and carefully push UP the control lever (Item 2, Fig: 10.10) to fold the mid-size conveyor.
 - ◇ Observe the conveyor belt when folding. Adjust the belt position if necessary to prevent nips or tears.

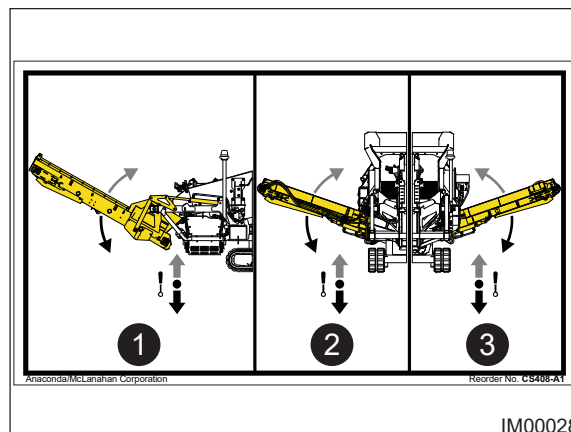

Fig: 10.10 - Control Levers

5. Once the conveyor has folded into the transport position (Fig: 10.11), release the control lever.

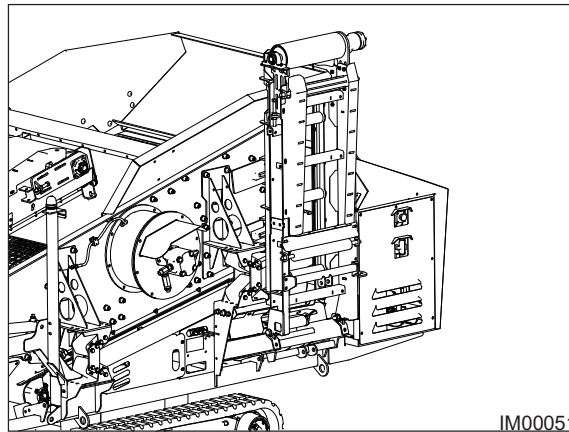

Fig: 10.11 - Fines Size Conveyor

6. Insert the transport pin (Fig: 10.12) and secure.

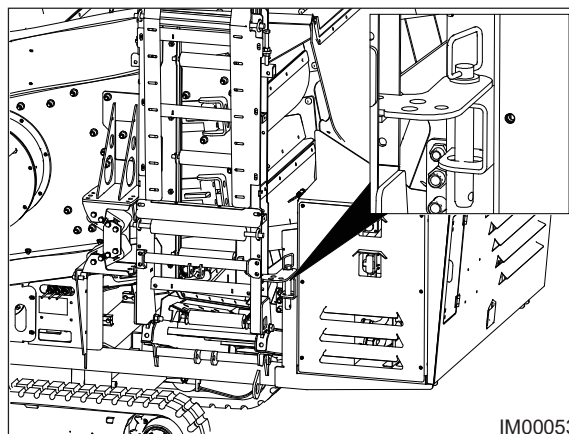

Fig: 10.12 - Transport Pin

(5) Task 5 - Load Machine The On Transporter

 **DANGER**

Crush Hazard.

Death or serious injury will result from contact with the crawler tracks when moving.
Keep clear of crawler tracks when the machine is maneuvering.

NOTICE

It is the responsibility of the haulage contractor to load and secure the machine to the transporter.

PROCEDURE

1. Observe all safety warnings.
2. Ensure the machine is in the correct transport position (Fig: 10.13).

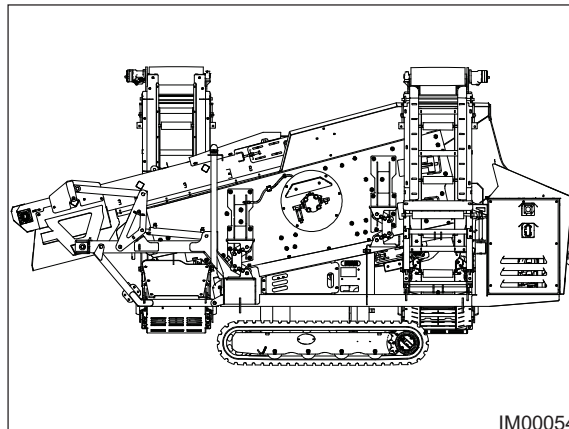

Fig: 10.13 - Transport Position

3. Ensure the transporter is capable of carrying the machines weight.
4. Place suitable ramps at the loading end of the transporter.
5. Ensure that any loose items are secured.
6. Follow tracking instructions and maneuver the machine onto the transporter.
7. Stop the engine and implement the lock and tag out procedure.
8. Remove ramps from the loading end of the transporter.
9. Secure the machine to the transporter using the machine tie down points ().

(6) Machine Tie Down Points

NOTICE

The tie down points are not to be used to lift or tow the machine.

The machine is secured at four tie down points. Two on the left and right-hand side of the machine (Fig: 10.14). Do not secure the machine to the transporter using the crawler tracks. Damage to the crawler tracks can occur.

It is the responsibility of the haulage contractor to secure this machine and any loose items to the transporter.

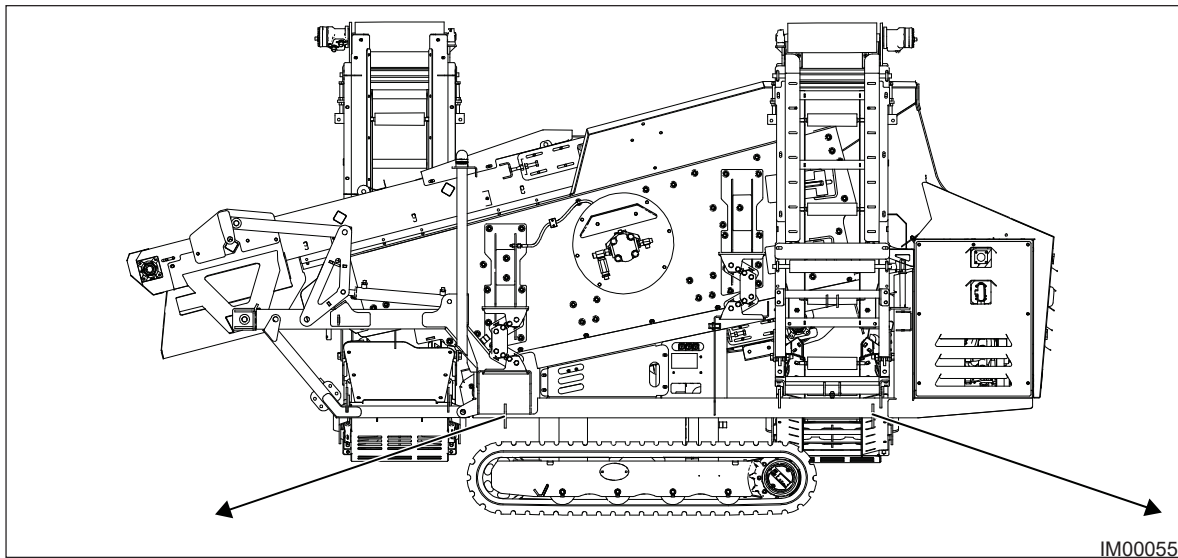

Fig: 10.14 - Tie Down Points

Table of Content

11	Maintenance	11-4
11.1	Safety Before and During Maintenance	11-4
11.2	Maintenance Schedules	11-5
	(1) Initial Checks (Running In).....	11-5
	(2) Prior Machine Start	11-5
	(3) Daily & Weekly Maintenance	11-6
	(4) Routine Maintenance.....	11-8
	(a) First 100 Hour Service Schedule.....	11-8
	(b) First 250 Hour Service Schedule.....	11-8
	(c) 250 Hour Service Schedule.....	11-8
	(d) 500 Hour Service Schedule.....	11-8
	(e) 1000 Hour Service Schedule.....	11-9
	(f) 2000 Hour Service Schedule.....	11-9
	(5) Engine Maintenance	11-10
	(a) When Required	11-10
	(b) Daily/10 Hour Service Schedule.....	11-10
	(c) Every 50 Service Hours or Weekly.....	11-10
	(d) Every 250 Service Hours.....	11-10
	(e) Every 250 Service Hours or 6 Months.....	11-10
	(f) Every 250 Service Hours or 1 Year	11-10
	(g) Initial 500 Hours	11-11
	(h) Every 500 Service Hours.....	11-11
	(i) Every 500 Service Hours or 1 Year	11-11
	(j) Every 1000 Service Hours.....	11-11
	(k) Every 1000 Hours Service Schedule.....	11-11
	(l) Every 2000 Service Hours.....	11-11
	(m) Every Year	11-11
	(n) Every 3000 Service Hours.....	11-12
	(o) Every 3000 Service Hours or 2 Years	11-12
	(p) Every 4000 Service Hours.....	11-12
	(q) Every 6000 Service Hours or 3 Years	11-12
	(r) Every 12 000 Service Hours or 6 Years	11-12
	(s) Overhaul.....	11-12
	(t) Commissioning.....	11-12
	(6) Lubrication Schedule	11-13
11.3	Lubricants & Fluids.....	11-14
	(1) Recommended Lubricants & Fluids.....	11-14
	(a) Engine Oil.....	11-14
	(b) Engine Coolant.....	11-14
	(c) Diesel Fuel	11-14
	(d) Crawler Track Gearboxes.....	11-14
	(e) Crawler Track Tensioning Grease	11-14
	(f) Conveyor Bearing Grease.....	11-14
	(g) Hydraulic Oil.....	11-15

	(h) Vibrating Screen Bearing Grease.....	11-15
	(2) Lubricant & Fluid Quantities.....	11-15
11.4	Crawler Track Maintenance.....	11-16
	(1) Correct Maintenance Procedure.....	11-16
	(2) Checking Track Tension.....	11-17
	(3) Adjustment Of Track Tension.....	11-18
	(a) Tightening the Track.....	11-18
	(b) Slackening the Track.....	11-19
	(4) Changing Track Belt.....	11-20
	(a) Removing the Track Belt.....	11-20
	(b) Refitting the Belt.....	11-22
	(5) Track Gearbox Maintenance.....	11-23
	(a) Oil Fitting & Draining.....	11-23
11.5	Engine Maintenance.....	11-24
	(1) Engine Oil Level - Check.....	11-24
	(2) Engine Oil And Filter - Change.....	11-26
	(a) Drain The Engine Oil.....	11-26
	(b) Replace The Oil Filter.....	11-27
	(c) Fill the Engine Crankcase.....	11-28
	(3) Servicing the Air Cleaner Element.....	11-29
	(a) Engine Air Cleaner Service Indicator - Inspect.....	11-30
	(b) Test The Service Indicator.....	11-30
	(4) Fuel System Maintenance.....	11-31
	(a) Fuel System Primary Filter/ Water Separator - Drain.....	11-31
	(b) Fuel System Primary Filter (Water Separator) Element - Replace.....	11-33
	(c) Fuel System Secondary Filter - Replace.....	11-34
	(d) Fuel System - Prime.....	11-35
	(e) Refuelling.....	11-37
	(5) Cooling System Coolant (DEAC) - Change.....	11-38
	(a) Cooling System Coolant Level - Check.....	11-38
	(b) Drain.....	11-39
	(c) Flush.....	11-39
	(d) Cooling Systems With Heavy Deposits Or Plugging.....	11-40
	(e) Fill.....	11-40
11.6	Conveyor Maintenance.....	11-42
	(1) All Conveyor Belts.....	11-42
	(a) Conveyor Daily Checks.....	11-42
	(b) Inspect & Clean.....	11-43
	(2) Oversize Conveyor.....	11-44
	(a) Belt Tensioning.....	11-44
	(b) Belt Alignment.....	11-45
	(3) Collection Conveyor.....	11-46
	(a) Belt Tensioning.....	11-46
	(b) Belt Alignment.....	11-47
	(4) Mid & Fines Size Conveyor.....	11-48
	(a) Belt Tensioning.....	11-48

- (b) Belt Alignment 11-49
- 11.7 Vibrating Screen Box Maintenance 11-50**
 - (1) Changing Screen Meshes 11-50
- 11.8 Hydraulic Oil Tank Maintenance 11-53**
 - (1) Hydraulic Tank Components 11-53
 - (2) Hydraulic Diagram 11-54
 - (3) Hydraulic Oil Level 11-55
 - (4) Hydraulic Oil & Suction Strainers Replacement 11-56
 - (5) Return Line Filter Replacement 11-58
- 11.9 Electrical Maintenance 11-59**
 - (1) Battery Checks 11-59
 - (2) Battery Removal 11-59
 - (3) Battery Installation 11-60
- 11.10 Hydraulic Cylinders - Care Of Chrome Recommendation 11-61**
- 11.11 Recommended Bolt Torque Settings 11-62**
 - (1) Maximum Bolt Loads And Torque Values (UNC Threads) 11-62
 - (2) Maximum Bolt Loads And Torque Values (UNF Threads) 11-62
 - (3) Maximum Bolt Loads And Torque Values (Metric Coarse Threads) 11-63
 - (4) A Guide To Torque Values 11-64

11 Maintenance

NOTICE

When maintenance or service is being performed a minimum of two people shall be present at all times. Never work alone.



CAUTION

Caution shall be taken when performing maintenance or service work on this machine. A thorough self risk assessment shall be carried out prior to working on the equipment and all safety hazards addressed.

Only experienced and trained operators, familiar with this type of equipment are permitted to work this machine.

The operator shall read and understand the full content of this handbook prior to performing any maintenance or service procedures.

11.1 Safety Before and During Maintenance

This section of the handbook contains maintenance instructions as well as maintenance schedules for normal operating conditions.

Before performing maintenance or repairs:

- Stop the engine.
- Operate controls to relieve all pressure.
- Allow the machine to cool.
- Implement lock and tag out procedure.

Never attempt repairs or adjustments to the machine while it is running (Exempt to this rule: Belt adjustments are only permitted during working process - see Belt Adjustments).

Only remove guards or covers that provide access. Wipe away excess grease and oil. Never leave guards off or access doors open when unattended.

Secure all hydraulically operated attachments with pins provided.

When working beneath raised equipment, always use blocks, jack-stands or other rigid and stable supports. Never work under unsupported equipment.

Care and attention shall be taken when working on or operating the machine, in case safety signs are missing or worn, ensure the operator knows how to operate machine before switching it on.

Replace any worn or missing safety signs on the machine.

All hydraulic cylinders shall be inspected weekly and 'care for chrome' program shall be adhered to.

If the machine is operated in extreme climatic conditions (below -15°C or above 33°C), or if in an extreme dusty environment for a long periods of time, the maintenance schedules will change. Contact your local technical department for advice.

When a bolt or nyloc nut becomes loose, replace with new. Do not reuse worn nyloc nuts or damaged bolts. Nyloc nuts shall be discarded after first use.

Ensure all components on the machine are kept in good working order and are correctly installed. Repair any damage immediately.

11.2 Maintenance Schedules

(1) Initial Checks (Running In)

NOTICE

Checks on the machine are crucial during the first week of operation.

- Run the machine empty for a short period of time and check for abnormal noises, vibration or excessive heat from the shaft bearings (vibrating screen).
- Inspect the engine oil level. Top up if necessary.
- Inspect the hydraulic oil level in the tank. Top up if necessary.
- Inspect the tension of the conveyor belts. Adjust if necessary.
- Inspect the alignment of the conveyor belts. Adjust if necessary.
- Ensure the machine is level, re-position if necessary.
- Inspect all belt scrapers/cleaners. Adjust if necessary.
- Inspect all skirting rubbers. Adjust if necessary.

(2) Prior Machine Start

- Visually check and inspect all guards, covers and doors are in position and secure, with tooling check machine for loose hardware.
- Ensure all warning and safety signs are clean and visible.
- Ensure that the screen unit and the feed hopper are empty.
- Do check frequently the stability of the machine. The chassis SHOULD NOT bounce during operation.
- Check the wear parts to ensure speed is suitable for the application and feed rate not excessive.

(3) Daily & Weekly Maintenance

NOTICE

Daily checks shall be performed everyday prior to the initial start-up of the machine. These basic tasks will help prevent unnecessary repairs and downtime.

When all checks have been made, close and fasten all guards before operating the machine.

Component	Task	Interval	
		10 Hours (Daily)	50 Hours (Weekly)
GENERAL			
Dust/debris build-up on machine components	Inspect/Remove/Clean	X	
Safety signs	Inspect/Clean/Replace	X	
All safety guards are fitted and secure	Inspect/Install/Secure	X	
Safety system is in tact, electronics, emergency stops, sensors	Inspect/Test/Repair	X	
Fuel level	Inspect/Replenish	X	
Nuts, bolts, fasteners and pins	Inspect/Install/Secure		X
Cabinet door gas struts	Inspect/Replace		X
VIBRATING SCREEN BOX			
Abnormal noise	Inspect/Rectify	X	
Mesh condition	Inspect/Replace	X	
Mesh tension	Inspect/Replace/Tighten	X	
Mesh cushion rubbers (if replacing meshes)	Inspect/Replace	X	
Vibration & Stroke reading	Inspect/Adjust	X	
Screen shaft speed (870 rpm)	Inspect/Adjust	X	
Screen bearings	Grease	X	
Vibrating motor, hoses, and fittings	Inspect/Replace/Tighten		X
Discharge chute condition	Inspect/Replace/Tighten		X
Screen bearing temperature (working temperature 60°C (140°F) - 80°C (176°F))	Inspect		X
CONVEYOR BELTS			
Belt alignment	Inspect/Adjust	X	
Belt tension	Inspect/Tension	X	
Conveyor belt - holes and tears	Inspect/Repair/Replace	X	
All rollers move freely/free from material build-up	Inspect/Clean/Replace	X	
Rubber skirting and clamps (where applicable)	Inspect/Adjust/Replace		X
Belt scrapers	Inspect/Adjust/Replace		X
Idle/Drive drum bearings	Grease		X
ENGINE			
Refer to the engine manufactures handbook for full maintenance schedules and procedures. The following checks are for guidance only.			
Cooling system coolant level	Inspect/Replenish	X	
Driven equipment	Check	X	
Air cleaner service indicator	Inspect	X	
Engine air cleaner	Inspect/Clean	X	
Engine oil level	Inspect/Replenish	X	
Walk around inspection	Inspect	X	
Fuel system primary filter/water separator	Inspect/Drain		X

Component	Task	Interval	
		10 Hours (Daily)	50 Hours (Weekly)
HYDRAULICS			
Oil level	Inspect/Replenish	X	
Hoses	Inspect/Replace/Tighten	X	
Hydraulic cylinders	Inspect	X	
Hydraulic pumps	Inspect	X	
Hydraulic drive motors	Inspect	X	
Hydraulic manifold	Inspect	X	
TRACKS			
Lower roller - oil leakage	Inspect/Tighten/Repair	X	
Track drive - oil leakage	Inspect/Tighten/Repair	X	
Build-up of grease, oil or debris	Inspect/Remove/Clean	X	
Loose nuts and bolts	Inspect/Tighten/Replace		X
Oil quantity	Inspect/Replenish		X
Rubber track - structural damage or failure	Inspect/Repair		X
Track tension	Inspect/Tension		X
Oil leaks & damaged hydraulic hoses	Inspect/Tighten		X
Manoeuvre machine 10 meters forward and back to prevent track seizure	Task		X

(4) Routine Maintenance

NOTICE

Routine maintenance shall be implemented when the corresponding interval arises. Failure to comply with scheduled maintenance can invalidate any warranty that applies to this machine.

In cases where the hourly maintenance interval has not been reached, the maintenance task must be performed every year, regardless.

(a) First 100 Hour Service Schedule

Component	Action	Comments	Sign
HYDRAULICS			
Carry out daily (10) hour maintenance schedule	Perform Tasks		
Carry out weekly (50) hour maintenance	Perform Tasks		
Replace return line filters	Replace		

(b) First 250 Hour Service Schedule

Component	Action	Comments	Sign
TRACKS			
Carry out daily (10) hour maintenance schedule	Perform Tasks		
Carry out weekly (50) hour maintenance	Perform Tasks		
Change gearbox oil	Change		

(c) 250 Hour Service Schedule

Component	Action	Comments	Sign
FIRST YOU MUST			
Carry out daily (10) hour maintenance schedule	Perform Tasks		
Carry out weekly (50) hour maintenance	Perform Tasks		
POWER UNIT			
Air cleaner elements	Check / Replace		
Radiator	Clean		
VIBRATING SCREEN			
Speed and Throw	Check / Adjust		

(d) 500 Hour Service Schedule

Component	Action	Comments	Sign
FIRST YOU MUST			
Carry out daily (10) hour maintenance schedule	Perform Tasks		
Carry out weekly (50) hour maintenance	Perform Tasks		
Carry out weekly (250) hour maintenance	Perform Tasks		
HYDRAULICS			
Hydraulic oil return line filter	Replace		

(e) 1000 Hour Service Schedule

Component	Action	Comments	Sign
FIRST YOU MUST			
Carry out daily (10) hour maintenance schedule	Perform Tasks		
Carry out weekly (50) hour maintenance	Perform Tasks		
Carry out weekly (250) hour maintenance	Perform Tasks		
Carry out weekly (500) hour maintenance	Perform Tasks		
TRACKS			
Change gearbox oil	Change		
HYDRAULIC SYSTEM			
Suction line filters (3 off)	Change if required		
Hydraulic Oil analysis			

(f) 2000 Hour Service Schedule

Component	Action	Comments	Sign
FIRST YOU MUST			
Carry out daily (10) hour maintenance schedule	Perform Tasks		
Carry out weekly (50) hour maintenance	Perform Tasks		
Carry out weekly (250) hour maintenance	Perform Tasks		
Carry out weekly (500) hour maintenance	Perform Tasks		
Carry out weekly (1000) hour maintenance	Perform Tasks		
HYDRAULIC SYSTEM			
Hydraulic oil	Change		
Hydraulic oil tank gaskets	Change		

(5) Engine Maintenance

NOTICE

The following information is given for guidance only. Always refer to the engine manufacturers handbook for full maintenance schedules and procedures.

(a) When Required

Task	Action	Comments	Sign
Battery	Replace		
Battery or battery cable	Disconnect		
Diesel exhaust fluid tank	Flush		
Engine	Clean		
Engine air cleaner element	Inspect / Clean / Replace		
Fuel system	Prime		
Severe service application	Check		

(b) Daily/10 Hour Service Schedule

Task	Action	Comments	Sign
Cooling system coolant level	Check		
Driven equipment	Check		
Engine air cleaner service indicator	Inspect		
Engine air pre-cleaner	Check / Clean		
Engine oil level	Check		
Fuel system primary filter / water separator	Drain		
Walk around inspection	Inspect		

(c) Every 50 Service Hours or Weekly

Task	Action	Comments	Sign
Fuel tank water and sediment	Drain		

(d) Every 250 Service Hours

Task	Action	Comments	Sign
Cooling system coolant sample (Level 1)	Obtain		

(e) Every 250 Service Hours or 6 Months

Task	Action	Comments	Sign
Cooling system coolant sample (Level 1)	Obtain		

(f) Every 250 Service Hours or 1 Year

Task	Action	Comments	Sign
Cooling system supplemental coolant additive (SCA)	Test / Add		

(g) Initial 500 Hours

(New Systems, Refilled Systems, & Converted Systems)

Task	Action	Comments	Sign
Cooling system coolant sample (Level 2)	Obtain		

(h) Every 500 Service Hours

Task	Action	Comments	Sign
Fan clearance	Check		
Fuel system secondary filter	Replace		

(i) Every 500 Service Hours or 1 Year

Task	Action	Comments	Sign
Battery electrolyte level	Check		
Cooling system supplemental coolant additive (SCA)	Test / Add		
Engine air cleaner element	Clean / Replace		
Engine oil and filter	Change		
Engine protective devices	Check		
Hoses and clamps	Inspect / Replace		
Radiator	Clean		

(j) Every 1000 Service Hours

Task	Action	Comments	Sign
Alternator and Fan Belts	Replace		
Engine Valve Lash	Inspect / Adjust		
Turbocharger	Inspect		

(k) Every 1000 Hours Service Schedule

Task	Action	Comments	Sign
Belt tensioner	Check		
Belt	Inspect		
Water pump	Inspect		

(l) Every 2000 Service Hours

Task	Action	Comments	Sign
Aftercooler core	Inspect		
Alternator	Inspect		
Engine crankcase breather	Replace		
Engine mounts	Inspect		
Starter motor	Inspect		

(m) Every Year

Task	Action	Comments	Sign
Cooling System Coolant Sample (Level 2)	Obtain		

(n) Every 3000 Service Hours

Task	Action	Comments	Sign
Fuel injector	Test / Change		
Water pump	Inspect		

(o) Every 3000 Service Hours or 2 Years

Task	Action	Comments	Sign
Cooling system coolant (DEAC)	Change		
Cooling system water temperature regulator	Replace		

(p) Every 4000 Service Hours

Task	Action	Comments	Sign
Aftercooler core	Clean / Test		

(q) Every 6000 Service Hours or 3 Years

Task	Action	Comments	Sign
Cooling system coolant extender (ELC)	Add		

(r) Every 12 000 Service Hours or 6 Years

Task	Action	Comments	Sign
Coolant (ELC)	Change		

(s) Overhaul

Task	Action	Comments	Sign
Overhaul	Overhaul Consideration		

(t) Commissioning

Task	Action	Comments	Sign
Fan clearance	Check		

(6) Lubrication Schedule

NOTICE

Ensure that bearings are lubricated as outlined in the lubrication schedule. Over lubricating or lack of lubrication will result in bearing failures.

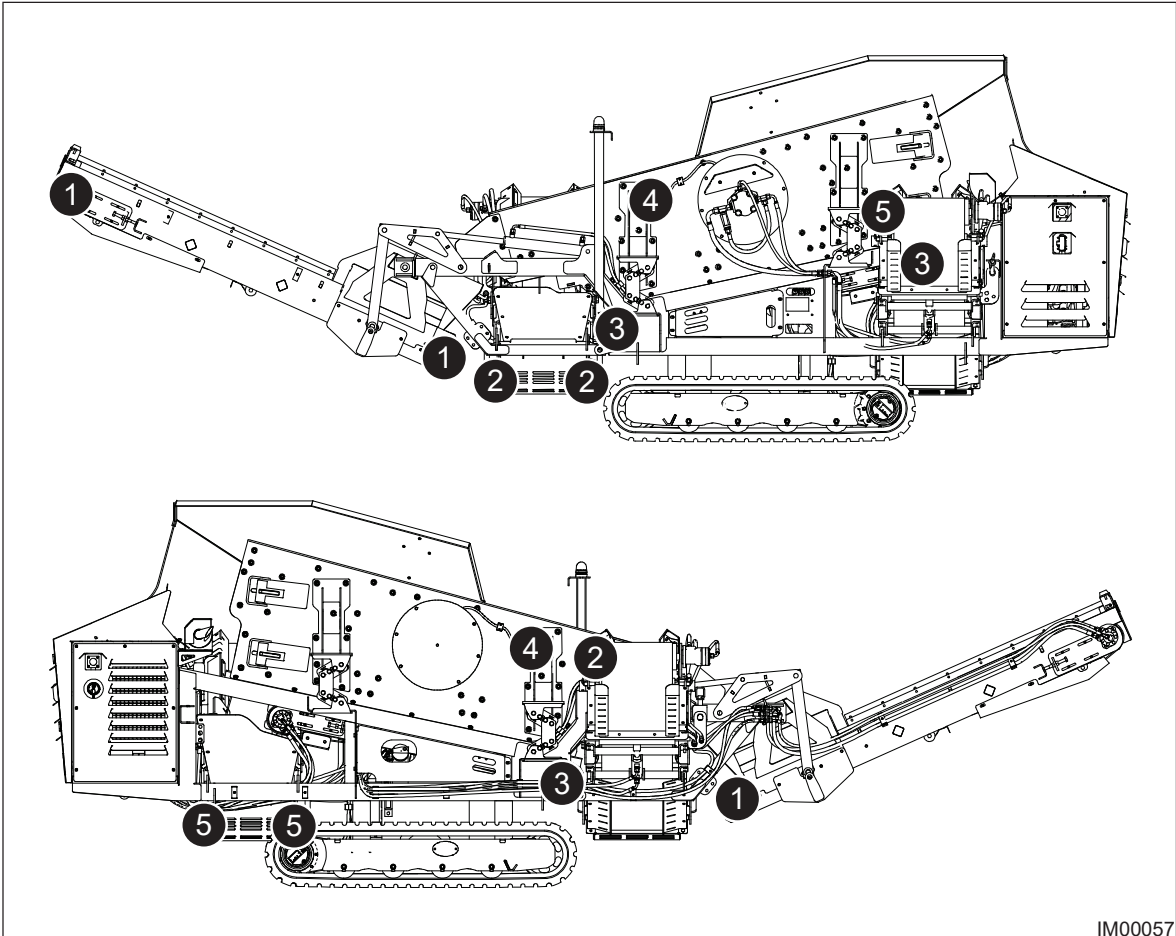

IM00057

Fig: 11.1 - Grease Points

Item	Description	Grease Quantity (Per Bearing)	Interval
1	Oversize Conveyor Drive Drum Bearing (1 off)	4 grams	50 Hours
	Oversize Conveyor Idle Drum Bearing (2 off)		
2	Mid-Size Conveyor Drive Drum Bearing (1 off)	4 grams	50 Hours
	Mid-Size Conveyor Drive Drum Bearing (2 off)		
3	Collection Conveyor Drive Drum Bearing (1 off)	4 grams	50 Hours
	Collection Conveyor Idle Drum Bearing (2 off)		
4	Vibrating Screen - Drive Side (1 off)	5 grams	10 Hours
	Vibrating Screen - Non-Drive Side (1 off)		
5	Fines-Size Conveyor Drive Drum Bearing (1 off)	4 grams	50 Hours
	Fines-Size Conveyor Drive Drum Bearing (2 off)		

11.3 Lubricants & Fluids

(1) Recommended Lubricants & Fluids

NOTICE

It is important that the correct grade and specification of lubricant or fluid is used on each component of the machine. Lubricants and fluids can have special additives and characteristics that are vital to the machines performance and functionality. If you require the detailed specifications of the recommended lubricants and fluids listed, please contact your local dealer or technical department. Never use lubricants or fluids that are not recommended. Damage to the machine can occur.

(a) Engine Oil

Lubricant Viscosities for Ambient Temperatures						
Compartment	Oil Type and Performance Requirements	Oil Viscosities	°C		°F	
			Min	Max	Min	Max
Engine Crankcase	Cat DEO-ULS Cold Weather	SAE 0W-40	-40	40	-40	104
	Cat DEO-ULS	SAE 10W-30	-18	40	0	104
	Cat DEO-ULS	SAE 15W-40	-9.5	50	15	122

Refer to engine manufacturers handbook for full information.

(b) Engine Coolant

Component	International Spec	Grade
Engine Coolant	EC-1 (Preferred)	Cat ELC (Preferred)
	ASTM D6210 (Acceptable)	Cat DEAC (Acceptable)

Refer to engine manufacturers handbook for full information.

(c) Diesel Fuel

Component	International Spec
Diesel Fuel	ASTM D975 EN 590

Refer to engine manufacturers handbook for full information.

(d) Crawler Track Gearboxes

Component	International Spec	Grade
Crawler Track Gearbox Oil	DIN 51517-3	CLP220

(e) Crawler Track Tensioning Grease

Component	International Spec	Grade
Crawler Track Grease		EP 2

(f) Conveyor Bearing Grease

Component	International Spec	Grade
Conveyor Bearings		EP 2

(g) Hydraulic Oil

Component	Temperature Range	Specification
Hydraulic Oil	Up to 30°C (86°F)	ISO VG 46
	Above 30°C (86°F)	ISO VG 68
For climates that are not within the ranges stated, contact your local dealer or technical support.		

(h) Vibrating Screen Bearing Grease

Component	International Spec	Grade
Vibrating Screen Bearings		EP 2-Lithium Complex Grease

(2) Lubricant & Fluid Quantities

Engine Oil		Coolant (Engine Only)	Hydraulic Oil	Track Gearboxes (per gearbox)	Diesel Tank
Minimum	Maximum				
3.4 L (3.6 qt)	4.4 L (4.6 qt)	1.9L (2.0 qt)	80 L (21.1 US GAL)	To Fill Level Plug (Refer to crawler track maintenance)	120 L (32 US GAL)

11.4 Crawler Track Maintenance



DANGER

Crush Hazard.

Death or serious injury will result from contact with the crawler tracks when moving.

Keep clear of crawler tracks when the machine is maneuvering.

(1) Correct Maintenance Procedure

NOTICE

In order to maintain the reliability of the track systems, regular maintenance is essential. It is imperative that the tracks are maintained as outlined within this maintenance section. Additional maintenance shall be adhered to from the track manufacturer's handbook.

ALWAYS:

- Perform maintenance on a level and solid surface.
- Ensure the track system is solidly supported if work is necessary under the track systems.
- Remove any build-up of grease, oil or debris.
- Repair all damage and replace worn or broken parts immediately.
- Check for oil leaks and damaged hydraulic hoses.
- Use only specified lubricants. Do not mix different brands or types.
- Use great care when maintaining the hydraulic system since oil may be very hot when the machine has just been working.
- Use only genuine, supplied / approved replacement parts. Use of unapproved parts will invalidate the warranty.
- Dispose of lubricants in the proper manner.
- Dispose of worn tracks in the proper manner.

(2) Checking Track Tension

NOTICE

Do not operate the tracks with the belt incorrectly tensioned. Too loose and there is a risk it could de-track. Too tight and damage could be caused to the system.

PROCEDURE

1. Observe all safety warnings.
2. Stop your machine on solid level ground and drive 2 m / 7 ft (minimum) in a forward direction.
3. Switch off the engine and implement the lock and tag out.
4. Carefully pull up centre of belt and measure distance between top of frame and the belt's running surface (Fig: 11.2).

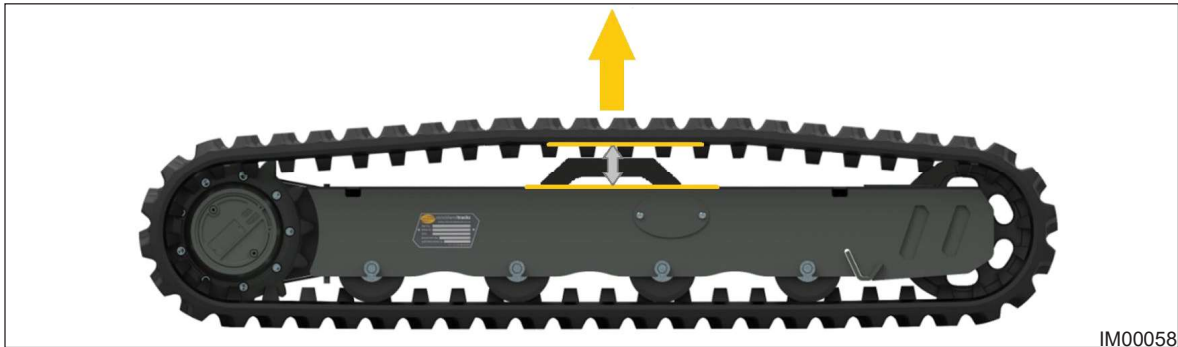

Fig: 11.2 - Measurement

IM00058

The sag of the belt shall be between the following values dependent on machine weight.

General Tension Guidelines	Guideline distance ±10mm	These values should only be used as general guidelines. Always use common sense when tensioning the belt and refer to any model specific information first.
<2.5T	60mm	
2.5T - 5.5T	70mm	
5.5T - 14T	80mm	

The above conditions shall be fulfilled on any new track system. This shall also be regularly checked and corrected where necessary by adding grease to the grease tensioner, as described in Section ("Adjustment Of Track Tension" on page 11-18).

(3) Adjustment Of Track Tension

SAFETY INSTRUCTION

Adjustment of track tension involves working with grease contained at high pressure and shall only be carried out by qualified fitters. Otherwise, contact your local service department.

Track systems use a grease cylinder to keep each track chain in tension. Screwed into the end of the grease cylinder is a grease fitting, enabling grease to be pumped into the grease chamber tightening the track. If this valve is loosened grease will escape causing the track to de-tension.



Fig: 11.3 - Grease Cylinder

Shown is a typical idler and tensioner assembly used on the rubber track system (Fig: 11.3). This is supplied as a whole unit. On some systems, the assembly is supplied as individual components. The grease inside the track tensioner (Lithium EP2) is pressurised so care shall be taken when loosening the grease fitting.

(a) Tightening the Track

PROCEDURE

1. Observe all safety warnings.
2. Switch off the engine and implement the lock and tag out.
3. Loosen one of the two screws and swing access cover away from access aperture on the side of the track frame (Fig: 11.4).

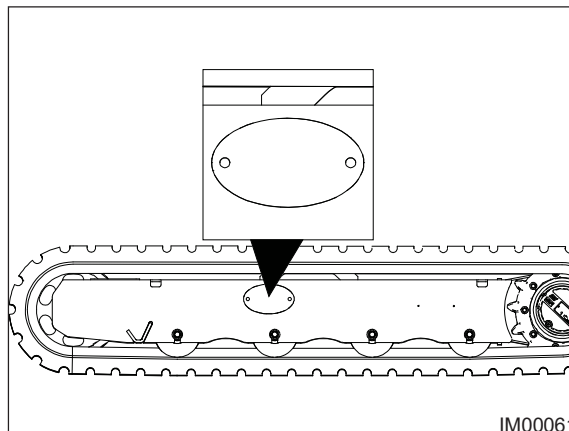

Fig: 11.4 - Access Cover

4. Ensure the grease fitting and grease gun adaptor are clean; ingress of dirt into the grease fitting can result in failure.
5. Connect a grease gun to the grease fitting and add grease until the track tension is within the specified values given in "Checking Track Tension" on page 11-17.
6. Remove the lock and tag out.
7. Start the engine.
8. Maneuver 50 metres forwards and 50 metres backwards and repeat the procedure if the track slackens.

(b) Slackening the Track

NOTICE

If the track fails to slacken after grease fitting has been loosened; DO NOT attempt to remove the tracks or disassemble the track tensioner, and DO NOT remove the grease fitting from the tensioner. It is possible that running the tracks a short distance in both directions with the grease fitting loosened may help to expel the grease.

PROCEDURE

1. Observe all safety warnings.
2. Switch off the engine and implement the lock and tag out.
3. Loosen one of the two screws and swing access cover away from access aperture on the side of the track frame (Fig: 11.4).
4. Loosen the grease fitting, by turning in an anti-clockwise direction, using gradual increments until the grease begins to be expelled. Care shall be taken not to loosen the grease fitting too quickly.
5. When the correct track tension has been obtained, tighten the grease fitting by turning in a clockwise direction and clean away all trace of extruded grease. Be sure not to over tighten the grease fitting.

(4) Changing Track Belt**(a) Removing the Track Belt****SAFETY INSTRUCTION**

The following procedure involves heavy components, use appropriate lifting equipment to prevent injury to operators and bystanders.

PROCEDURE

1. Observe all safety warnings.
2. To remove the track belt first ensure the machine is in a safe flat working area on solid ground.
3. Switch off the engine and implement the lock and tag out.
4. Lift up the machine and support it with the tracks safely off the ground.
5. Remove the idler tensioner cover plate and loosen the tensioner valve no more than 1 turn counter-clockwise.
6. If the grease does not start to drain out then slowly rotating the track can help (Fig: 11.5).

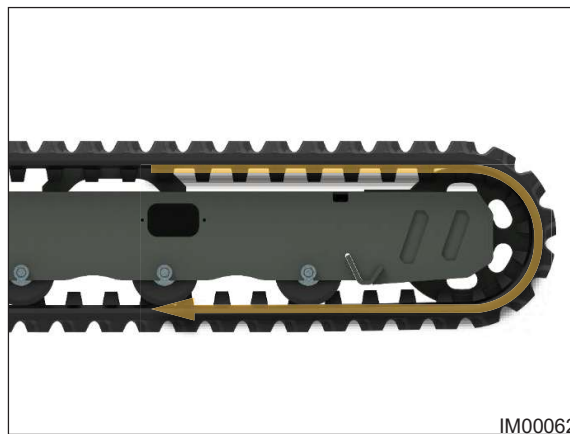

Fig: 11.5 - Rotating Track

7. Insert steel tubes as shown (Fig: 11.6) and slowly rotate the track in reverse. This draws the tubes between the idler and the belt and de-tensions the track.

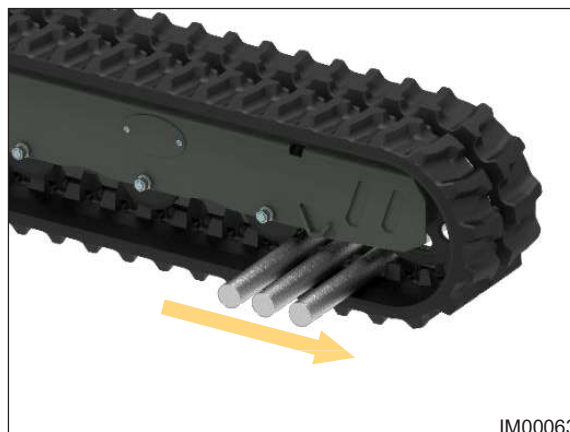

Fig: 11.6 - Steel Tubes

8. Slide the belt off at the idler end using the tubes to help if required, then remove the belt from the sprocket end (Fig: 11.7).



Fig: 11.7 - Belt Removal

(b) Refitting the Belt**PROCEDURE**

1. Observe all safety warnings.
2. Support the machine safely off the ground, fit the new belt over the sprocket end first.
3. With the idler fully retracted fit the belt over the idler (Fig: 11.8).

*Fig: 11.8 - Idler Retracted*

4. Ensure the sprocket is meshed properly and the belt is seated correctly on the rollers.
5. Tighten the valve and slowly apply grease. The Idler will gradually move out to its working position.
6. Set to the correct tension (Fig: 11.9) using the test methods mentioned in "Adjustment Of Track Tension" on page 11-18.

*Fig: 11.9 - Idler Tension*

7. Clean off any loose grease and refit tensioner cover plate.
8. Lower the machine back to the floor and check the machine by briefly tracking in each direction checking for belt slip/ de-tracking.
9. If not tensioned correctly, repeat "Adjustment Of Track Tension" on page 11-18.

(5) Track Gearbox Maintenance

NOTICE

Do not fill oil in the track drive without checking oil level inside it. All track systems are supplied with a measured quantity of oil in the track drive.

(a) Oil Fitting & Draining

Below are the 3-common oil filling/draining configurations, if your gearbox is not shown below please contact your local dealer for further details.

To fill, track the machine until the gearbox casing is level with a plug positioned as shown below. Fill from the upper hole until oil reaches the level indicated.

To drain, track the machine until a plug is at 6 o'clock position as shown below. Unscrew both plugs and allow all oil to discharge into a suitable container. Dispose of waste oil in a safe and approved way.

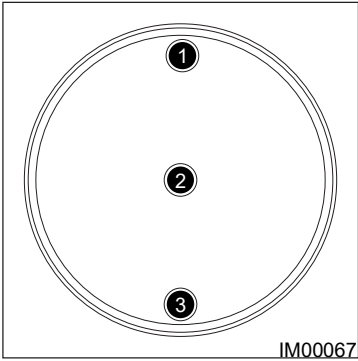
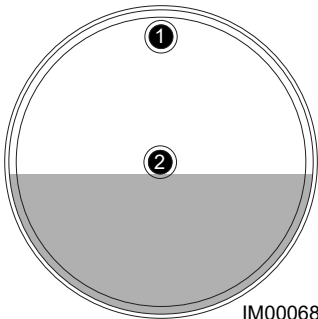
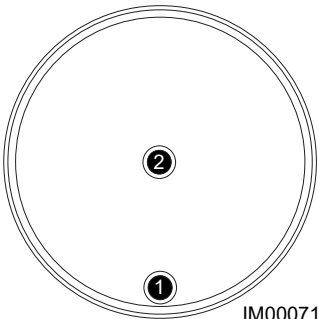
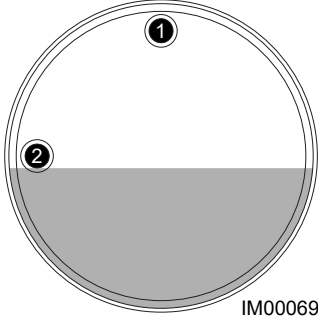
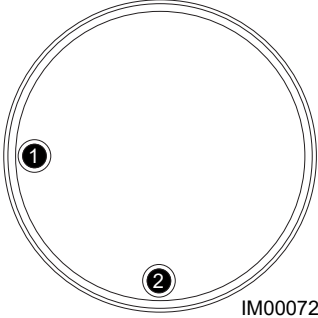
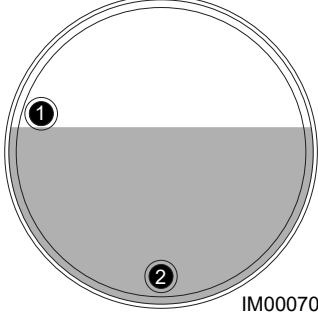
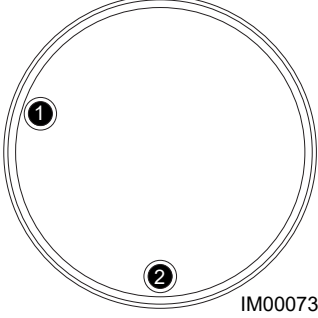
Oil Plugs Position	Oil Filling	Oil Draining
 <p>IM00067</p> <ol style="list-style-type: none"> 1. Oil Fill Plug 2. Oil Level Plug 3. Oil Drain Plug 	 <p>IM00068</p>	 <p>IM00071</p>
	 <p>IM00069</p>	 <p>IM00072</p>
	 <p>IM00070</p>	 <p>IM00073</p>

11.5 Engine Maintenance

NOTICE

Refer to the engine manufacturers handbook for full maintenance procedures. The maintenance procedures outlined in this handbook are provided for basic maintenance only. Further maintenance procedures are required and shall be performed by an experienced service engineer familiar with this type of engine.

(1) Engine Oil Level - Check



WARNING

Hot oil and hot components can cause personal injury. Do not allow hot oil or hot components to contact the skin.

NOTICE

Operating your engine when the oil level is above the "FULL" mark could cause your crankshaft to dip into the oil. The air bubbles created from the crankshaft dipping into the oil reduces the oil's lubricating characteristics and could result in the loss of power.

Perform this maintenance with the engine stopped.

PROCEDURE

1. Observe all safety warnings.
2. Switch off the engine and implement the lock and tag out.
3. Remove the dipstick (Fig: 11.10) and clean with a lint free cloth.

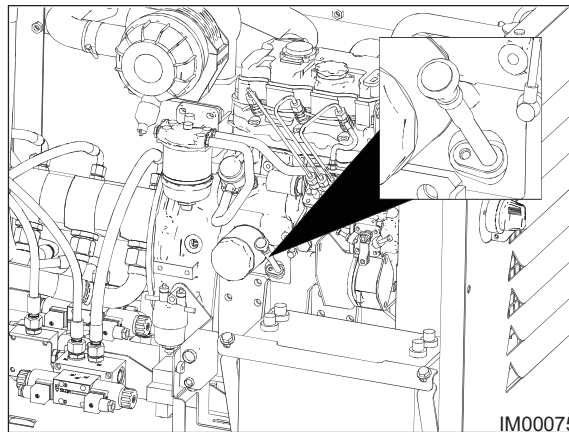
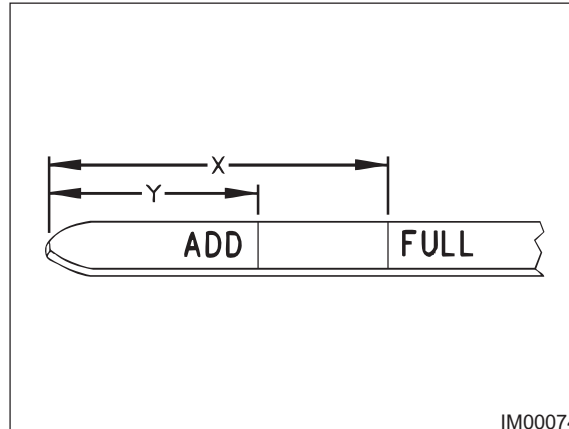

Fig: 11.10 - Dipstick

4. Maintain the oil level between "ADD" mark (Y) and "FULL" mark (X) on oil level gauge (Fig: 11.11). Do not fill the crankcase above "FULL" mark (X).



IM00074

Fig: 11.11 - Oil Level Gauge

5. Remove the oil filler cap (Fig: 11.12) and add oil, if necessary.

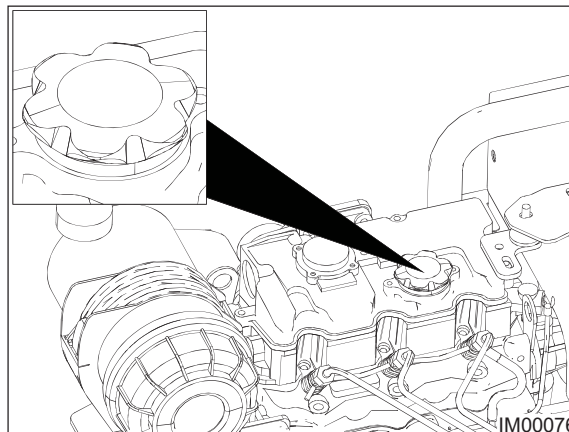

IM00076

Fig: 11.12 - Filler Cap

6. Clean the oil filler cap. Install the oil filler cap.

(2) Engine Oil And Filter - Change**WARNING**

Hot oil and hot components can cause personal injury. Do not allow hot oil or hot components to contact the skin.

NOTICE

Care must be taken to ensure that fluids are contained during performance of inspection, maintenance, testing, adjusting and repair of the product.

Be prepared to collect the fluid with suitable containers before opening any compartment or disassembling any component containing fluids.

Dispose of all fluids according to local regulations and mandates.

Keep all parts clean from contaminants.

Contaminants may cause rapid wear and shortened component life.

Do not drain the oil when the engine is cold. As the oil cools, suspended waste particles settle on the bottom of the oil pan. The waste particles are not removed with the draining cold oil. Drain the crankcase with the engine stopped. Drain the crankcase with the oil warm. This draining method allows the waste particles that are suspended in the oil to be drained correctly.

Failure to follow this recommended procedure will cause the waste particles to be recirculated through the engine lubrication system with the new oil.

The standard engine oil and filter change period is 500 hours. There are several other factors that can alter the standard engine oil and filter change of 500 hours.

- If the engine is using engine oil analysis to determine oil and filter change period.
- The engine is working in a severe service environment/Load Factor
- Infrequent operation of the engine

Refer to the engine manufacturers handbook, "Severe Service Application" for more information on reducing the engine oil and filter change period. For severe service applications the recommended oil and filter change period is 250 hours.

If the engine is operated in severe service conditions, it is recommended the use of engine oil sampling. Refer to engine manufacturer handbook "Oil Analysis" for more information.

If the engine is operated infrequently less than 500 hours in a 12-month period, then the engine oil and filter change should be conducted yearly.

(a) Drain The Engine Oil**PROCEDURE**

1. Observe all safety warnings.
2. Allow the engine to run at the normal operating temperature.
3. Switch off the engine and implement the lock and tag out.
4. Place a suitable container, capable of holding all the oil beneath the engine.
5. Remove the drain plug from the engine sump (Fig: 11.13) and allow all of the oil to drain into the container.

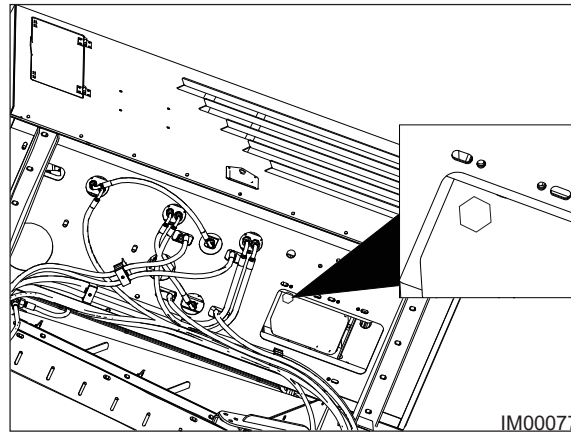

Fig: 11.13 - Engine Sump

6. After the oil has drained, the oil drain plug shall be cleaned and reinstalled.

(b) Replace The Oil Filter

NOTICE

The engine oil filter is built to the engine manufacturers specifications. Use of an oil filter not recommended by the engine manufacturer can result in severe engine damage to the engine bearings, crankshaft, etc., as a result of the larger waste particles from unfiltered oil entering the engine lubricating system. Only use oil filters recommended by the engine manufacturer.

Do not fill the oil filters with oil before installing them. This oil would not be filtered and could be contaminated. Contaminated oil can cause accelerated wear to engine components or engine damage.

PROCEDURE

1. Observe all safety warnings.
2. Follow the procedure to drain the oil ("Drain The Engine Oil" on page 11-26).
3. Remove the oil filter (Fig: 11.14) with a 1U-8760 chain wrench.

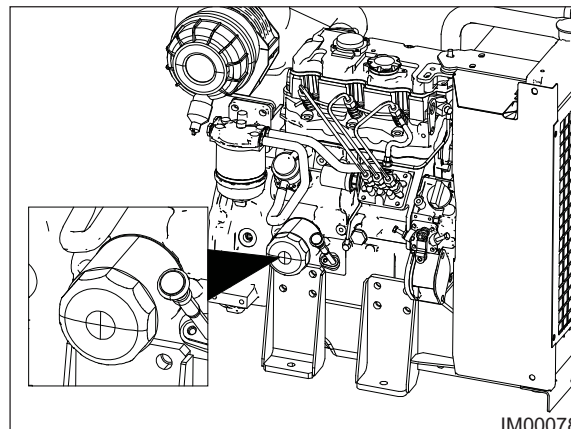

Fig: 11.14 - Oil Filter

4. Apply clean engine oil to the new oil filter seal.
5. Install the new oil filter.
6. Tighten the oil filter until the oil filter seal contacts the cylinder block. Tighten the oil filter by hand according to the instructions that are shown on the oil filter. Do not overtighten the oil filter.

(c) Fill the Engine Crankcase**NOTICE**

To prevent crankshaft bearing damage, crank the engine with the fuel OFF. This will fill the oil filters before starting the engine. Do not crank the engine for more than 30 seconds.

PROCEDURE

1. Observe all safety warnings.
2. Remove the oil filler cap (Fig: 11.15).

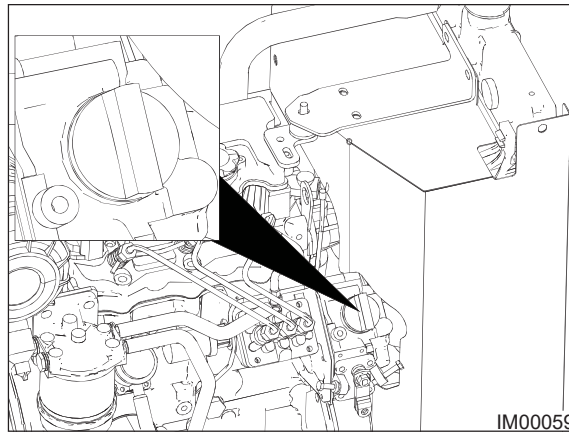

Fig: 11.15 - Filler Cap

3. Fill the crankcase with the correct amount of oil ("Lubricant & Fluid Quantities" on page 11-15)..
4. Start the engine and run the engine at low idle for 2 minutes. Perform this procedure to ensure that the lubrication system has oil and that the oil filters are filled.
5. Inspect the oil filter for oil leaks.
6. Stop the engine and allow the oil to drain back to the sump for a minimum of 10 minutes.
7. Check the engine oil level and top up if necessary ("Engine Oil Level - Check" on page 11-24).

(3) Servicing the Air Cleaner Element

NOTICE

If the air cleaner element becomes plugged, the air can split the material of the air cleaner element. Unfiltered air will drastically accelerate internal engine wear. Refer to the OEM information for the correct air cleaner elements for your application.

- Check the air cleaner service indicator daily.
- Check the dust bowl daily for accumulation of dirt and debris. Remove any dirt and debris, as needed.
- Operating in dirty conditions may require more frequent service of the air cleaner element.

Replace the dirty air cleaner elements with new air cleaner elements. Before installation, the air cleaner elements should be thoroughly checked for tears and/or holes in the filter material. Inspect the gasket or the seal of the air cleaner element for damage.

Maintain a supply of suitable air cleaner elements for replacement purposes.

PROCEDURE

1. Observe all safety warnings.
2. Switch off the engine and implement the lock and tag out.
3. On the air cleaner (Fig: 11.16), depress the button (Item 1) and rotate cover (Item 2) counter-clockwise. Remove cover (Item 2) from main body of air cleaner (Item 3). Ensure that the inner of cover (Item 2) is clean and free from dirt.

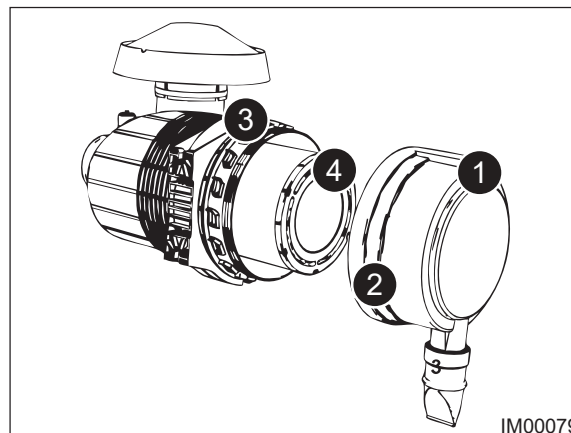

Fig: 11.16 - Air Cleaner

4. Remove old air filter element (Item 4, Fig: 11.16) and discard.
5. Ensure that the inner of the main body of the air cleaner (Item 3, Fig: 11.16) is clean and free from dirt.
6. On the air cleaner (Fig: 11.16), install the new air filter element (Item 4) into the main body of the air cleaner (Item 3). Align the cover (Item 2) to main body of air cleaner (Item 3) and turn cover clockwise (Item 2) until the cover locks into position.

(a) Engine Air Cleaner Service Indicator - Inspect**NOTICE**

The differential gauge for inlet air pressure displays the difference in the pressure that is measured before and after the air cleaner element. As the air cleaner element becomes dirty, the pressure differential rises.

PROCEDURE

1. Observe all safety warnings.
2. Observe the service indicator (Fig: 11.17). The air cleaner element shall be cleaned or the air cleaner element shall be replaced when one of the following conditions occur:

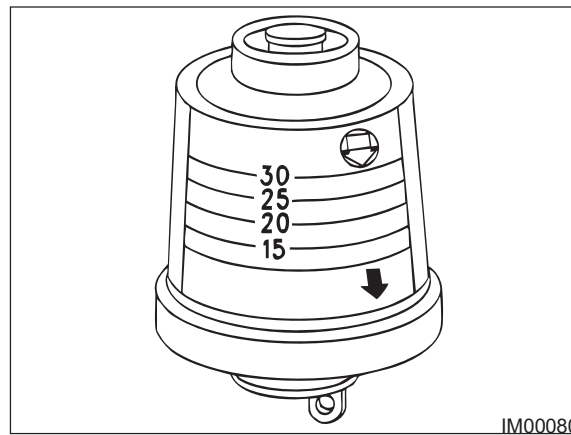

Fig: 11.17 - Service Indicator

- The yellow diaphragm enters the red zone.
- The red piston locks in the visible position.

(b) Test The Service Indicator

Service indicators are important instruments.

- Check for ease of resetting. The service indicator should reset in less than three pushes.
- Check the movement of the service indicator core when the engine is run at full load speed. The core should latch approximately at the greatest vacuum that is attained.

If the service indicator does not reset easily, or if the core does not latch at the greatest vacuum, the service indicator shall be replaced. If the new service indicator will not reset, the hole for the service indicator may be plugged.

If necessary, replace the service indicator more frequently in environments that are severely dusty. Replace the service indicator annually regardless of the operating conditions. Replace the service indicator when the engine is overhauled, and whenever major engine components are replaced.

(4) Fuel System Maintenance **DANGER****Explosion/Burn Hazard.**

Fuel and fumes can explode and burn, resulting in death or serious injury.

No smoking.

Keep all open flames and sparks away.

Stop engine before adding fuel.

Never remove filler cap or refuel, with the engine running.

 **WARNING**

Fuel leaked or spilled onto hot surfaces or electrical components can cause a fire. To help prevent possible injury, turn the start switch off when changing fuel filters or water separator elements. Clean up fuel spills immediately.

NOTICE

Ensure that the engine is stopped before any servicing or repair is performed.

Care must be taken to ensure that fluids are contained during performance of inspection, maintenance, testing, adjusting and repair of the product. Be prepared to collect the fluid with suitable containers before opening any compartment or disassembling any component containing fluids.

Do not allow dirt to enter the fuel system. Thoroughly clean the area around a fuel system component that will be disconnected. Fit a suitable cover over disconnected fuel system component.

Dispose of all fluids according to local regulations and mandates.

(a) Fuel System Primary Filter/ Water Separator - Drain**NOTICE**

The water separator is not a filter. The water separator separates water from the fuel. The engine should never be allowed to run with the water separator more than half full. Engine damage may result.

The water separator is under suction during normal engine operation. Ensure that the drain valve is tightened securely to help prevent air from entering the fuel system.

PROCEDURE

1. Observe all safety warnings.
2. Switch off the engine and implement the lock and tag out.
3. Open the drain valve (Item 1, Fig: 11.18) and catch the draining fluid in a suitable container. Dispose of the drained fluid correctly.

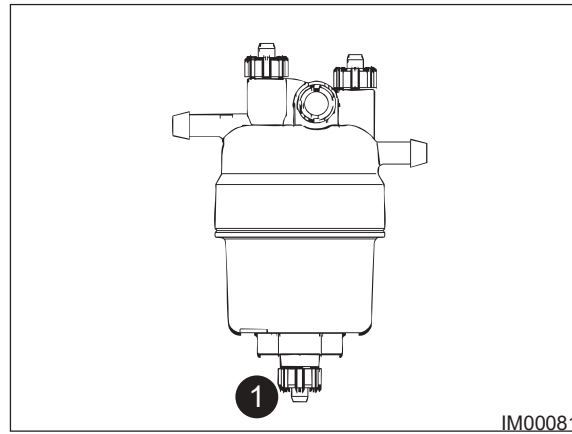

Fig: 11.18 - Water Separator

IM00081

4. Close drain valve (Item 1, Fig: 11.18).

(b) Fuel System Primary Filter (Water Separator) Element - Replace

NOTICE

The secondary filter element shall be replaced at the same time as the primary filter element ("Fuel System Secondary Filter - Replace" on page 11-34).

PROCEDURE

1. Observe all safety warnings.
2. Switch off the engine and implement the lock and tag out.
3. Place a suitable container under the water separator in order to catch any fuel that might spill.
4. Clean the outside body of the filter assembly (Fig: 11.19).

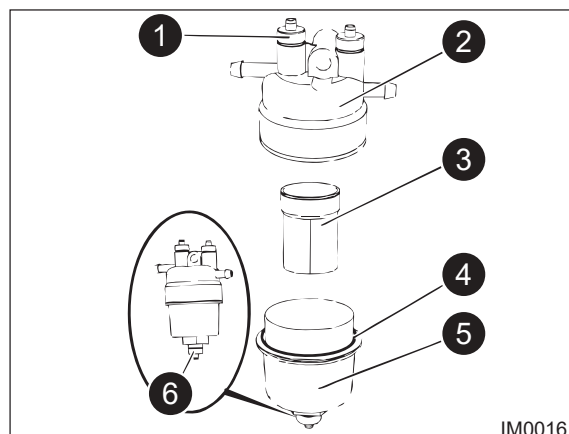

Fig: 11.19 - Water Seperator

5. Open Drain Valve (Item 6) and open Vent Screw (Item 1) and drain the filter. Close drain screw and close vent screw. Use only hand pressure in order to tighten the drain screw and the vent screw. Ref: Fig: 11.19.
6. Remove Filter Bowl (Item 5) from Filter (Item 2) and remove Filter Element (Item 3) from filter. Discard filter element. Ref: Fig: 11.19.
7. Remove O ring seal (Item 4) and discard. Ref: Fig: 11.19.
8. Ensure that all components are clean and dry.
9. Install new O ring seal (Item 4) and install new Filter Element (Item 3). Ref: Fig: 11.19.
10. Install Filter Bowl (Item 5) to Filter (Item 2) and tighten the filter bowl to a torque of 10 Nm (88 lb in). Ref: Fig: 11.19.
11. Remove the container and dispose of the fuel in a safe place.
12. Clean up any spilled fuel.

(c) Fuel System Secondary Filter - Replace**NOTICE**

Do not allow dirt to enter the fuel system. Thoroughly clean the area around a fuel system component that will be disconnected. Fit a suitable cover over disconnected fuel system component.

PROCEDURE

1. Observe all safety warnings.
2. Switch off the engine and implement the lock and tag out.
3. Close the fuel supply valve.
4. Clean the outside of the fuel filter assembly (Item 1, Fig: 11.20).

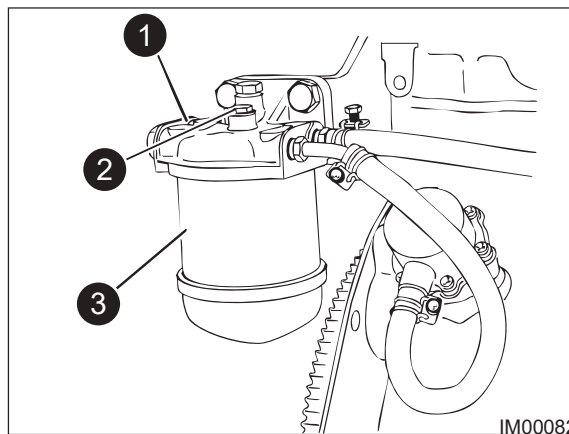

Fig: 11.20 - Fuel Filter

5. Remove setscrew (Item 2, Fig: 11.20).
6. Remove the canister (Item 3, Fig: 11.20). Ensure that any fluid is drained into a suitable container.
7. Assemble the following items (Fig: 11.21): seals (Items 1), seal (Item 2), canister (Item 3) and bowl (Item 4). Place washer (Item 5) and seal (Item 6) on setscrew (Item 7).

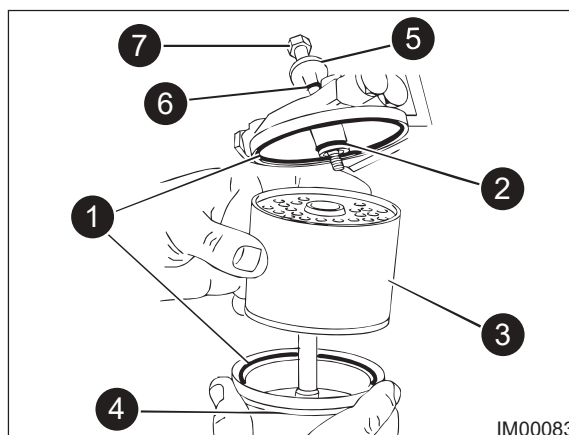

Fig: 11.21 - Fuel Filter Elements

8. Fasten the assembly to the fuel filter base with setscrew (Item 7, Fig: 11.21).
9. Prime the fuel system. Refer to "Fuel System - Prime" on page 11-35.

(d) Fuel System - Prime**NOTICE**

If air enters the fuel system, the air must be purged from the fuel system before the engine can be started. Air can enter the fuel system when the following events occur:

- The fuel tank is empty or the fuel tank has been partially drained.
- The low-pressure fuel lines are disconnected.
- A leak exists in the low-pressure fuel system.
- The fuel filter is replaced.

Ensure that the air is removed from the primary filter before you prime the secondary fuel filter.

PROCEDURE

1. Observe all safety warnings.
2. Switch off the engine and implement the lock and tag out.
3. On the primary filter, open the vent screws (Items 1, Fig: 11.22).

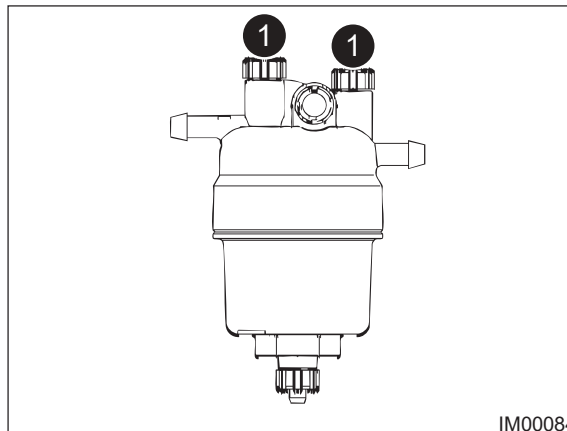

Fig: 11.22 - Primary Filter

4. Operate the hand priming pump (Item 1, Fig: 11.23) until fuel free from air comes from the vent screw. Then close vent screws (Items 1, Fig: 11.22) by hand.

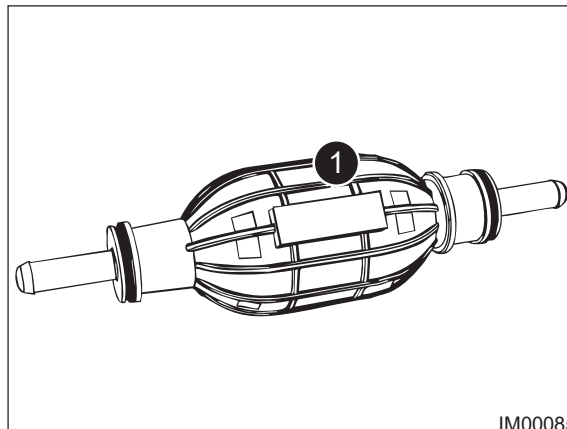

Fig: 11.23 - Priming Pump

5. Loosen vent screw (Item 1, Fig: 11.24) on the fuel filter.

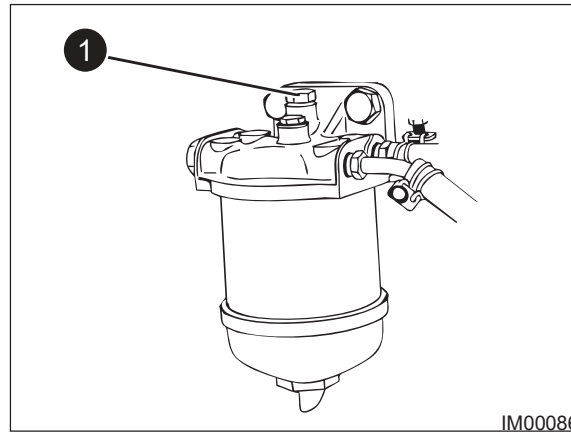

Fig: 11.24 - Vent Screw

6. Operate hand priming pump (Item 1, Fig: 11.23). When fuel free from air flows from the vent screw tighten the vent screw.
7. Loosen the connection (Item 1, Fig: 11.25) at the fuel injection pump.
 - ◇ Fuel return line (Item 2, Fig: 11.25) may need to be removed to prime the fuel system.

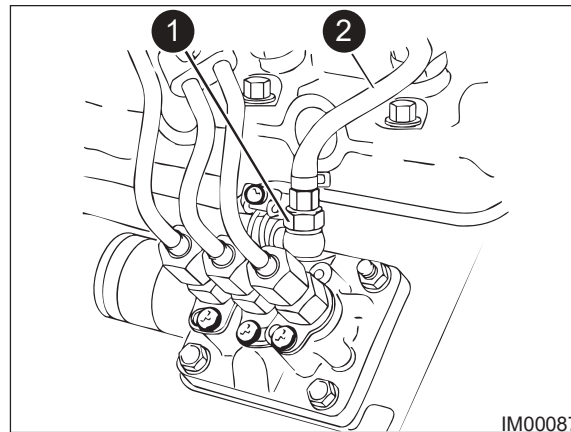

Fig: 11.25 - Injection Pump

8. Operate the hand priming pump (Item 1, Fig: 11.23). When fuel free from air flows from the connections tighten the connecting bolt (Item 1, Fig: 11.25).
9. The engine should now be able to start. Operate the starting motor to start the engine.
 - ◇ Do not operate the starting motor for more than 15 seconds. If the engine does not start after 15 seconds, stop and wait for 30 seconds before trying again.

(e) Refuelling**NOTICE**

For engine related fuel system maintenance, refer to the engine manufacturers handbook for full information regarding schedules and procedures. Engine related procedures outlined in this handbook are for guidance only.

In Europe, the fuel must be sulphur-free according to standard EN 590. It means that the sulphur content must not exceed 10 ppm.

In the USA, the fuel must be an ultra-low sulphur fuel in accordance with standard ASTM D975. It means that the sulphur content cannot exceed 15 ppm.

The fuel system is sensitive to dirt. It is therefore important that everything is as clean as possible when work is carried out on the fuel system.

- Do not use compressed air to blow components in the fuel system clean.
- Use lint-free cloths for cleaning.
- Clean tools before use.
- Do not use worn chrome-plated tools as flakes of chrome can come off.
- Plug or tape connections on components which are removed.

Avoid spillage and use a suitable container. Used fuel shall be disposed of as specified in national and international law.

PROCEDURE

1. Observe all safety warnings.
2. Switch off the engine and implement the lock and tag out.
3. View the sight glass on the side of the fuel tank (Fig: 11.26).

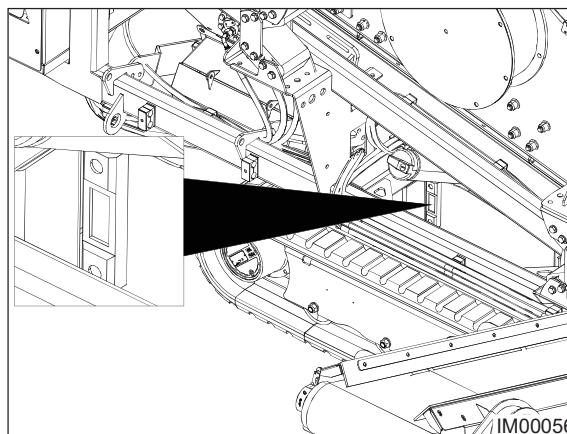

Fig: 11.26 - Sight Glass

4. If top up is required remove the filler cap and fill with correct specification of fuel.
5. Fill the fuel tank at the end of each day, when possible, to reduce overnight condensation within the tank.

(5) Cooling System Coolant (DEAC) - Change**WARNING**

Pressurized System: Hot coolant can cause serious burns. To open the cooling system filler cap, stop the engine and wait until the cooling system components are cool. Loosen the cooling system pressure cap slowly in order to relieve the pressure.

NOTICE

Clean the cooling system and flush the cooling system before the recommended maintenance interval if the following conditions exist:

- The engine overheats frequently.
- Foaming is observed.
- The oil has entered the cooling system and the coolant is contaminated.
- The fuel has entered the cooling system and the coolant is contaminated.

Use of commercially available cooling system cleaners may cause damage to cooling system components. Use only cooling system cleaners that are approved by the engine manufacturer.

Note: Inspect the water pump and the water temperature regulator after the cooling system has been drained. This is a good opportunity to replace the water pump, the water temperature regulator and the hoses, if necessary.

Dispose of used engine coolant properly or recycle. Various methods have been proposed to reclaim used coolant for reuse in engine cooling systems. The full distillation procedure is the only method acceptable by the engine manufacturer to reclaim the used coolant.

(a) Cooling System Coolant Level - Check**PROCEDURE**

1. Observe all safety warnings.
2. Switch off the engine and implement the lock and tag out.
3. Allow the engine to cool.
4. Remove the cooling system filler cap slowly in order to relieve pressure (Fig: 11.27).

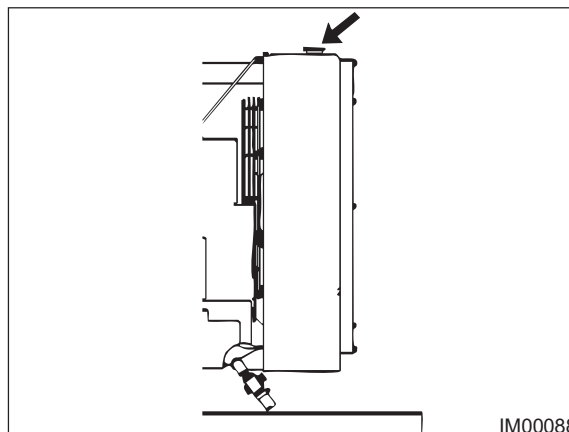

Fig: 11.27 - Filler Cap

5. Maintain the coolant level within 13 mm (0.5 inch) of the bottom of the filler pipe. If the engine is equipped with a sight glass, maintain the coolant level to the proper level in the sight glass.

(b) Drain**PROCEDURE**

1. Observe all safety warnings.
2. Switch off the engine and implement the lock and tag out.
3. Allow the engine to cool.
4. Loosen the cooling system filler cap slowly in order to relieve any pressure. Remove the cooling system filler cap. Refer to engine manufacturers handbook, "General Hazard Information" for information on Containing Fluid Spillage.
5. Open the cooling system drain valve (if equipped). If the cooling system is not equipped with a drain valve, remove one of the drain plugs. Allow the coolant to drain into a suitable container.
6. Properly dispose of the drained material. Obey local regulations for the disposal of the material.

(c) Flush**NOTICE**

Do not fill the cooling system faster than 5 L (1.3 US gal) per minute to avoid air locks.

Cooling system air locks may result in engine damage.

Improper or incomplete rinsing of the cooling system can result in damage to copper and other metal components. To avoid damage to the cooling system, make sure to completely flush the cooling system with clear water. Continue to flush the system until all signs of the cleaning agent are gone.

PROCEDURE

1. Observe all safety warnings.
2. Flush the cooling system with clean water in order to remove any debris.
3. Close the drain valve (if equipped). Clean the drain plugs. Install the drain plugs. Refer to Torque Specifications, SENR3130 for more information on the correct torques.
4. Fill the cooling system with a mixture of clean water and the engine manufacturers Fast Acting Cooling System Cleaner. Add 0.5 L (1 pint) of cleaner per 15 L (4 US gal) of the cooling system capacity. Install the cooling system filler cap.
5. Start and run the engine at low idle for a minimum of 30 minutes. The coolant temperature should be at least 82 °C (180 °F).
6. Stop the engine and allow the engine to cool. Loosen the cooling system filler cap slowly in order to relieve any pressure. Remove the cooling system filler cap. Open the drain valve (if equipped) or remove the cooling system drain plugs. Allow the water to drain. Flush the cooling system with clean water. Close the drain valve (if equipped). Clean the drain plugs. Install the drain plugs. Refer to Torque Specifications, SENR3130 for more information on the correct torques.

(d) Cooling Systems With Heavy Deposits Or Plugging**NOTICE**

Do not fill the cooling system faster than 5 L (1.3 US gal) per minute to avoid air locks.

Cooling system air locks may result in engine damage.

Improper or incomplete rinsing of the cooling system can result in damage to copper and other metal components. To avoid damage to the cooling system, make sure to completely flush the cooling system with clear water. Continue to flush the system until all signs of the cleaning agent are gone.

PROCEDURE

1. Observe all safety warnings.
2. Flush the cooling system with clean water in order to remove any debris.
3. Close the drain valve (if equipped). Clean the drain plugs. Install the drain plugs. Refer to Torque Specifications, SENR3130 for more information on the correct torques.
4. Fill the cooling system with a mixture of clean water and the engine manufacturers Fast Acting Cooling System Cleaner. Add 0.5 L (1 pint) of cleaner per 3.8 to 7.6 L (1 to 2 US gal) of the cooling system capacity. Install the cooling system filler cap.
5. Start and run the engine at low idle for a minimum of 90 minutes. The coolant temperature should be at least 82 °C (180 °F).
6. Stop the engine and allow the engine to cool. Loosen the cooling system filler cap slowly in order to relieve any pressure. Remove the cooling system filler cap. Open the drain valve (if equipped) or remove the cooling system drain plugs. Allow the water to drain. Flush the cooling system with clean water. Close the drain valve (if equipped). Clean the drain plugs. Install the drain plugs. Refer to Torque Specifications, SENR3130 for more information on the correct torques.

(e) Fill**NOTICE**

Do not fill the cooling system faster than 5 L (1.3 US gal) per minute to avoid air locks.

Cooling system air locks may result in engine damage.

PROCEDURE

1. Observe all safety warnings.
2. Fill the cooling system with the coolant/antifreeze. Refer to the engine manufacturers handbook, "Refill Capacities and Recommendations" topic (Maintenance Section) for more information on cooling system specifications. Do not install the cooling system filler cap.
3. Start and run the engine at low idle. Increase the engine rpm to 1500 rpm. Run the engine at high idle for one minute in order to purge the air from the cavities of the engine block. Stop the engine.
4. Check the coolant level. Maintain the coolant level within 13 mm (0.5 inch) below the bottom of the pipe for filling. Maintain the coolant level within 13 mm (0.5 inch) to the proper level on the sight glass (if equipped).

5. Clean the cooling system filler cap. Inspect the gasket that is on the cooling system filler cap. If the gasket that is on the cooling system filler cap is damaged, discard the old cooling system filler cap and install a new cooling system filler cap. If the gasket that is on the cooling system filler cap is not damaged, perform a pressure test. A 9S-8140 pressurizing pump is used to perform the pressure test. The correct pressure for the cooling system filler cap is stamped on the face of the cooling system filler cap. If the cooling system filler cap does not retain the correct pressure, install a new cooling system filler cap.

11.6 Conveyor Maintenance



DANGER

Entanglement Hazard.

Contact with moving conveyor belts will result in serious injury or death.

Stay clear of moving conveyor belts.

Do not operate this machine without all guards and covers in place.

Switch off, lock, and tag out prior to adjusting or servicing the machine.



WARNING

Wear Personal Protective Equipment.

Personal Protective Equipment (PPE) must be worn at all times.

Falling Material Hazard.

Stay clear of the machine when operating. If struck by falling material, death or serious injury can result.

NOTICE

After loading material into the machine, and over time, the belts may require further tensioning or alignment. However, prior to loading the machine for the first time, the belt tension and alignment shall be checked during the set-up process.

Do not over tension conveyor belts. Over tensioned belts cause damage to the drum bearings. If any damage to the conveyor belts has been discovered, do not operate the machine until the issue is resolved or replaced by your local dealer.

When performing belt tensioning on a conveyor it is important that the operator is aware that any underside guards installed are to be checked and adjusted, if necessary, to the 5mm gap requirement. Do not operate the machine if underside guards are touching the belt, damage to the belt will occur.

(1) All Conveyor Belts

(a) Conveyor Daily Checks

PROCEDURE

1. Observe all safety warnings.
2. Switch off the engine and implement the lock and tag out.
3. Regularly check the drums and rollers on the conveyors for any build-up of material.
4. Ensure that all drums and rollers are rotating freely and operating correctly.
5. Check the belts for wear and damage. Repair or replace damaged or worn belts immediately.
6. Check that all skirting rubbers in the feed chutes are pressing lightly onto the belt. Large gaps between the skirting rubbers and the belt will allow excessive spillage.
7. Check all scraper rubbers on the conveyors are set correctly and removing dirt and debris.
8. Ensure correct tension and alignment of the belts.
9. Ensure all roller nip guards are set to the 5mm maximum gap setting.

10. Ensure underside guards are not touching the belt and are set to the 5mm gap setting.
11. Ensure that all bearing lubrication is performed as outlined in the lubrication schedule.
12. Ensure all guards are installed at all times. Never operate the conveyors with guards removed.

(b) Inspect & Clean

PROCEDURE

1. Observe all safety warnings.
2. Ensure all material has been discharged off the belt.
3. Start the engine.
4. Keep the engine rpm at low speed.
5. Turn on the conveyors.
6. At a safe distance observe the conveyor belts and look for any abnormalities on the belts and skirting rubbers. If any abnormalities are discovered, stop the conveyors immediately and carry out the necessary work to repair them.
7. When cleaning the belts, stand at a safe distance, using a power-washer with a good length lance, and take extreme care washing the conveyor belts. Do not lean or reach over the conveyor belts.

(2) Oversize Conveyor**(a) Belt Tensioning****NOTICE**

As long as prescribed maintenance procedures have been properly adhered to, your machine should not experience belt slippage. Slippage is a term used to describe when the belt does not move but the drum rotates. There are a number of reasons why slippage can occur.

Slippage can occur if the belt is incorrectly tensioned, if the belt is worn, lagging is ineffective, rollers cannot rotate freely or there has been too much load on the belt.

PROCEDURE

1. Observe all safety warnings.
2. Switch off the engine and implement the lock and tag out.
3. If the belt is experiencing slippage and material remains on the belt, manually remove the material.
4. Tighten the belt by rotating the adjusters clockwise and evenly, on both sides of the conveyor (Items 1 & 2, Fig: 11.28). It is important to turn each adjuster the same rotation, otherwise, the belt will track off alignment when put into operation. Do not over tighten the belt.

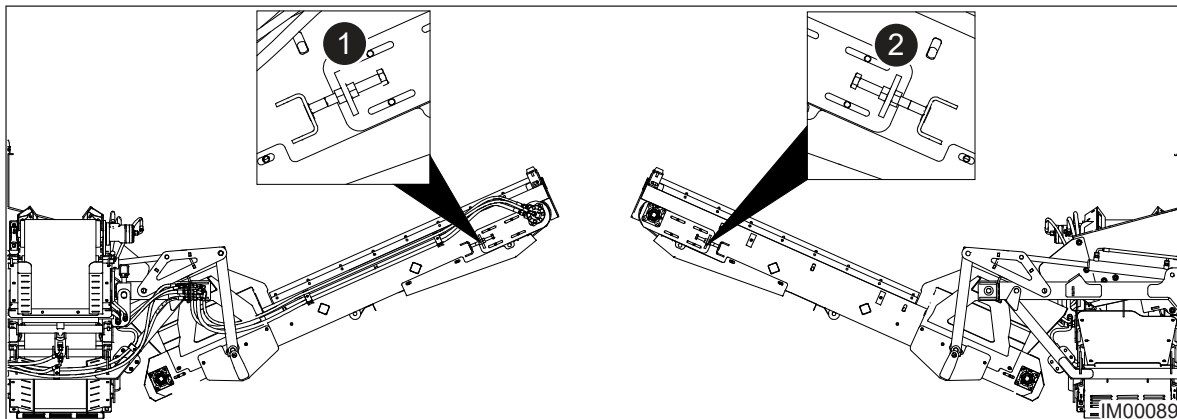

Fig: 11.28 - Belt Adjusters

5. Once the belt has been tensioned, test the belt with material to ensure slippage has stopped.
6. If slippage reoccurs, repeat this procedure.

(b) Belt Alignment**NOTICE**

When performing adjustment on the belt adjusters, do so, in small increments. A small amount of adjustment will move the belt across significantly.

**CAUTION**

Belt alignment is the only procedure permitted with the conveyor belt operating. Extreme caution shall be taken when adjusting the belt adjusters. Stay clear of the belt at all times.

PROCEDURE

1. Observe all safety warnings.
2. Start the engine followed by the conveyor.
3. Observe the conveyor alignment and determine the direction of misalignment.
4. If the conveyor belt is running off to the right side:
 - Use a spanner to rotate the right side adjuster (Item 1, Fig: 11.28) a 1/4 turn (clockwise), then observe the belt alignment. Repeat this step until alignment is satisfactory.
 - If the belt was under too much tension, rotate the left side adjuster (Item 2, Fig: 11.28) a 1/4 turn (counter-clockwise), then observe the belt alignment. Repeat this step until alignment is satisfactory.
5. If the conveyor belt is tracking off to the left side;
 - Use a spanner to rotate the left side adjuster (Item 2, Fig: 11.28) a 1/4 turn (clockwise) then observe the belt alignment. Repeat this step until alignment is satisfactory.
 - Or if the belt would be under too much tension, rotate the right side adjuster (Item 1, Fig: 11.28) - one turn (counter clockwise) then observe the belt alignment. Repeat this step until alignment is satisfactory.

(3) Collection Conveyor**(a) Belt Tensioning****NOTICE**

As long as prescribed maintenance procedures have been properly adhered to, your machine should not experience belt slippage. Slippage is a term used to describe when the belt does not move but the drum rotates. There are a number of reasons why slippage can occur.

Slippage can occur if the belt is incorrectly tensioned, if the belt is worn, lagging is ineffective, rollers cannot rotate freely or there has been too much load on the belt.

PROCEDURE

1. Observe all safety warnings.
2. Switch off the engine and implement the lock and tag out.
3. If the belt is experiencing slippage and material remains on the belt, manually remove the material.
4. Tighten the belt by rotating the adjusters clockwise and evenly, on both sides of the conveyor (Items 1 & 2, Fig: 11.29). It is important to turn each adjuster the same rotation, otherwise, the belt will track off alignment when put into operation. Do not over tighten the belt.

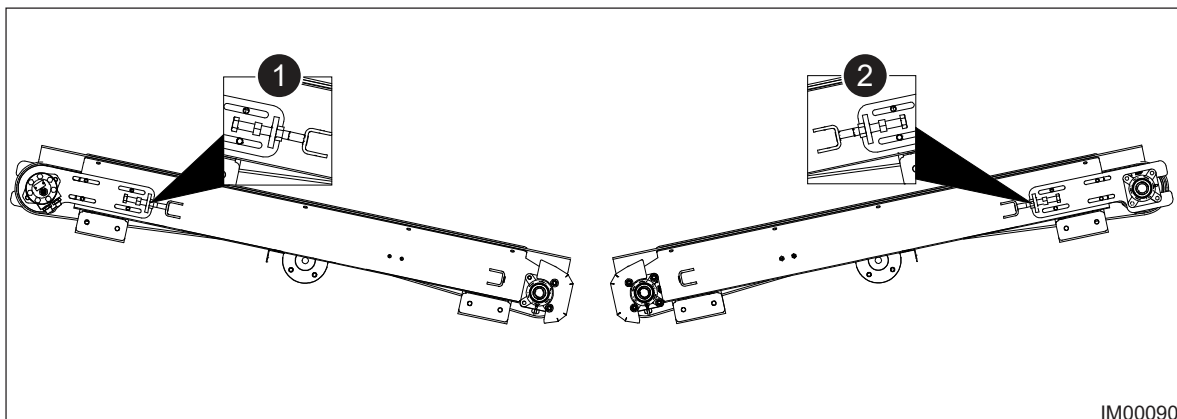

Fig: 11.29 - Belt Adjusters

5. Once the belt has been tensioned, test the belt with material to ensure slippage has stopped.
6. If slippage reoccurs, repeat this procedure.

(b) Belt Alignment**NOTICE**

When performing adjustment on the belt adjusters, do so, in small increments. A small amount of adjustment will move the belt across significantly.

**CAUTION**

Belt alignment is the only procedure permitted with the conveyor belt operating. Extreme caution shall be taken when adjusting the belt adjusters. Stay clear of the belt at all times.

PROCEDURE

1. Observe all safety warnings.
2. Start the engine followed by the conveyor.
3. Observe the conveyor alignment and determine the direction of misalignment.
4. If the conveyor belt is running off to the right side:
 - Use a spanner to rotate the right side adjuster (Item 1, Fig: 11.29) a 1/4 turn (clockwise), then observe the belt alignment. Repeat this step until alignment is satisfactory.
 - If the belt was under too much tension, rotate the left side adjuster (Item 2, Fig: 11.29) a 1/4 turn (counter-clockwise), then observe the belt alignment. Repeat this step until alignment is satisfactory.
5. If the conveyor belt is tracking off to the left side;
 - Use a spanner to rotate the left side adjuster (Item 2, Fig: 11.29) a 1/4 turn (clockwise) then observe the belt alignment. Repeat this step until alignment is satisfactory.
 - Or if the belt would be under too much tension, rotate the right side adjuster (Item 1, Fig: 11.29) - one turn (counter clockwise) then observe the belt alignment. Repeat this step until alignment is satisfactory.

(4) Mid & Fines Size Conveyor**(a) Belt Tensioning****NOTICE**

As long as prescribed maintenance procedures have been properly adhered to, your machine should not experience belt slippage. Slippage is a term used to describe when the belt does not move but the drum rotates. There are a number of reasons why slippage can occur.

Slippage can occur if the belt is incorrectly tensioned, if the belt is worn, lagging is ineffective, rollers cannot rotate freely or there has been too much load on the belt.

PROCEDURE

1. Observe all safety warnings.
2. Switch off the engine and implement the lock and tag out.
3. If the belt is experiencing slippage and material remains on the belt, manually remove the material.
4. Tighten the belt by rotating the adjusters clockwise and evenly, on both sides of the conveyor (Items 1 & 2, Fig: 11.30). It is important to turn each adjuster the same rotation, otherwise, the belt will track off alignment when put into operation. Do not over tighten the belt.

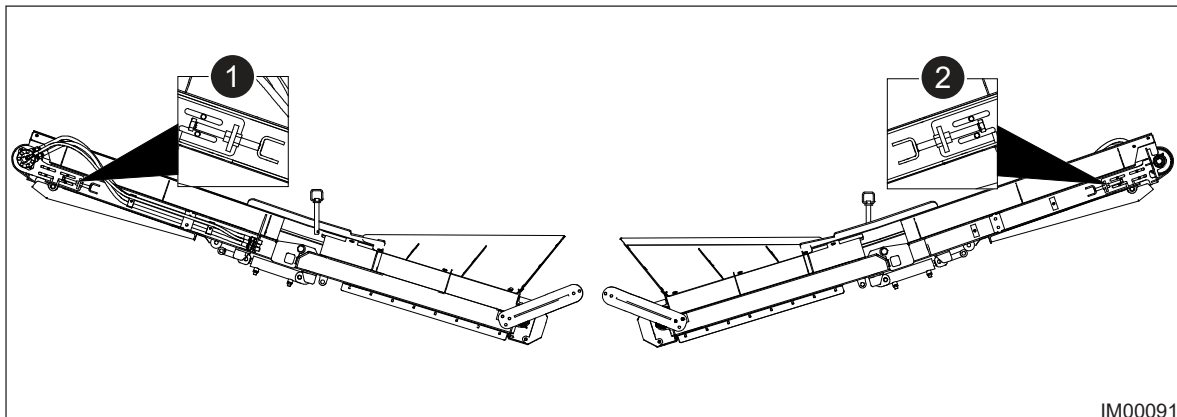

Fig: 11.30 - Belt Adjusters

IM00091

5. Once the belt has been tensioned, test the belt with material to ensure slippage has stopped.
6. If slippage reoccurs, repeat this procedure.

(b) Belt Alignment**NOTICE**

When performing adjustment on the belt adjusters, do so, in small increments. A small amount of adjustment will move the belt across significantly.

**CAUTION**

Belt alignment is the only procedure permitted with the conveyor belt operating. Extreme caution shall be taken when adjusting the belt adjusters. Stay clear of the belt at all times.

PROCEDURE

1. Observe all safety warnings.
2. Start the engine followed by the conveyor.
3. Observe the conveyor alignment and determine the direction of misalignment.
4. If the conveyor belt is running off to the right side:
 - Use a spanner to rotate the right side adjuster (Item 1, Fig: 11.30) a 1/4 turn (clockwise), then observe the belt alignment. Repeat this step until alignment is satisfactory.
 - If the belt was under too much tension, rotate the left side adjuster (Item 2, Fig: 11.30) a 1/4 turn (counter-clockwise), then observe the belt alignment. Repeat this step until alignment is satisfactory.
5. If the conveyor belt is tracking off to the left side;
 - Use a spanner to rotate the left side adjuster (Item 2, Fig: 11.30) a 1/4 turn (clockwise) then observe the belt alignment. Repeat this step until alignment is satisfactory.
 - Or if the belt would be under too much tension, rotate the right side adjuster (Item 1, Fig: 11.30) - one turn (counter clockwise) then observe the belt alignment. Repeat this step until alignment is satisfactory.

11.7 Vibrating Screen Box Maintenance

NOTICE

This machine is dispatched from the factory with the speed of the screen shaft set to 870 rpm with a throw of 9mm. The screen box shaft shall never run over 870 rpm when the stroke is 9mm. The screen box will self destruct in a short period of time.

Depending on the application/material, additional weights can be added to the flywheels on both sides of the screen box. Contact your local dealer or technical support, if the settings require to be adjusted to suit a different application.

(1) Changing Screen Meshes



CAUTION

Pinch Point Hazard.

Caution shall be taken when removing screen meshes. Keep hands clear of potential pinch points.

NOTICE

In most circumstances the top deck mesh will wear quicker than the bottom deck mesh. This procedure shows how to change both at the same time. If only one of the meshes requires to be changed, follow the procedure for the deck required.

PROCEDURE

1. Observe all safety warnings.
2. Switch off the engine and implement the lock and tag out.
3. Remove the mesh tensioner bolts, followed by the tensioners (Items 1, Fig: 11.31) on both sides of the screen box (4 in total).

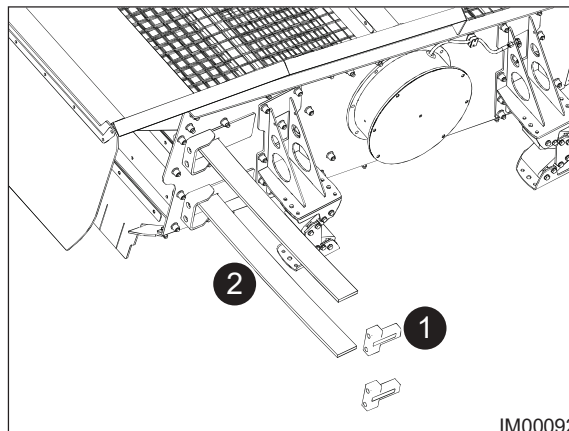

Fig: 11.31 - Tensioners & Camber Bars

4. Remove the camber bars (Items 2). Ref: Fig: 11.31.
5. Slide the old mesh (Item 1, Fig: 11.32) out of the screen box.

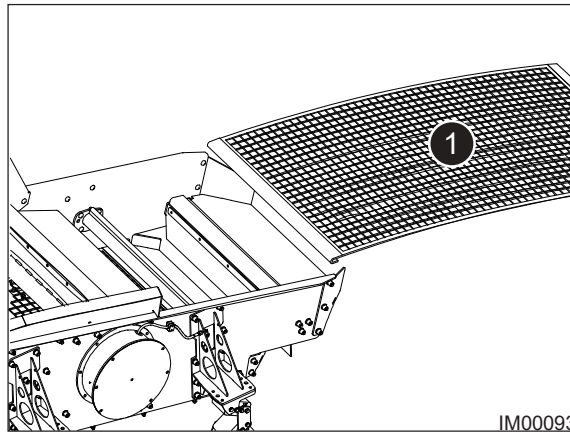

Fig: 11.32 - Mesh Removal

6. Remove the bottom deck mesh using the same process.
7. Clean the screen box by removing any build up of material.
8. Inspect the mesh deck cushion rubbers and replace if necessary.
9. Slide the new mesh deck into the screen box and ensure the holding hook is positioned correctly on the retaining bar (Item 1, Fig: 11.33).

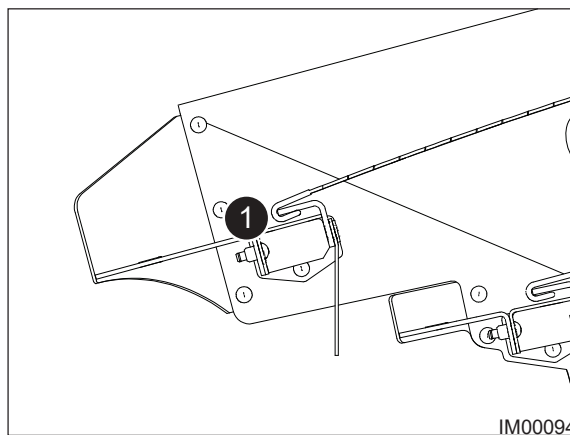

Fig: 11.33 - Retaining Bar

10. Insert camber bars ensuring the curved section of the bar is slotted into the holding hook (Fig: 11.34).

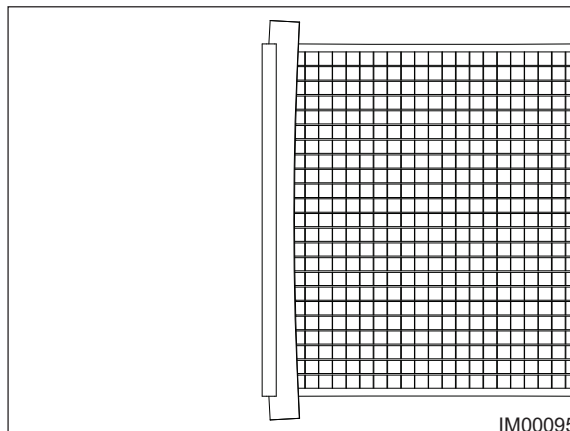

Fig: 11.34 - Camber Bar Position

11. Refit the mesh tensioners (Items 1, Fig: 11.31) and secure with bolts.
12. Tighten tension bolts as required. The centre, of the mesh, tensions first and the appropriate tension is replaced when the outside edges of the mesh are taut. This amount of tension is not always required. Absolute maximum tension is obtained when the screen tension bar is parallel with the hook on the screen mesh.
13. Visually check for vibration in the screen mesh when the screen box is running.

11.8 Hydraulic Oil Tank Maintenance

WARNING

Injection Hazard.

Escaping fluid under pressure can penetrate skin and result in death or serious injury.

Relieve pressure before disconnecting hydraulic lines.

Keep away from leaks and pin holes. Use a piece of cardboard or paper to search for leaks. Do not use hand. Fluid injected into the skin shall be surgically removed within a few hours by a doctor familiar with this type of injury, or gangrene will result.

SAFETY INSTRUCTION

Ensure correct personnel protection equipment is worn when working with the hydraulic system.

NOTICE

Use the correct specification of hydraulic oil, otherwise overheating can occur.

If the hydraulic system requires topping up on a regular basis, inspect all hydraulic components and hoses for leaks. Repairs shall be made prior to continued operation of the machine.

Ensure all dust and debris is cleaned off the oil tank prior to performing any maintenance or service procedures. Contamination in the oil system can lead to increased wear and tear, component failures, and reduced overall performance

(1) Hydraulic Tank Components

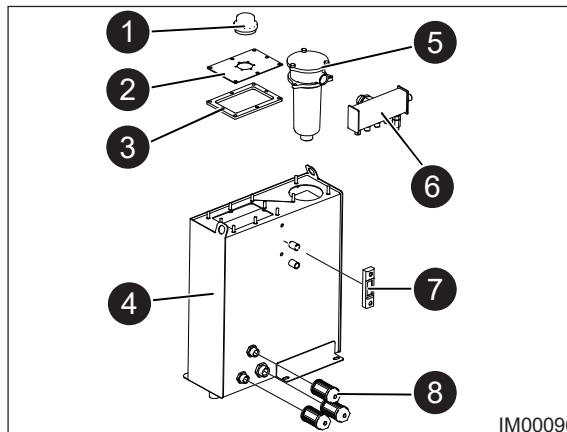
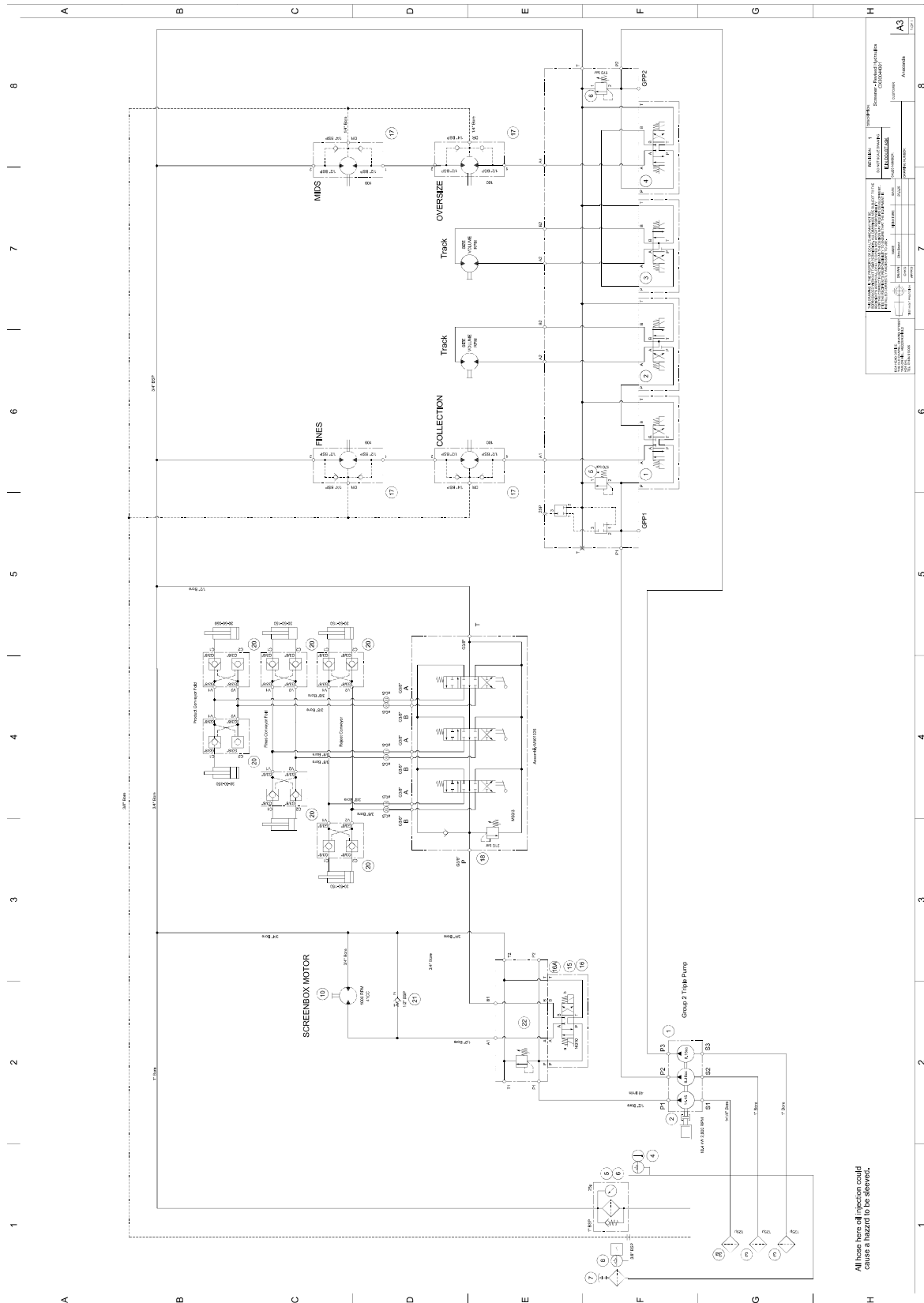

Fig: 11.35 - Hydraulic Tank Components

Item	Component
1	Oil Filler Cap
2	Cover Plate
3	Gasket
4	Oil Tank
5	Return Line Filter (Complete Unit)
6	Hydraulic Manifold
7	Oil Level Gauge
8	Suction Strainers (Inside Tank)

(2) Hydraulic Diagram



<p>REVISIONS</p> <table border="1"> <tr> <th>NO.</th> <th>DATE</th> <th>DESCRIPTION</th> </tr> <tr> <td>1</td> <td>01/15/2025</td> <td>ISSUE 2.1</td> </tr> </table>		NO.	DATE	DESCRIPTION	1	01/15/2025	ISSUE 2.1	<p>DATE: 01/15/2025</p> <p>BY: [Signature]</p> <p>APP: [Signature]</p>
NO.	DATE	DESCRIPTION						
1	01/15/2025	ISSUE 2.1						
<p>PROJECT: RUBBLECRUSHER</p> <p>DRAWING NO: RC-S48</p> <p>SCALE: 1:1</p>		<p>REVISIONS</p> <table border="1"> <tr> <th>NO.</th> <th>DATE</th> <th>DESCRIPTION</th> </tr> <tr> <td>1</td> <td>01/15/2025</td> <td>ISSUE 2.1</td> </tr> </table>	NO.	DATE	DESCRIPTION	1	01/15/2025	ISSUE 2.1
NO.	DATE	DESCRIPTION						
1	01/15/2025	ISSUE 2.1						
<p>APPROVED: [Signature]</p>		<p>DATE: 01/15/2025</p>						

(3) Hydraulic Oil Level

NOTICE

Ensure all hydraulic cylinders are in the closed position to return as much oil possible, back to the hydraulic tank.

Check the oil level when the oil is at operating temperature.

PROCEDURE

1. Observe all safety warnings.
2. Ensure the machine is on a level surface.
3. Gain access to the hydraulic oil tank.
4. View the oil level gauge (Item 1, Fig: 11.36). The oil level shall be between the red and black markers on the sight glass.

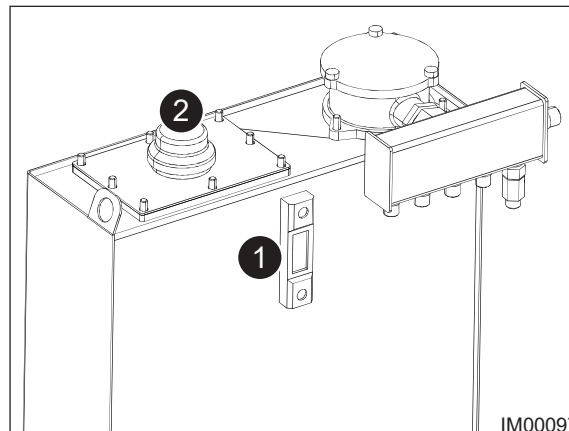

Fig: 11.36 - Hydraulic Oil Tank

5. If necessary remove the filler cap and top up oil. Always use the correct specification of oil. Do not mix oil.

(4) Hydraulic Oil & Suction Stainers Replacement

CAUTION

Burn Hazard.

Tank and oil inside the tank may be hot and can cause bodily injury. Allow to cool before servicing.

NOTICE

Ensure all hydraulic cylinders are in the closed position to return as much oil possible, back to the hydraulic tank.

PROCEDURE

1. Observe all safety warnings.
2. Ensure the machine is on a level surface.
3. Switch off the engine and implement the lock and tag out.
4. Place a suitable container (capable of holding 80 L / 21.1 US Gal) beneath the oil drain plug (Fig: 11.37).

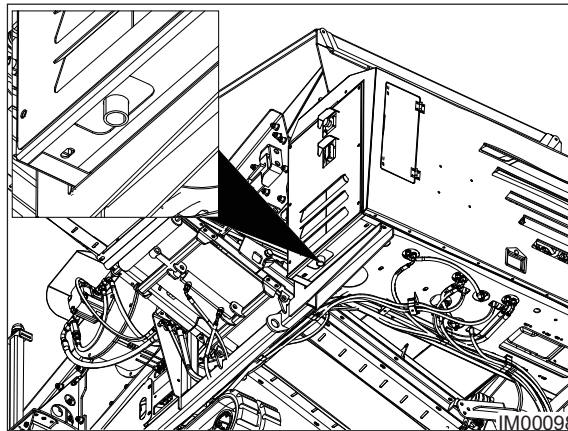

Fig: 11.37 - Oil Drain Plug

5. Remove the inspection cover along with filler cap (Item 1, Fig: 11.38).

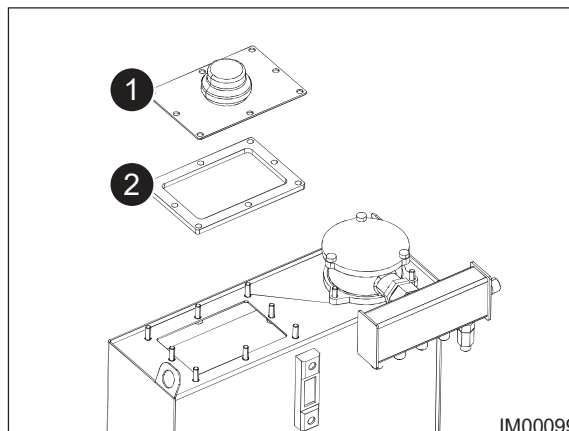

Fig: 11.38 - Inspection Cover

6. Inspect the gasket seal (Item 2, Fig: 11.38) and replace if necessary.

7. Carefully remove the drain plug (Fig: 11.37) and allow the oil to drain to the container. Replace the drain plug seal.
8. Flush the interior of the hydraulic tank with a suitable cleaning liquid that is recommended by the lubricant manufacturer. Drain the cleaning liquid.
9. Replace the suction strainers (Items 1, Fig: 11.39). Rotate each filter counter-clockwise and replace with new filters of same specification.

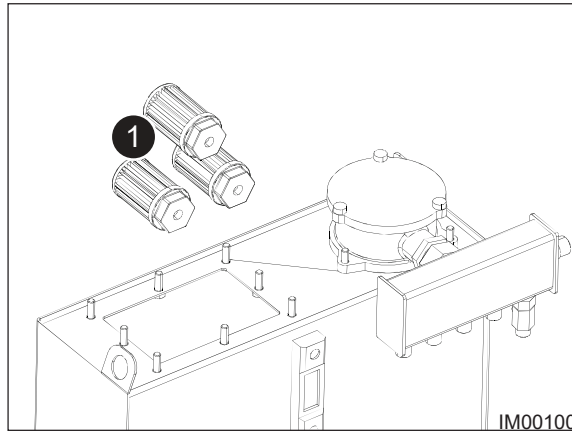

Fig: 11.39 - Suction Strainers

10. Reinstall the drain plug (Fig: 11.37).
11. Install the gasket (Item 2, Fig: 11.38).
12. Install the inspection cover along with filler cap (Item 1, Fig: 11.38).
13. Remove the filler cap and fill the tank with the correct specification of hydraulic oil (80 L / 21.1 US Gal).
14. Dispose of old hydraulic oil and suction strainers according to local regulations and mandates.

(5) Return Line Filter Replacement**CAUTION****Burn Hazard.**

Tank and oil inside the tank may be hot and can cause bodily injury. Allow to cool before servicing.

PROCEDURE

1. Observe all safety warnings.
2. Switch off the engine and implement the lock and tag out.
3. Firmly hold down the filter cover plate and remove the three bolts (Items 1, Fig: 11.40).

◇ *There is a spring under the cover plate which will push the cover plate up.*

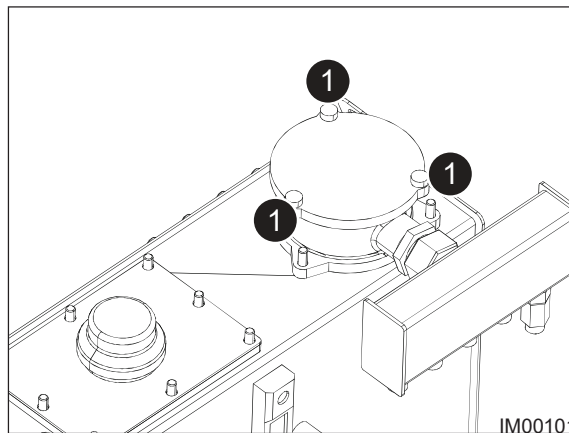

Fig: 11.40 - Return Line Filter Cover Plate

4. Using the pull handles, remove the old filter element.
5. Clean the filter housing using a clean, lint free cloth.
6. Insert the new filter element of correct specification.
7. Install the filter cover plate, along with spring.
8. Secure the cover plate using the 3 securing bolts (Items 1, Fig: 11.40).
9. Dispose of old return line filter according to local regulations and mandates.

11.9 Electrical Maintenance

NOTICE

Disconnect battery ground cable (-) before making adjustments on electrical systems or welding on machine.

Control panels are skillfully manufactured and precise pieces of equipment. Therefore, to ensure that the equipment continually operates effectively the owner should ensure that the following 'good housekeeping' measures are carried out:

- Ensure that only qualified and trained personnel operate and maintain this equipment.
- Electrical connections are susceptible to wet and dirt, therefore, every step shall be taken to avoid such elements affecting this equipment:
- Always keep the control panel access cover closed and locked at all times. Keep the key of the panel in a safe place.
- Regularly check the control panel and all connectors such as battery terminals and solenoid connectors etc for corrosion or build up of dirt.
- When carrying out any repairs ensure that the equipment is kept covered from rain and that all dirt etc, has been cleaned from the equipment.
- Check daily for any damaged or worn gauges, switches, wires or connectors and replace immediately if necessary.
- Never adjust any of the components on this equipment without the authorization of the manufacturer as warranty may be affected where unauthorized adjustments have been.
- Always replace damaged or faulty component parts with compatible replacements.
- Always check ratings before replacement.

If in doubt, do not work on the electrical system of this machine.

(1) Battery Checks

PROCEDURE

1. Observe all safety warnings.
2. Switch off the engine and implement the lock and tag out.
3. Ensure that all electrical connections are clean and tight and coat the terminals with petroleum jelly to protect them from corrosion.

(2) Battery Removal

PROCEDURE

1. Observe all safety warnings.
2. Switch off the engine and implement the lock and tag out.
3. Disconnect the ground (-) lead from the battery (black cable).
4. Disconnect the positive (+) lead from the battery (red cable).
5. Loosen bolts from the battery retaining frame.
6. Remove the battery retaining frame.
7. Remove the battery from the machine.

(3) Battery Installation**PROCEDURE**

1. Observe all safety warnings.
2. Lift the battery into the retaining frame.
3. Fit the battery retaining frame clamp and secure with bolts.
4. Connect the positive (+) lead (red cable).
5. Connect the ground (-) lead (black cable).

11.10 Hydraulic Cylinders - Care Of Chrome Recommendation

NOTICE

All hydraulic cylinders with chrome exposed to the elements must be greased to protect against corrosion.

Chrome-plated rods are normally specified to contain a minimum of 20 – 50 microns of hard chrome-plating. This hard chrome-plating is applied primarily for wear resistance, although it also has considerable corrosion resistance properties.

There are occasions when the rod surface can be exposed to a corrosive environment. This tends to occur when the cylinder is not being used, for example, when the hydraulic cylinders or the equipment onto which they are fitted is being stored or during transportation. In these instances it is best to provide some additional protection to the rod surface.

It is the responsibility of the hydraulic cylinder customer to ensure Care of Chrome Recommendations are adhered to while hydraulic cylinders are in storage pre assembly, and for transportation.

It is the responsibility of the End-User to ensure care of Chrome Recommendations are adhered to during the working life of the hydraulic cylinder.

It is recommend applying solvent-diluted oils such as:

- UNIL – SHX12
- MOTUL – SAF PROTECT LD
- BP – STEMKOR 178

If these oils are not available, then prepare a mixture of 60% oil-based rust-inhibitor and 40% Kerosene.

For New Cylinders

Ensure the hydraulic cylinder is in its storage or transportation position, and clean all dirt or dust using a dry cloth, and apply a thin coating of the solvent diluted oil to all exposed areas of the chrome.

It is recommended that chrome rod is inspected periodically every 4 weeks during storage, and additional solvent-diluted oil applied as required.

For Working Cylinders

It is recommended that all working chrome is inspected periodically as Good Practice; particularly if the equipment is stored and unused for periods of time.

It is important to inspect the rod for any signs of damage, and carefully clean the chrome rod, before applying the solvent-diluted oil.

It is recommended the use of Nitric Solvent (without chlorate) for cleaning of chrome rod.

Throughout the working life of the hydraulic cylinder, it is recommended that the chrome bar is kept clean, and protected against potential damage from falling stones, grinding or welding sparks etc.

The chrome bar should be kept dry, with periodic inspections and application of solvent-diluted oils, especially if hydraulic cylinders or equipment are in storage for any period of time.

11.11 Recommended Bolt Torque Settings

(1) Maximum Bolt Loads And Torque Values (UNC Threads)

UNC	Quality P				S				T				A/F
	in	Newtons	N.m	lbf	lbf.ft	Newtons	N.m	lbf	lbf.ft	Newtons	N.m	lbf	
1/4	4379	5.43	984	4.00	8320	10.3	1870	7.60	8980	11.1	2018	8.19	7/16
5/16	7344	11.2	1650	8.26	13954	21.3	3136	15.71	15061	23.0	3385	16.96	1/2
3/8	10951	19.9	2461	14.68	20807	37.9	5161	27.95	22458	40.9	5048	30.17	9/16
7/16	15065	31.9	3386	23.53	28623	60.7	6434	44.77	30894	65.5	6945	48.31	5/8
1/2	20244	48.8	4551	36.00	38463	92.7	8646	68.37	41516	100	9333	73.76	3/4
9/16	26075	70.4	5861	51.92	49542	134	11137	98.83	53474	144	12021	106	7/8
5/8	32452	97.4	7295	71.84	61658	185	13861	136.45	66552	200	14961	147.5	15/16
3/4	49781	178	11191	131.3	94584	338	21263	249.3	102091	364	22950	268.5	1 1/8
7/8	67157	279	15097	205.8	127599	530	28685	391	137725	572	30961	422	1 5/16
1	88221	418	19832	308.3	167620	795	37682	586	180923	858	40673	633	1 1/2
1 1/8	111007	593	24955	437.4	210913	1126	47415	830	227652	1216	51178	897	1 11/16
1 1/4	142135	837	31953	617.3	270091	1591	60718	1173	291527	1717	65537	1266	1 7/8
1 3/8	168641	1096	37911	808.4	320417	2083	72032	1536	345847	2248	77749	1658	2 1/16
1 1/2	206578	1456	46440	1074	392498	2767	88237	2041	423648	2987	95239	2203	2 1/4

(2) Maximum Bolt Loads And Torque Values (UNF Threads)

UNF	Quality P				S				T				A/F
	in	Newtons	N.m	lbf	lbf.ft	Newtons	N.m	lbf	lbf.ft	Newtons	N.m	lbf	
1/4	5232	6.28	1176	4.63	9941	11.9	2234	8.78	10730	12.9	2412	9.51	7/16
5/16	8410	12.5	1891	9.22	15979	23.8	3592	17.55	17247	25.7	3877	18.96	1/2
3/8	12911	22.7	2903	16.74	24531	43.2	5514	31.9	26478	46.6	5952	34.4	9/16
7/16	17416	35.9	3915	26.5	33091	68.2	7439	50.3	35717	73.6	8029	54.3	5/8
1/2	23685	55.4	5325	40.9	45002	105	10116	77.4	48574	114	10919	84.0	3/4
9/16	30075	79.0	6761	58.3	57143	150	12846	111	61678	162	13865	119	7/8
5/8	38156	111	8578	81.9	72496	210	16297	155	78250	227	17591	167	15/16
3/4	56078	195	12607	144	106549	370	23953	273	115005	399	25854	294	1 1/8
7/8	76297	309	17152	228	144965	587	32589	433	156470	634	35175	468	1 5/16
1	99200	459	22301	339	188480	873	42371	644	203439	942	45734	695	1 1/2
1 1/8	128738	667	28941	492	244602	1267	54988	934	264015	1368	59352	1009	1 11/16
1 1/4	161358	925	36275	682	306580	1757	68921	1296	330911	1896	74391	1398	1 7/8
1 3/8	199331	1252	44811	923	378728	2378	85141	1754	408786	2567	91898	1893	2 1/16
1 1/2	240377	1642	54039	1211	456717	3119	102673	2300	492965	3367	110822	2482	2 1/4

(3) Maximum Bolt Loads And Torque Values (Metric Coarse Threads)

mm	3.6		5.6		6.9		8.8		10.9		12.9		A/F
	Newtons	N.m	Newtons	N.m	Newtons	N.m	Newtons	N.m	Newtons	N.m	Newtons	N.m	
2	284	0.12	378	0.16	731	0.31	863	0.37	1216	0.52	1461	0.63	4
3	726	0.44	966	0.59	1863	1.13	2206	1.34	3109	1.88	3727	2.26	5.5
4	1255	1.00	1677	1.34	3226	2.60	3825	3.04	5374	4.31	6453	5.15	7
5	2059	1.96	2736	2.65	5286	5.10	6257	6.03	8806	8.48	10591	10.20	8
6	2903	3.43	3864	4.51	7453	8.73	8836	10.30	12405	14.71	14906	17.65	10
8	5315	8.24	7090	10.79	13680	21.57	16230	25.50	22751	35.30	27360	42.17	13
10	8473	16.7	11278	21.57	21771	42.17	25791	50.01	36284	70.61	43541	85.32	17
12	12356	28.4	16475	38.25	31773	73.55	37657	87.28	52956	122.60	63547	147.10	19
16	23340	69.6	31087	93.16	60016	178.50	71196	210.80	100027	299.10	120131	357.90	24
20	36481	135	48641	180	93849	384.1	111305	411.9	156415	578.6	187796	696.3	30
24	52563	230	70019	308.9	135331	598.2	160338	711.0	225552	1000	270662	1196	36
30	84043	466	112286	622.7	215745	1206	255952	1422	359902	2010	432471	2403	46
36	123073	814	164261	1089	316753	2099	374612	2481	527595	3491	632526	4197	55
42	169164	1304	225552	1746	435413	3364	515827	3991	725688	5609	870826	6727	65

P,S & T are the Material grade for unified inch and Whitworth fasteners (BS1768 & BS1083)

P = grade UTS of 35 tonf/in² and min. yield of 21 tonf/in², S = grade UTS of 50 tonf/in² and min. yield of 40 tonf/in²,

T = grade UTS of 55 tonf/in² and min. yield of 41 tonf/in²

These torque values are for guidance only! Always check with the equipment/bolt manufacturer.

(4) A Guide To Torque Values

It should be understood that the subject of torque tension loading is beyond the scope of this document. The information here supplied is an acceptable guide for normal conditions; for critical applications, however, further information and research will be necessary.

In preparing this guide to torque values, the following basic assumptions have been made:

- 1 Bolts and nuts are new, standard finish, uncoated and not lubricated*
- 2 The load will be 90% of the bolt yield strength
- 3 The coefficient of friction (μ) is 0.14
- 4 The final tightening sequence is achieved smoothly and slowly, until the torque tool indicates full torque has been obtained.

If lubrication has been applied to the bolt and/or the nut (other than the normal protective oil film), multiply the recommended torque by the appropriate factor shown in the table.

Example: bolt and nut are both phosphated; required torque = torque recommended x 0.75.

		Surface Condition Of Bolt			
		Self	Zinc	Cadmium	Phosphate
Surface condition of nut	Self	1.00	1.00	0.80	0.90
	Zinc	1.15	1.20	1.35	1.15
	Cadmium	0.85	0.90	1.20	1.00
	Phosphate and oil	0.70	0.65	0.70	0.75
	Zinc with wax	0.60	0.55	0.65	0.55

Accepted formulae relating torque and tension, based on many tests are:

$M = \frac{P \times D}{60}$	M = torque lbf.ft P = bolt tension lbf D = bolt dia.ins
-----------------------------	---

Or for metric sizes:

$M = \frac{P \times D}{5000}$	M = torque N.m P = bolt tension Newtons D = bolt dia. mm
-------------------------------	--

Table of Content

12	Troubleshooting.....	12-2
12.1	General Trouble Shooting	12-2
12.2	Electrical Trouble Shooting.....	12-5
12.3	Hydraulic Trouble Shooting	12-6
12.4	Crawler Track Troubleshooting	12-7
	(1) Track Tension.....	12-7
	(2) Loss Of Drive	12-8
12.5	Radio Remote Troubleshooting.....	12-9
12.6	Conveyor Belt Troubleshooting.....	12-10

12 Troubleshooting

NOTICE

Refer to the engine manufacturers handbook for all engine related trouble shooting procedures.

12.1 General Trouble Shooting

FAULT	CAUSE	CORRECT MEASURE
Drive drum turns but belt does not move	Too much load on belt. Incorrectly tensioned belt. Worn belt/worn lagging.	Reduce load on belt. Tension belt. Replace belt/replace lagging or drum.
Belt completely stopped	Material jam. Taper lock/ coupling is not tight or broken.	Remove material jam. Tighten or replace taper lock/ coupling.
Belt tracking off to one side or the other	Belt needs aligned. Machine not on level ground.	Align belt. Level the ground under machine.
Material collecting under belt	Skirting rubber needs adjusted or replaced. Belt tension.	Adjust or replace rubber. Belt adjust.
Unusual noise from bearing	Bearing needs lubricant. Bearing not aligned properly. Damaged bearing.	Follow greasing procedure. Align bearing. Replace bearing.
Belt is screeching	Conveyor belt rubbing against frame or other parts. Belt scraper too tight.	Remove any obstruction, adjust and align belt. Adjust scraper.
Excessive noise at pump	Blockage at pre pump filter. Misalignment between drive source and pump. Incorrect hydraulic oil. Obstruction at inlet price.	Replace suction filter. Align drive source to pump. Drain hydraulic oil and replace. Remove obstruction.
Machine components running slowly	Material obstructing component. Oil leak. Low engine speed. Low hydraulic oil. Return line filter blocked Pre-pump filter blocked. Material overload on component. Control valve relief valve. Pump cavitation- suction line. Flow at pump incorrect.	Clear obstruction. Repair leak. Set engine speed to correct level. Top up hydraulic oil level. Replace return line filter. Replace suction filter. Remove material. Check pressure and set correctly. Open gate valve. Check flows elsewhere and reset.

FAULT	CAUSE	CORRECT MEASURE
Machine operating slowly but no sign of external oil leaks	Low hydraulic oil level. Incorrect hydraulic oil. Engine performance. Loose or damaged taper locks. Worn or damaged drive motor. Worn or damaged pump.	Top up hydraulic oil. Drain tank and replace oil. Refer to engine manual. Tighten/.replace taper lock. Replace motor. Replace pump.
Low hydraulic oil pressure	Contaminants in oil. Worn or sticking relief valve. Dirt holding valve partially open. Control valve relief value pressure set too low.	Drain tank and replace oil. Replace relief valve. Clean around valve or replace. Adjust pressure to correct level.
No response from any hydraulic system	Low hydraulic oil level. Return line element is blocked. Damaged suction line. Pressure relief valve stuck in open position.	Top up hydraulic oil level. Replace return line element. Replace suction line pipe. Replace valve.
Vibration in screen box subframe	Build up of material. Anti rock stays have not been removed. Meshes loose. Machine not level. Screen shaft speed incorrect. Flywheels are not aligned. Screen box not tuned properly. Bearing failure. Overload of material.	Remove build up. Remove anti rock stays. Tighten meshes. Level ground under machine. Reset shaft speed. Align flywheels with scribe line. Add or remove weights to tune screen box. Replace bearing. Avoid overloading machine.
Tracks do not work	Control bank levers are not engaged to operate tracks.	Engage Levers.
Decks blinded with clay	Wire cloth wire too heavy.	Use smaller- gauge wire.
Rock moves across screen too fast	RPM too high. Stroke angle too high.	Decrease RPM but stay within stroke speed range. Decrease stroke angle.
Rock moves across screen too slowly	RPM too low. Stroke angle too flat.	"Increase rpm but stay within stroke speed range Increase stoke angle."

FAULT	CAUSE	CORRECT MEASURE
Machine components running slowly	Obstruction (e.g stone, material build up etc). Check general condition of machine (e.g oil leaks, excessive heat, hose blockages etc). Low engine speed. Machine is overloaded. Incorrect control valve relief valve pressure settings. Flow at pump is not as expected. Pump cavitation, suction line is collapsed. Return line filter blockage. Pre- pump filter blockage.	Clear obstruction. Correct problem if possible. Correct engine speed. Check mesh size calculations. Check flow after pump, after control valve and after motor. These valves should be the same. Open gate valve. Low oil level. Replace return line filter. Replace suction strainer.

12.2 Electrical Trouble Shooting

FAULT	CAUSE	CORRECT MEASURE
Warning siren not working	Fuse blown. Siren damaged.	Replace fuse. Replace siren.
Control panel lights up but engine does not start	Emergency stop pressed in. Emergency stop wiring fault. Low engine oil. Faulty start motor relay. Faulty starter motor. Faulty ignition switch.	Depress all e-stops. Check wiring on all e-stops. Top up engine oil. Replace start motor. Replace ignition switch.
Control panel does not light up	"Low battery voltage. Fuse blown. Faulty ignition switch terminals. Battery damaged.	Charge battery. Replace fuse. Check connections/replace. Replace battery.
Battery goes flat when engine is running	Low battery voltage. Fuse blown. Faulty starter motor relay. Faulty starter motor. Alternator not charging.	Charge battery. Replace fuse. Replace relay. Replace starter motor. Check alternator is charging.
Tracks remote control does not work	Battery pack not charged. Changeover switch not engaged. Check if connection plug connected.	Change battery pack. Engage changeover switch. Check connection plug.
Tracks do not work	Fuse blown.	Replace fuse and check circuit.

12.3 Hydraulic Trouble Shooting

FAULT	CAUSE	CORRECT MEASURE
No response from any hydraulic function	Low oil level. Return line element clogged. Damaged suction line. Pressure relief valve stuck in open position.	Top up hydraulic oil level (Check blockage indicator if fitted). Replace return line element. Replace suction line pipe. Replace valve.
Machine operating slowly. No external oil leaks	Low oil level. Incorrect hydraulic oil. Engine performance. Loose or damaged taper locks. Worn or damaged drive motor. Worn or damaged pump"	Top up hydraulic oil level. Drain tank and replace. Consult engine manual. Tighten/replace taper lock. Replace motor. Replace pump.
Excessive noise from hydraulic pump	Low oil level causing cavitation. Incorrect hydraulic oil. Damage to suction pipe. Misaligned drive (engine/motor source). Damaged pump.	Top up oil level. Drain tank and replace. Replace pipe. Align pump correctly. Replace pump.

12.4 Crawler Track Troubleshooting

NOTICE

Refer to the crawler track manufacturers handbook for all related troubleshooting procedures.

(1) Track Tension

Track systems use a grease cylinder to keep the track chains in tension. Loss of tension in the tracks can result in the sprocket jumping in the belt lugs, and also allows the belt to run off of the idler/sprocket. This can hinder the tracking ability of the machine and damage many of the components of the track systems if not resolved quickly.

The tension of the tracks should be checked on a regular basis according to the parameters set out in "Checking Track Tension" on page 11-17 of this handbook. If the tension of the track is outside these parameters, and the adjustment method given in "Adjustment Of Track Tension" on page 11-18 has no effect, please read below checks that can be made to identify possible causes:

Check 1:

With the tensioner access plate removed, make a visual inspection of the greaser, looking for any signs of leaking grease.

Possible Cause:

If grease is leaking from the base of the greaser; where it screws into the end of the tensioner; either the gasket has failed and needs replacing, or the greaser is not screwed in properly and needs tightening.

If grease is leaking from the end of the greaser where the grease gun connects to it, the greaser valve has failed and should be replaced.

Check 2:

When the machine is stationary and blocked, make a visual inspection of the belt below the adjusting end of the tensioner, looking for any signs of leaking grease.

Also, reach under the frame, feel the adjusting end of the tensioner for any grease.

Possible Cause:

If grease is leaking from the adjusting end of the cylinder, the seals may have failed. This requires the tensioner to be removed from the track frame and replacing with a new unit.

If the above checks have been carried out with no signs of any faults, please contact the help line for further assistance.

(2) Loss Of Drive

Rubber track systems are driven using hydraulic motors connected to planetary drive gearboxes. The hydraulic motors are driven using the hydraulics fitted to the machine.

Begin by making a visual inspection of the tracks, particularly around the sprocket, idler and bottom rollers where material / objects can sometimes lodge. Follow this by inspecting all hoses and connections, ensuring there are no leaks or blocks. If there are no physical impedances in the tracks and no faults are found with hoses and connectors, please read below checks that can be made and possible causes:

Check 1:

Using pressure / flow testing equipment, measure the values of flow and pressure being applied to the hydraulic motors.

Possible Cause:

If the values of flow and pressure passing to the hydraulic motors is less than that required to drive the tracks (see machine manufacturer's separate publication), there may be a fault in the machine hydraulic system.

Check 2:

Test the hydraulic pressure being applied to the brake release port on the gearbox. In order to release the brake, this should be fed with a pressure of between 12 and 50 bar.

Possible Cause:

If the pressure is below 12 bar, do not attempt to drive the tracks. With a pressure below 12 bar, the brake will not release when attempting to drive the tracks. This can cause the brakes to seize requiring a replacement unit to be fitted.

Check 3:

If a valve is fitted to the hydraulic motor flange, ensure there are no visible faults with the valve, and none of the connections are damaged / leaking.

Possible Cause:

If there are no visual faults with the valve, and all other checks fail to identify any faults, the valve block may need replacing.

If the above checks have been carried out with no signs of any faults, please contact the help line for further assistance.

12.5 Radio Remote Troubleshooting

FAULT 1

Machine is not tracking on radio remote handset.

ACTION

- Ensure radio remote handset is switched on.
- Ensure the radio receiver is not disconnected.
- Ensure track switch is in TRACK position.
- Ensure the radio remote handset is fully charged.
- Handset is paired with the receiver.

FAULT -1

Machine is not tracking in a straight line.

ACTION

- Ensure the tracks are not obstructed.
- Ensure track switch is in TRACK position.

FAULT - 2

Conveyors and Screen start/stop on radio remote handset not working.

ACTION

- Ensure radio remote handset is switched on.
- Ensure the radio receiver is not disconnected.
- Ensure the radio remote handset is fully charged.
- Handset is paired with the receiver.

12.6 Conveyor Belt Troubleshooting

FAULT 1

Drum turns but the belt does not move.

ACTION/CAUSE

Too much load on the belt - remove the load.

Rollers cannot rotate freely - clean/check replace rollers.

Drum lagging.

FAULT 2

Belt stops all together.

ACTION/CAUSE

Material jam - remove material jam.

FAULT 3

Belt is 'tracking off' to the right.

ACTION/CAUSE

Machine not levelled - level machine.

Belt is not aligned - Tension the belt on the right.

FAULT 4

Belt is 'tracking off' to the left.

ACTION/CAUSE

Machine not levelled - level machine.

Belt is not aligned - Tension the belt on the left.

FAULT 5

Material collects under the belt.

ACTION/CAUSE

Skirting rubbers not adjusted - Adjust skirting rubbers.

Check belt tension.

FAULT 6

A screeching noise is heard when conveyor is running.

ACTION/CAUSE

Belt scraper too tightly placed against belt - Re adjust belt scraper.

Table of Content

13 Decommissioning The Machine 13-2

13 Decommissioning The Machine

Danger

Risk of death or serious injury from fire and explosion while working with mechanical and flame cutting tools.

- Local safety regulations and mandates are to be observed at all times.
- The work location selected will be carefully chosen so that you or any other personnel are never put at risk.
- Observe all local regulations and mandates regarding storage of gases (explosion prevention).

WARNING

Risk of serious injury or death due to unexpected movement of machine components during de-commissioning.

The machine will lose stability during dismantling and unexpected movements shall occur.

- Handle the equipment with extreme caution when dismantling. Always be prepared for unexpected movement and have a safe exit plan prior to performing any tasks.
- Correct personal protective equipment shall be worn at all times. No exceptions.

CAUTION

Danger due to falling materials such as rock, concrete, metal parts, etc. that have become lodged in recesses on the machine during its operating life. These materials can fall out unexpectedly when dismantling.

- Handle all equipment cautiously during dismantling.
- Correct personal protective equipment shall be worn at all times. No exceptions.

A full and thorough risk assessment shall be performed with extreme caution prior to disassembling this machine. All potential hazards shall be addressed and the correct safety measures implemented.

NOTICE

This section describes de-commissioning the machine for the last time and disposal of the entire machine.

The machine shall only be dismantled by authorised, specialist, companies who are familiar with this type of equipment.

All components (hydraulic cylinders, steel components, conveyor belts, electrical components, etc.) as well as utilities are to be disposed of professionally and in accordance with the relevant national laws.

- Correct personal protective equipment shall be worn at all times. No exceptions.
- During dismantling of the machine, use suitable rated lifting equipment that has been approved and tested for this application. Ensure all equipment used has a sufficient, safe working load.

Table of Content

14	Warranty.....	14-2
14.1	Warranty Period and Machine Registration.....	14-2
	(1) Warranty Period.....	14-2
	(2) Machine Registration.....	14-2
	(3) Engines Shall Be Registered With Local Dealers.....	14-2
	(4) Parts Shall Be Recommended.....	14-2
14.2	Rubblecrusher’s Responsibilities.....	14-3
14.3	Rubblecrusher’s Non Responsibility.....	14-3
14.4	Rubblecrusher Limited Product Warranties And Conditions.....	14-4

14 Warranty

14.1 Warranty Period and Machine Registration

(1) Warranty Period

RUBBLECRUSHER (hereafter referred to as “seller”) warrants its new equipment and parts manufactured and sold worldwide to be free, under normal use, service and maintenance, of any defects in manufacture or materials for a period of 24 months from the date the equipment is first put to work or 2000 hours (whichever comes first). The seller must be notified in writing within 60 days of any defect and the Buyer must confirm that (1) the equipment has been properly serviced and (2) inspected at all times and that (3) the equipment has been operating under normal working conditions.

The Buyer must confirm that the defect was in no way caused by negligent or intentional action by the Buyer, its agents or employees.

If it is found, following an investigation into the alleged defect, that the defect was not caused by the seller or that the conditions (1), (2) or (3) above have not been met, then this warranty shall not cover the alleged defect.

(2) Machine Registration

Your RUBBLECRUSHER product must be registered for warranty.

Please complete the Commissioning and Warranty Registration Certificate (CWR).

A copy must be retained by customer & original returned to RUBBLECRUSHER.

No warranty claim will be accepted by RUBBLECRUSHER unless the factory has a (CWR) form on file for each machine.

(3) Engines Shall Be Registered With Local Dealers

This warranty does not apply to engines sold for use in RUBBLECRUSHER products. Engines are covered by their own brand manufacture warranties, for eg. CAT. Important – Your (for eg. CAT) engine must be registered for warranty with your local (for eg. CAT) dealer. Failure to do so will result in extensive delays and frustration while cover is established.

(4) Parts Shall Be Recommended

This warranty shall be null and void if parts, including wear parts, other than genuine OEM seller parts are used in the equipment. Accessories, assemblies and components included in the seller equipment, which are not manufactured by the seller, are subject to the warranty of their respective manufacturers.

Normal maintenance, adjustment or maintenance/wear parts, including, without limitation, proper tightening of bolts, nuts, pipe fittings, adding or replacing of fluids, filters, belts, rubber skirting, feedboot linings and paint, are not covered by this warranty are the sole maintenance responsibility of the Buyer.

Warranty excludes the carriage of any parts that are on the recommended list of stock to or from the machine. It is the buyers sole responsibility to stock a list of parts to support the machines in their territory.

14.2 Rubblecrusher's Responsibilities

Seller's obligation and liability under this warranty is expressly limited to, at seller's sole option, repairing or replacing any part which appears to seller upon inspection to have been defective in material or workmanship. Such parts shall be provided at no cost to the owner. If requested by the seller, components or parts for which a warranty claim is made shall be returned to the seller at a location designated by the seller.

All components and parts replaced under this limited product warranty become the property of the seller.

If a defect in workmanship or material is found during the standard warranty period RUBBLECRUSHER will:

- Provide (at RUBBLECRUSHER's choice) a new, re-manufactured or RUBBLECRUSHER-approved repaired parts or assembled components needed to correct the defect.

Note: Items replaced under this warranty become the property of RUBBLECRUSHER.

- Provide customary or reasonable labour needed to correct the defect.
- All warranty claims will be settled within a 90 day review period. Where approved, parts will be shipped free of charge and agreed hours worked will be paid.
- Purchase order numbers must be provided for any parts and if found to be warranty, invoice will be credited.
- Warranty excludes the carriage of any parts. It is the buyers sole responsibility to stock a list of parts to support the machines in their territory.
- All warranty claims will be settled within a 90 day review period. Where approved, the parts and agreed hours worked will be paid/credited.

14.3 Rubblecrusher's Non Responsibility

- Failures resulting from unauthorized adjustments or repair, and unauthorized setting changes.
- Failures resulting from neglect, abuse, and/or improper repair.
- Failures resulting from user's delay in making the product available after being notified of a potential product problem.
- Failures resulting from any use or installation which RUBBLECRUSHER judges improper.
- Failures resulting from attachments, accessory items and parts not sold or approved by RUBBLECRUSHER.
- Damage to fixtures, attachments, parts and accessory items, which are not part of the machine.
- RUBBLECRUSHER accepts no responsibility for any downtime in production during warranty breakdown situation and will not cover any costs/loss of earnings as a result of this breakdown other than the cost of replacing any parts and labour charges in relation to the repair of the machine.
- RUBBLECRUSHER does not cover food / accommodation / car hire or any travel costs other than time and mileage.

14.4 Rubblecrusher Limited Product Warranties And Conditions

Whilst RUBBLECRUSHER shall make every endeavour to use the best materials available, no liability is accepted by the RUBBLECRUSHER for loss, damage or injury to property or person arising directly from any failure or defect in the machinery or equipment supplied.

RUBBLECRUSHER at its discretion undertakes to replace or repair free of cost, any part or parts supplied by it direct to the Customer of which it will receive written notice, and which shall be proved to the satisfaction of the RUBBLECRUSHER to be defective in either materials or workmanship.

- That prompt written notice of complaint is given to the RUBBLECRUSHER of the discovery of the defect.
- Any part, if replaced, shall become the property of the RUBBLECRUSHER.
- No unauthorized alteration or modification has been made to the plant or machine or component subject to claim.

Technical Specifications

Details, dimensions and statements to the suitability of machinery for any particular purpose or as to the capacity, type specified or contained in any drawings, quotations, catalogues, shipping or other technical specifications etc. Any illustrations or photographs referred to, though carefully given, are not intended as and must not be treated as the contractual description.

Sites and Foundations

RUBBLECRUSHER undertakes no responsibility for sites or foundations or for any framework or support for machinery or for compliance with any local by-law or statutory regulations, or for the fulfilment of any special requirements that the Customer may be bound to observe or fulfil. The Customer shall be responsible for the proper adoption of any designs to his own circumstances. As part of the warranty claim evaluation, working conditions will be taken into account. Where it is found that the equipment has been working in 'unusual' conditions or outside recommended applications/ tonnages/material piece size, the claim will be deemed invalid and immediately refused.

Insurance

The Customer shall keep the goods fully insured.

Users to read and follow Instructions

It is the operator's responsibility to read, understand and apply the instructions given in the RUBBLECRUSHER Operation & Maintenance (O & M) guide supplied with the product.

The user of the RUBBLECRUSHER product is expected to follow all instructions, periodically checking the machine and the work as it progresses.

Unloading and Shipping

All unloading shall be at the risk of and expense of the customer. All shipping delays, shipping charges or any description, after the company has fulfilled its obligation (if appropriate) to deliver, shall be at the customers expense. Any damage caused by carrier handling is a transportation claim and should be fixed immediately with the respective carrier:

Local Requirements

To the best of the RUBBLECRUSHER's knowledge the machinery and plant manufactured by RUBBLECRUSHER complies with the requirements imposed on a manufacturer. Should special or additional items be required to meet the particular local requirements of the Customer they will be charged as additional items.

Machine Commissioning

Where RUBBLECRUSHER's sale includes commissioning, the company accepts no contractual obligation in respect of provision of work or materials for the preparation of a proper site with sufficient and suitable access thereto. The Customer shall be responsible for and bound to provide at his own expense:

- A properly prepared site, with suitable foundations and adequate access;
- All necessary lifting tackle, fuel, water, oil and other stores, and;
- Sufficient labour and assistance to enable RUBBLECRUSHER to proceed properly with and complete the erection of and the starting and setting to work of the machinery.

If the customer shall require training for his personnel he shall provide operators of acceptable calibre and physical capability to RUBBLECRUSHER who shall provide suitable training at the Customer's expense. If necessary an interpreter shall be made available at the customer's expense.

The customer shall indemnify RUBBLECRUSHER against any claims, damages, costs and expenses in respect of any accident, injury or loss sustained by personnel recruited by the Customer and arising of and in the personnel effect the necessary employer's liability insurance in respect of them.

Equipment Design May Change

RUBBLECRUSHER reserves the right to make changes in construction or in design of equipment and components without obligation, and to incorporate such changes in equipment and components previously ordered.

User Responsibilities

The user is responsible for:

- Providing proof of the delivery date to the first user.
- Giving timely notice of a warrantable failure and promptly making the product available for repair.

Improper Use

Improper maintenance, improper use, abuse, improper storage, operation beyond rated capacity, operation after discovery of defective or worn parts, sabotage or alteration or repair of the equipment by persons not authorised by the seller shall render this warranty null and void. Seller reserves the right to inspect the equipment at any time to determine if any failure was due to improper maintenance, improper use, abuse, improper storage, operation beyond rated capacity, operation after discovery of defective or worn parts, sabotage or alteration or repair of the equipment by unauthorized persons.

Operation After Noted Failure

Should the owner or operator continue to operate a machine after it has been noted that a failure has occurred, the seller will not be responsible under the warranty terms for resultant damage to any other parts due to that continued operation.

Breach of Warranty

IN THE EVENT OF ANY BREACH OF THE WARRANTY BY THE SELLER, SELLER'S LIABILITIES SHALL BE LIMITED EXCLUSIVELY TO THE REMEDIES (AT SELLERS SOLE OPTION) OF REPAIR OR REPLACEMENT OF ANY DEFECTIVE PART COVERED BY THE WARRANTY. THE SELLER SHALL NOT BE LIABLE FOR ANY INCIDENTAL OR CONSEQUENTIAL DAMAGES OF ANY KIND, INCLUDING, BUT NOT LIMITED TO, LOST PROFITS, LOSS OF PRODUCTION, INCREASED OVERHEAD, LOSS OF BUSINESS OPPORTUNITY, DELAYS IN PRODUCTION, HIRE CHARGES, DOWNTIME, THIRD PARTY REPAIRS, LOSS OF CONTRACT, COSTS OF REPLACEMENT PARTS AND INCREASED COSTS OF OPERATION THAT MAY ARISE FROM THE BREACH OF WARRANTY.

This warranty is expressly in lieu of and excludes all other warranties, representations and conditions, expressed or implied and all other statutory, contractual, tortuous and common law obligations or liability on Seller's part are hereby expressly excluded to the maximum extent permitted by law. There are no warranties that extend beyond the limited warranty contained herein.

Filing a Warranty Claim

- 1 A copy of a (CWR) Commissioning Warranty Registration Cert must be on file with RUBBLECRUSHER factory before a warranty claim will be considered. A Commissioning Cert file must be submitted and completed on machine startup.
- 2 A claim should not be submitted until the machine is fully repaired.
- 3 Warranty Travel and Mileage will be at a rate agreed with prior RUBBLECRUSHER manufacturer's approval. Labour rates are fixed and are paid at a rate per hour worked – hours worked will be approved by RUBBLECRUSHER Equipment (this decision will be based on what is deemed 'reasonable hours worked' to replace/repair parts/equipment). Mileage is capped at 200 mile to or from site, i.e total 400 mile per job.
- 4 Any replacement parts must be those recommended by RUBBLECRUSHER.
- 5 Photographic evidence must be provided with any/all warranty claim forms showing the defect/fault (unless the claim is for missing parts that cannot obviously be photographed).

15 Revision Log

Issue Number	Change Implemented	Date
2.1	Hydraulic circuit updated in maintenance section to show proportional tracking block.	16 April 2025

Intentionally Left Blank.



RUBBLECRUSHER

RUBBLECRUSHER HQ
Little Alton Farm, The Altons, Ravenstone, Coalville,
LE672AA
Tel: +44 01530 563600
Email: info@rubblecrusher.com